

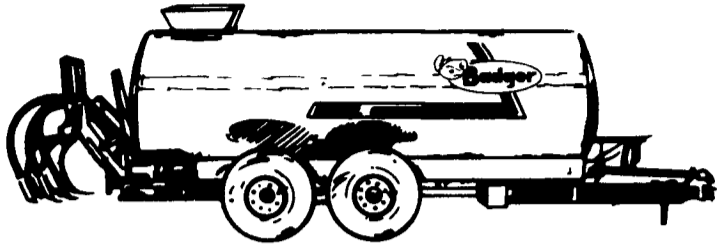

# BADGER TAKES CARE OF ALL TYPES OF MANURE HANDLING NEEDS

**12500L Liquid Manure Spreader Tank Now Built with Cor-Ten Steel**

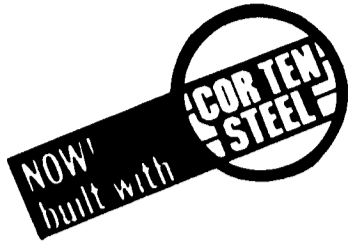

**Better Than 1/4" Mild Carbon Steel**

- 20% stronger
- up to 8 times more corrosion resistant
- 10% lighter in weight
- retains its "new" look much longer
- 10-year limited warranty

**BADGER LIQUID MANURE TANKS WAIVER OF FINANCE TIL APRIL 1, 1988**

- Or**
- 0% For 12 Months
  - 6.9% For 24 Months
  - 8.9% For 36 Months
- LOW RATE FINANCING**

# Badger

## Parts and Service

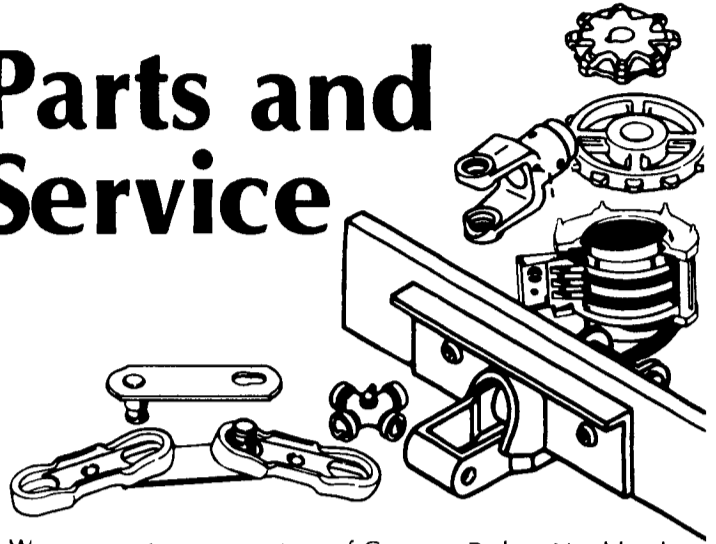

We carry a strong inventory of Genuine Badger Northland replacement parts. We sell Badger equipment and it is our policy to be in a position to service what we sell... fast. You can depend on Badger products and you can depend on us to provide Badger-Quality Service. Remember, genuine Badger Parts are designed for Badger Equipment. Your equipment will perform better with Badger.

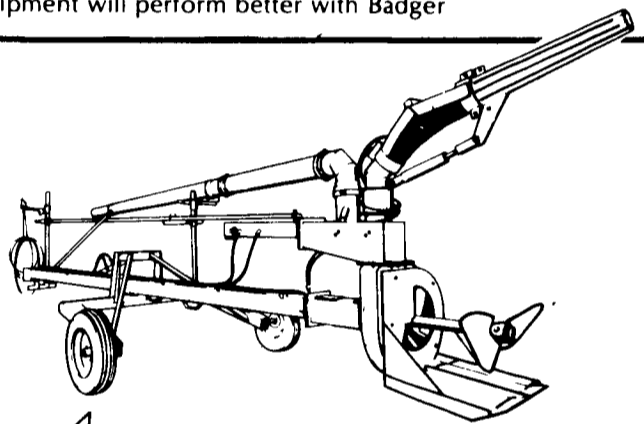

## Badger BN185 Souper Trail Pump/Agitator

- Up to 26,000 GPM agitation capacity
- Standard 28 foot length extendable to 38 feet for really big lagoons
- Choice of cutter blade or propeller options to match biggest agitation needs
- Exclusive internal shear bar chops even straw-laden manure
- Semi-cupped impeller paddles for high capacity pumping

**BADGER SPREADERS & FORAGE BOXES WAIVER OF FINANCE TIL APRIL 1, 1988**

- Or**
- 0% For 12 Months
  - 5.9% For 24 Months
  - 8.9% For 36 Months
- LOW RATE FINANCING**

# Badger



## High Capacity MANURE AUGER

For handling wet, sloppy manure.

- 15" diameter heavy wall PVC pipe won't rust or corrode
- Heavy-duty drive frame with double reduction drive for extra strength
- High capacity 13 1/4" auger
- Designed for minimum maintenance, long service-free life

### CALL YOUR LOCAL DEALER FOR ALL YOUR EQUIPMENT NEEDS

<b>*BHM FARM EQUIP. INC.</b> RR 1 Annville, PA 17003 PH (717) 867-2211	<b>PIKEVILLE EQUIPMENT INC.</b> RT 2 Oley, PA 19547 PH (215) 987-6277	<b>WILLIAMS FARM SYSTEMS</b> RR 1, Box 324 Linden, PA 17744 PH (717) 398-0829	<b>C. PAUL FORD &amp; SON</b> RT 1 Everett, PA 15537 PH (814) 652-2051	<b>MELVIN G. MILLER</b> RT 2 Spring Mills, PA 16875 PH (814) 422-8279	<b>HEFLIN SALES &amp; SERVICE</b> 12312 Oak Hill Rd Woodsboro, MD 21798 PH (301) 898-3233
<b>*CHIDESTER FARMS</b> RD 2, Box 75 Kingsley, PA 18826 PH: (717) 289-4260	<b>McMILLEN BROS.</b> RR 1 Loysville, PA 17047 PH (717) 789-3961	<b>TROY MOTORS CO.</b> Troy, PA 16947 PH (717) 297-3674	<b>CARYLE GRIMM</b> Bridgewater, VA 22812 PH (703) 828-3626	<b>LEONARD WORK</b> RR 3 Brookville, PA 15825 PH (814) 849-3361	<b>FANCY FURROW FARMS AG EQUIP., INC.</b> RR 1, Uhler Rd Easton, PA 18042 PH (215) 252-8828
<b>RALPH KETTERER</b> Deep Run Box 98 Rt 1 Perkasie, PA 18944 PH (215) 766-8531	<b>SHOW EASE STALL CO.</b> 573 Willow Rd Lancaster, PA 17601 PH (717) 299-2536	<b>HONESDALE SPREADING SERVICE INC.</b> 505 Cliff St Honesdale, PA 18431 PH (717) 253-2410	<b>HESS' EQUIPMENT</b> Sales & Service RR 3, Mifflinburg, PA 17844 PH (717) 966-2720 966-1998	<b>WOLFE'S BADGER SALES</b> RR 1 Box 420 Milton, PA 17847 PH (717) 524-0931	<b>CECIL DAIRY STORE</b> RR 1 Rt 274 1/2 Mi South Rising Sun, MD 21911 PH (301) 658-6923

\*NEW DEALERS