

RUBBER MATTING AND USED BELTING

• COMFORT STALLS • FREE STALLS
• HORSE STALLS • CATTLE & HORSE
• HOG PENS & HOUSES TRAILERS
All Sizes Available & Custom Cut
Phone 301-885-5045

ATTENTION BUY OUT FARMERS

We Need Good Used Tanks
500 - 6,000 Gal. - Call Us

USED BULK TANKS

All Tanks Guaranteed A-1 Working Condition

• 600 & 700 Gal. Mueller "M's"

- 400 Gal. Sunset
- 400 Gal. Girton
- 500 Gal. Milkeeper
- 500 Gal. Girton D-4
- 500 Gal. Girton
- 500 Gal. Mueller
- 600 Gal. Jamesway
- 600 Gal. Jamesway
- (2) 600 Gal. Milkeepers (Round)
- 600 Gal. Girton D-4
- 625 Gal. Sunset
- (2) 735 Gal. Sunsets
- 800 Gal. Girton D4
- 800 Gal. Mojonnier
- 800 Gal. Van Veeter
- 800 Gal. Zero
- 800 Gal. Mueller "OH"
- 800 Gal. Dari Kool
- 1000 Gal. Dari-Kool
- 1000 Gal. Sunset
- 1000 Gal. DeLaval
- 1000 Gal. Milkeeper
- 1200 Zero (No Leaker)
- 1500 Gal. Mueller "OH"
- 2000 Gal. Mueller
- 2500 Gal. DeLaval
- 4000 Gal. Girton

• 600 GAL. 31" POURING HEIGHT VERY NICE
400, 500, 600 & 800 Gal. (Storage Tanks)

• Used 3 & 5 H.P. Electric Motors

USED COMPRESSORS

3 H.P., 4 H.P., 5 H.P. — R12 & R22

24 Hrs. - 7 Days A Week - Refrigeration Service

Installation, Sales And Service

RAY SHENK

505 E. Woods Drive Lutz, PA 17543

Sales 717-626-1151

24 Hr. Service 717-627-2747

FIND OUT!

Why the most progressive dairymen in the northeast are using the **HEMOCEL 100** Program for herd health and production.
For your nearest dealer contact

agri-dynamics
P.O. Box 318, Martins Creek, PA 18063
(215) 588-8150

BUCKET MILKERS

And Supplies

GREAT PRICES

2 Year Warranty Warranty does not include plastic or rubber parts. Pulsator has only a 1 year warranty.

Westfalia puluator and 65 lb pail
Complete unit price only... \$395
(Also available with DeLaval Super-Flow claw)

DeLaval puluator, 65 lb. pail and Super-Flow Claw
Complete unit price... \$405

65 lb. Buckets only \$155

Easy-to-pour, extra strong handle, full solid rim 2 year warranty. Available for DeLaval, Westfalia, Bou-Matic kds, etc. free shipping or delivery

New Westfalia and Bender Claw Washers.....\$115

New stainless steel 4 or 5 unit Claw Wash Tubs. \$40

Pulsator Repairing, Wash Tubs, Inflatons, Sputnick Parts, Misc.

Free Delivery. Risk-Free Trials. Satisfaction Guaranteed.

See Classified Ads For Listing On Used Equipment.

Notice: We Will Have 5 or 6 Used Sputnicks Available

March 1st. If Interested Contact NOW!

E-ZEE MILKING EQUIPMENT

5215 Peters Rd., Kinzers, PA 17535

(717) 354-4346

Take 340 till Rt. 807. Go 1 mi. Keep left on Peters Rd.

3rd Farm - John B. Zook Farm

Calumet ... Better Than Ever!

See us at the Pennsylvania Farm Show

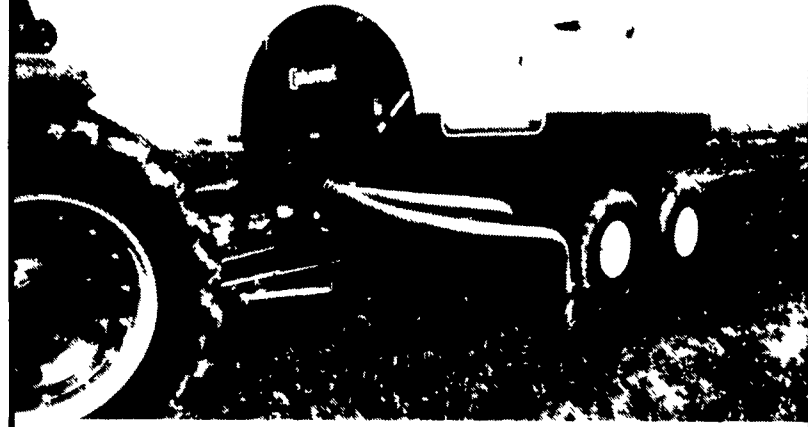

The solid name in liquid manure spreader tanks just got better. Better features, added strength and a better buy.

- Sizes from 2 250 to 3 750 gallons • Stress Proof spindles •
- Heavy Duty undercarriage • Choice of flotation tires •
- Fast, even unloading • Pull type or truck mounted •
- Soil Injectors available •

Calumet builds tanks for experienced farmers. If you're thinking about a new spreader tank talk to your Calumet Distributor about our competitively priced units. All are better than ever - from the solid name in liquid manure equipment

SPECIAL WINTER DISCOUNTS During January & February

F. ERNEST SNOOK

RD 3, Box 84 Mifflinburg, PA 17844

(717) 966-2736

"We're Here To Serve You"



A 1st Class Team Together For 20 Years!



RUFUS BRUBAKER REFRIGERATION & MUELLER Dairy Farm Equipment

OFFER

TWO WAYS TO "PRECOOL" MILK

One With Water

MUELLER ACCU-THERM™ PRECOOLER

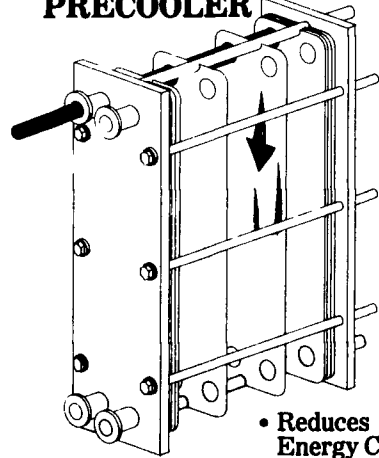

• Reduces Energy Cost

- Flexibility
- Low Maintenance
- Pays For Itself



One With Freon

MUELLER REFRIGERATED RECEIVER



PRE-COOLING DOES MAKE A DIFFERENCE!

Isn't it time for you to join the growing number of dairymen testifying to the improvement the Refrigerated Receiver has made in their operations!

Southern Service Center
468 Dry Wells Rd.
Quarryville, Pa.
717-786-1617
Vic Leininger

MAIN OFFICE
614 Penryn Rd.
Manheim, Pa. 17545
717-665-3525
Ken or Ed Brubaker

Northern Service Center
RD 1, Box 199
Myerstown, Pa.
717-933-4711
Ken Kopp

* 24 Hour Service In S.E. PA, S. Jersey, Delaware N.E. And Eastern Shore Maryland!

* Call Today For All Your New or Used Milk Tank And Refrigeration Equipment Needs!

YOUR HEADQUARTERS FOR NEW AND USED LIQUID MANURE EQUIPMENT

HOWLE WE DELIVER ANYWHERE **UIC**

US AGRI-SYSTEMS
SPECIALIZED FARM EQUIPMENT

OXFORD, PA 19363

(800) 222-2948

(301) 396-2948