

FOR SALE BY OWNERS

MODERN 300 COW DAIRY

EQUIPMENT - FARM EQUIPMENT

FOR PRIVATE SALE - **HECKTOWN DAIRY**

198 NAZARETH PIKE - BETHLEHEM, PA.

For appointment to inspect- Call Manager Tim Robbins - Days (215) 759-5177 or 2883, Eve. (215) 759-7783. Tractors- John Deere's- 2- #4020 DL's, 2- #4010 DL's, Ford #2000 w/HD loader, Cat D4 Crawler Dozer w/Ripper. Equipment- Schwartz #1500 H.D. Front Loader, Little Auggie #LA9C Feeder Wagon Like New, 2- NH #717 Choppers, JD #50 Side Mower, JD Gear, 3 PT Scraper. Milk Equip.- Girton 2000 gal. Bulk Tank. Bou-Matic Double 8 Parlor w/16 Model 2100 Auto take off units- Computor #2025-3" SS low line- 2 D.L. #78 pumps, flush sys- Sells as Complete Unit. 2 Ice Builders, Copelamatic Comp. 2 mos. old, water gun, Heat exchanger, Melco comp., 6 heaters, 1000 gal. Girton Tank. Att.- IHC #2010 Truck w/2000 gal. Milk Tank body & pumps. Manure Equip.- Nesselth Liq. PTO Manure Pump (1 yr. old), De Laval 3500 gal. PTO Liq. Manure Spreader, NH #328 PTO Spreader w/gate, De Laval 110 ft. shuttle barn cleaner (unit 1 yr. old). Cattle Equipment- 350 self supporting HD free stalls, 300 cow mats, 6 fans, 10 Ritchie & 3 AgStar Waterers, 30 to 40 Gates, self-locking feeder stanchions, Head gates, Holding Area Chutes, Etc. Some of above equipment was used in a Va. heifer barn set up! Priced for quick sale! Call for appointment! First Come First Serve Basis!



**NOW AVAILABLE
TANKS IN STAINLESS STEEL
For Sale Or Lease**

- Spreader Tanks - 2250 Thru 6500 Gallons
 - Vacuum Tanks - 1500 Thru 4500 Gallons
 - Earthen Pit Pumps
 - Vertical Shaft Pumps
 - Truck Mount Tanks - 2250 Thru 4500 Gallons
 - Propeller Agitator
 - Replacement Vacuum Pumps - 177 Thru 353 CFM's
- Used Equipment**
- Calumet S3250 Spreader Tank
 - Nesselth 3 pt. Hitch Open Pit Pump
 - Calumet 1600 Gal. Truck Mount Vacuum Tank (Ideal for septic hauling)
 - Calumet 25 Ft. Lagoon Pump

SPREADER TIRE SPECIAL
16.5x16.1, 10 Ply \$145.00 ea.
F.O.B. Mifflinburg

F. ERNEST SNOOK

RD 3, Box 84, Mifflinburg, PA 17844

PH: (717) 966-2736

"WE'RE HERE TO SERVE YOU"

WANTED: 10 used free stalls. Also 10 cow mats. 650 gal. Dari-Kool milk tank, good condition.
215-445-6156 301-797-5503



- Bucket Milkers
 - Vacurex Regulators
 - 6 Nipple Washers
- 1st Quality Service & Sales

LLOYD RANCK
(717) 687-6361

**RUBBER MATTING AND
USED BELTING**

- COMFORT STALLS
- HORSE STALLS
- HOG PENS & HOUSES
- FREE STALLS
- CATTLE & HORSE TRAILERS

All Sizes Available & Custom Cut
Phone 301-885-5045

**EVEN SPREAD GUARANTEED
- WIC LOW PROFILE SPREADER**

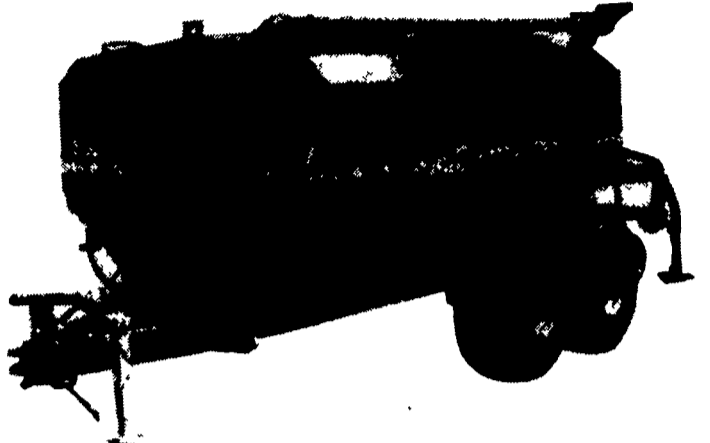

Excellent Rear Visibility For Better Control

CALL TODAY OR WRITE

**US AGRI-
SYSTEMS**

SPECIALIZED FARM EQUIPMENT

OXFORD, PA 19363

(800) 222-2948

(301) 398-2948

Dealer Inquiries Invited



A 1st Class Team
Together For 20 Years!



**RUFUS BRUBAKER REFRIGERATION
&
MUELLER
Dairy Farm Equipment**

OFFER

TWO WAYS TO "PRECOOL" MILK

One With Water

**MUELLER
ACCU-THERM™
PRECOOLER**

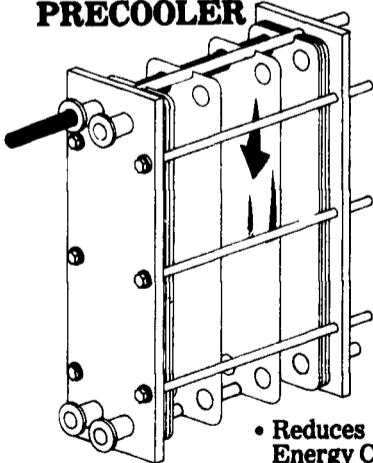

• Reduces Energy Cost

- Flexibility
- Low Maintenance
- Pays For Itself

**MUELLER
Accu-Therm™
PLATE HEAT EXCHANGER**

One With Freon

**MUELLER
REFRIGERATED
RECEIVER**



**PRE-COOLING DOES
MAKE A DIFFERENCE!**

Isn't it time for you to join the growing number of dairymen testifying to the improvement the Refrigerated Receiver has made in their operations!

MAIN OFFICE

614 Penryn Rd.
Manheim, Pa. 17545
717-665-3525
Ken or Ed Brubaker

Northern

Service Center
RD 1, Box 199
Myerstown, Pa.
717-933-4711
Ken Kopp

**take a
closer look!**

**MUELLER
HiPerForm**



- HiPerForm Refrigeration Control
- Mueller Matic Washing System
- Flashing Alarm Light When Milk Is Too Warm or Too Cold
- There's Just No Substitute for a HiPerForm Milk Tank!

USED TANKS

Large Selection Of Good Used Tanks In Stock
All Guaranteed

MARTIN'S REFRIGERATION, INC.

Phone (717) 352-2783
Sales & Service

1122 Woodstock Rd
Fayetteville Pa 17222