

Task Force Focusing On Dry Weather

Responding to mounting concern in the agricultural community over the continued dry spell which is severely affecting some areas of the state, the newly-formed Maryland Agricultural Emergency Task Force was convened for the first time Friday, July 31st at the Maryland Department of Agriculture in Annapolis.

A nucleus group formed in accordance with the Agricultural Emergency Plan submitted to Governor William Donald Schaefer earlier this year by Secretary Wayne A. Cawley, Jr., the task force represents a wide range of agribusiness interests and state and federal agencies, including the Maryland Farm Bureau, Maryland State Grange, Delmarva Poultry Industry, Maryland Department of Agriculture, Soil Conservation Service, Agricultural Stabilization and Conservation Service (ASCS), Farmers Home Administration, the Agricultural Statistics Service, and the Cooperative Extension Service of the University of Maryland.

Governor Schaefer has asked

Secretary Cawley to provide him with a current assessment of statewide conditions and the steps being taken to assist the affected farmers.

An accurate assessment of statewide conditions and interagency coordination are the first goals of this task force. Although current information is sketchy, it was determined that some areas of the state are hard-hit already by drought, while other areas are in relatively better condition. Because of the spotty nature of the drought this year, and the need to know the specific conditions in each county, ASCS is currently carrying out a county-by-county assessment in order to determine the actual extent of drought damage and crop loss in Maryland.

Local extension agents are already very active in providing information and are helping farmers as much as possible by testing silage corn for nitrates and advising on pest control problems made worse by excessive heat, etc.

The task force, designed to be a

support team for the agricultural community and advisory body to the Secretary and the Governor, will submit the loss survey report to Governor William Donald Schaefer immediately upon its completion. The task force also will present any specific recommendations it may have to the Governor.

For further information, contact Anne G. Sieling, Maryland Department of Agriculture at 301/841-5882.



READ LANCASTER FARMING FOR COMPLETE AND UP-TO-DATE MARKET REPORTS

Now is the TIME to think about your garden and lawn equipment, that is, if you want to save MONEY.

25 Tools & Attachments Available



Tuff-bilt



ALLEN H. MATZ, INC.
505 E. Main St., New Holland
Ph: 717-354-2214
SERVING THE COMMUNITY
THIRTY-SEVEN YEARS

LANC. CO'S OLDEST FORD DEALER

**IT'S HERE!
THE ALL-NEW SCN200R
ROOFING COIL NAILER.**

**Special Introductory Prices
While Supplies Last**

We're offering special, too-good-to-miss deals on this all-new, state-of-the-art air-powered roofing coil nailer from Senco®.

- Drives 5 full round-head galvanized roofing nails.
- 50% productivity increase over the hammer.
- Easy, one-hand use... hold shingles with free hand
- No special training...you're productive the first day.
- Pays for itself in 250-300 squares, even less if you already have a compressor.

Stop In Today! Take advantage of these special deals on the new Senco SCN200R Roofing Coil Nailer.

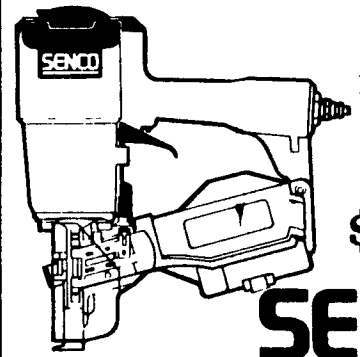

List \$467.00

SALE PRICE

\$350.00

SENCO®
FASTENING SYSTEMS

BLUE BALL MACHINE CO., INC.

INDUSTRIAL EQUIPMENT & SUPPLIES
P.O. Box 369 Blue Ball, PA 17506-0218
(717) 354-4478

Mon., Tues., Wed., Fri 7:30-5:00, Thurs 7:30-9:00, Sat 7:30-11:30

NEW SWINE FACILITIES WANTED

You, Mr. Landowner, Build A New Swine Facility According To Our Specifications... We Will Lease The Facility From You On A Long Term Basis (Must be within 90 mi. radius of Lancaster, PA)

Sow Contracts Available Based On Production.

Finishing Contracts Available Based On Production.

EXCELLENT RETURN GUARANTEED

Call Today

FARM CREST FEEDS

35 N. Cedar St.

Lititz, PA 17543

(717) 626-0331

Ask For Tom Weidman

Your Local Master Mix  Dealer