



# JOHANNING'S

Family Store



# SPRING SALE



2460 New Holland Pike, Lancaster, PA 17602  
 1/4 Mile West of Meadowbrook Farmers Market, Rt. 23, Leola  
 (717) 656-3700 or (717) 291-4420

**SALE MARCH 29 THRU APRIL 11, 1986**

**Hours:**  
 Mon.-Thurs. 8 AM-8 PM;  
 Fri. 8 AM-9 PM  
 Sat. 8 AM-5 PM

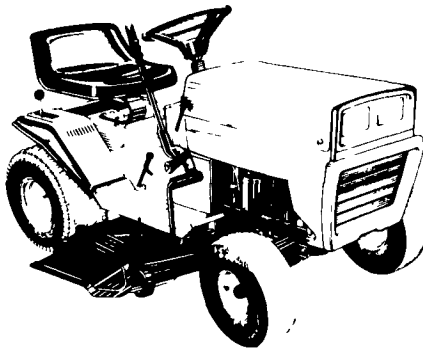

## RANCH KING

11 HP/38" Cut/7-Speed  
 Model 135-668-205

- 15.00"x6.00" tubeless front tires
- 18.00"x9.50" tubeless rear tires
- 11 HP B & S engine, 24.36 cu. in., synchro-balanced
- 12-volt alternator/starter
- Safety interlock system
- 7-speed Transmatic\*
- Two belt driven 19" blades
- 5-position cutting height adjustment
- Headlights and ammeter

Reg. \$1,049.00

**SALE ..... \$949.00**

## THE BIG BOY

500 GALLON  
 MODEL



Step and Stand (Optional)

MODEL DQL500P8A RNA  
 w/FBT12RNA Boom  
 Weight Approx 1130 lbs

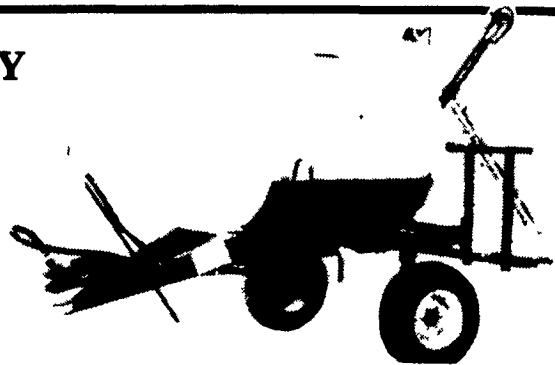

- 500 Gal Sprayer Less Tires & Pump
- 300 Gal Sprayer, Less Tires & Pump
- 55 Gal Sprayer 3 Pt Less Pump
- 25 Gal Lawn Sprayer
- 200 Gal Skid Mount Sprayer w/Pump & Motor
- 110 Gal Skid Mount Sprayer w/Pump & Motor
- 110 Gal Sprayer, 3 Pt w/Pump

	Reg.	SALE
500 Gal Sprayer Less Tires & Pump	\$1,440.00	\$1,360.00
300 Gal Sprayer, Less Tires & Pump	\$1,060.00	\$960.00
55 Gal Sprayer 3 Pt Less Pump	\$414.00	\$375.00
25 Gal Lawn Sprayer	\$499.00	\$459.00
200 Gal Skid Mount Sprayer w/Pump & Motor	\$980.00	\$925.00
110 Gal Skid Mount Sprayer w/Pump & Motor	\$890.00	\$840.00
110 Gal Sprayer, 3 Pt w/Pump	\$760.00	\$708.00

## WIESE MOLDBOARDS

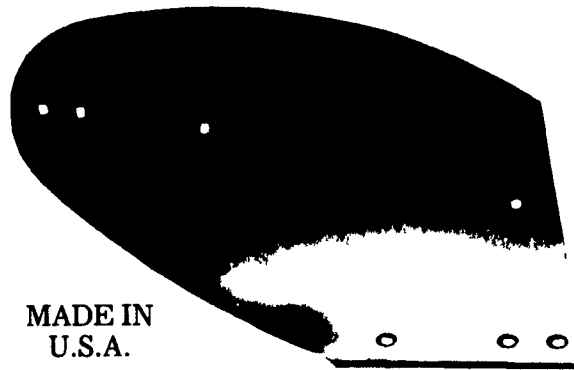

MADE IN U.S.A.

Description	Reg.	SALE
70901 JD 104 8NU.....	\$51.59	\$46.24
70902 OL 619-16 .....	\$40.89	\$36.89
70903 OL 619-14 .....	\$38.59	\$34.89
70903 CA EX16.....	\$41.69	\$36.79
70939 CA EX14.....	\$43.19	\$38.25
70941 FD 104409.....	\$36.19	\$33.29
70942 IH 462314.....	\$40.49	\$36.69
70986 JD H5316.....	\$40.39	\$37.09
70987 JD H5314.....	\$32.69	\$29.89
70988 CA 345966 .....	\$44.69	\$40.89

## ROCK SHARES (RS) SERIES

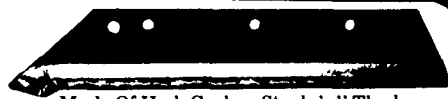

Made Of High Carbon Steel, 1/2" Thick  
 At Center - Heavier Than Most  
 OEM Shares

Description	SKU	Reg.	SALE
MI 16-3	0141	\$9.99	\$7.79
MF 14-4	0142	\$8.59	\$6.99
MF 16-4	0143	\$9.99	\$7.79
IH 14-4	0144	\$9.49	\$6.99
IH 16-4	0145	\$9.49	\$7.79
JD 14-1	0146	\$8.59	\$6.99
JD 16-1	0148	\$9.49	\$7.79
JD 14-4	0149	\$8.59	\$6.99
JD 16-4	0151	\$9.49	\$7.79
JD 18-1	0152	\$10.98	\$8.79
JD 18-4	0153	\$10.98	\$8.79
OM 14-4 Right & Left	0154	\$8.59	\$6.99
OL 16-4	0156	\$9.98	\$7.99
OL 16-5	0157	\$11.19	\$8.99
AA 14-4	70148	\$9.99	\$7.79
AM 16-4	0159	\$9.49	\$7.79
AL 16-4	0161	\$11.19	\$8.99
CA 16-4	70162	\$9.99	\$7.99
FF 14-4	70163	\$8.59	\$6.99
FF 16-4	70164	\$9.49	\$7.79
FF 18-5	70166	\$10.49	\$8.79
MI 14-1	70167	\$8.69	\$6.99

## SICKLE BLADE ASSEMBLIES



Description	Reg.	SALE
70979 NH 451-456, 9 Ft	\$46.69	\$41.99
71257 NH 479-488, 9 Ft	\$58.49	\$53.99
71262 NH 469, 9 Ft	\$64.19	\$59.99
71258 NH 489, 9 Ft	\$75.39	\$69.99
75203 NH 455-450, 7 Ft	\$59.39	\$52.99
71273 JD 47-50-250-350, 7 Ft	\$44.68	\$41.99
71268 Hesston 1090, 9 Ft	\$47.59	\$44.99
71312 IH 1190, 9 Ft	\$58.98	\$54.99
71266 NH 495-1495, 12 Ft	\$85.89	\$79.99

## UNIVERSAL TRACTOR PUMP

Up to 45 gals. per minute. Pressure up to 450 P.S.I.  
 UNMATCHED IN PRESSURE & VOLUME OUTPUT,  
 OPERATION SMOOTHNESS AND TRACTOR MOUNT  
 & MAINTENANCE EASE.



## 8 ROLLER PUMP

76001

- TYPICAL APPLICATIONS**
- Fire Fighting
  - Boom Spraying
  - Stock Jetting
  - Tank Filling & Bottling
  - Pressure Cleaning of Piggeries & Dairies, Trucks, Tractors, Machinery Implements, Farming Plant Facilities, Concrete Floors, Etc., Without The Need Of Detergents Or Solvents

**\$107<sup>19</sup>**

**Dura-Life DOG FOOD**  
 50 Lbs.  
 75015

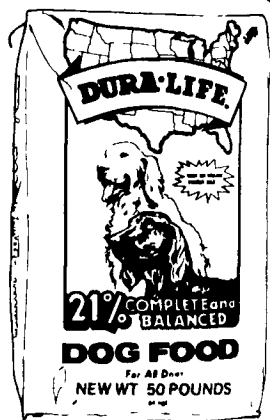

Reg. \$9.49  
**SALE \$6.99**

## EarthWay™

Products

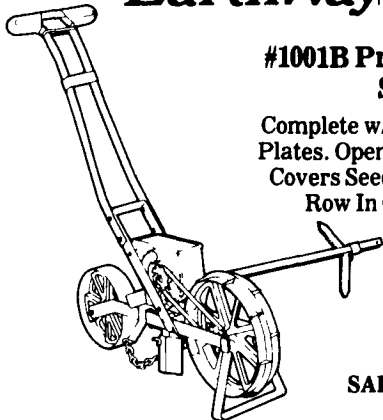

### #1001B Precision Garden Seeder

Complete w/6 Changeable Seed Plates. Opens Soil, Spaces Seed, Covers Seed, And Marks Next Row In One Operation.

Reg. \$48.95  
**SALE \$39.95**



## QUAKER STATE MOTOR OIL

- Super Blend 10W30
- Super Blend 20W40

Your Choice

SALE ..... **89¢** qt.  
 • Deluxe 10W40  
 SALE ..... **99¢** qt.

## 14 CU. FT. HAND CART

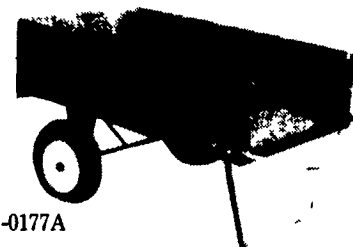

No. 41-0177A

Reg. \$124.95

**SALE... \$109.95**

## K-ARC™ MODEL 100 MIG WELDER

For home or industry - compact & economical

75801

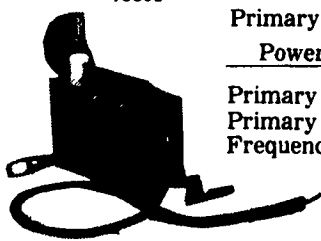

Primary or Input Power Data      Model K-ARC-100

Primary Volts ..... 115 Volts  
 Primary Amps ..... 15 Amps  
 Frequency ..... 60 HZ

**\$325<sup>89</sup>**

## NEW BULK DAIRY PIPELINE AND BULK TANK CLEANERS

- Reinforce Circulation Cleaner And Acid Rinse
- 5 Gals. .... **\$3.40/Gal.**
  - 10 Gals. .... **\$3.30/Gal.**
  - 15 Gals.
  - or More ..... **\$3.20/Gal.**

### Heavy Duty Circlean Chlorinated Circulation Cleaner

- 5 Gals. .... **\$4.40/Gal.**
- 10 Gals. .... **\$4.30/Gal.**
- 15 Gals.
- or More ..... **\$4.20/Gal.**

Bring Your Own Containers