



Pennsylvania Dairy Herd Improvement Association

Lebanon County DHIA Monthly Report

Owner	Brd	Age	No Cows	Days In Milk	Lbs Milk	Lbs Fat
LEBANON COUNTY DHIA						
January, 1986						
Donald G Hoffer	3	44	0	88	8	20 392 762
Willow Maple Farm	3	46	3	91	0	20 969 761
Irvin Z Brubaker	B3	50	4	88	8	20 577 756
Hoover Farms	3	129	9	86	7	20 902 754
Gary Mase	G3	30	4	88	0	20 648 751
David Brandt	3	73	1	88	2	21 549 743
Roy H Weaver	3	53	9	88	9	20 224 738
Arnold Acres	3	111	5	88	3	19 792 728
Ferndale Farms	3	77	2	82	6	18 932 720
Dale Hostetter & Sons	3	98	8	84	3	18 773 718
Marvin K Meyer & Sons	B3	88	7	91	2	19 213 717

Kenneth Mase	B3	95	6	87	3	18 933 709
Fort Zeller Farm	B3	49	7	86	4	19 720 702
Arthur R Krall & Son	3	68	4	85	8	19 306 701
Lloyd Burkholder Jr	B3	53	0	83	4	19 646 699
Gary Lentz	3	71	8	86	9	19 603 696
Roy E Nolt	B3	64	4	84	4	19 305 692
Robert Martin	B3	52	1	89	9	18 350 690
Melvin M Nolt	B3	61	0	85	8	17 484 689
Robert B Smith	2	71	2	85	9	14 089 688
Raymon & Marlin Getz	3	56	6	83	6	18 234 685
Sonnen Springs Farm	B3	51	0	84	7	18 913 683
Kirby L Horst	3	47	9	86	7	17 965 682
Eugene Gingrich	B3	37	0	87	7	18 879 681
M Luther Bennetch	G3	71	9	88	0	18 315 681
David Weaver	B3	41	2	89	1	20 463 679
Mark C Patches	B3	105	0	87	6	17 913 678
Walter K Heisey	B3	58	6	90	4	19 066 678
Wernerway Farms	B3	134	8	87	9	18 975 677
James Z Brubaker	B3	52	6	86	5	20 004 676
Marlin D Heisey	B3	51	3	86	0	19 305 672
Phares Z Musser	3	84	5	86	4	17 531 671
Harvey T Bomgardner	3	97	9	87	1	18 456 670
Sonnen Acres	B3	67	6	86	4	18 469 669
Richard & Ronald Shirk	3	74	1	88	0	18 760 668
Kenneth I Sellers	3	63	7	86	2	17 932 668
Clyde E Deck	B3	67	0	88	4	18 935 664
Reuben O Martin	B3	72	7	85	3	18 021 663
Lester Martin	B3	63	3	88	4	18 133 662
Richard L Heilinger	B8	13	5	87	5	18 158 657
Philhaven Farm	3	96	2	89	0	18 484 651
Raymond K Martin	B3	50	3	87	1	19 002 650
Louis E Martin	B3	43	5	85	6	19 241 650
Robert B Smith	18	2	8	04	305	20 139 49 988
136	2	4	01	305	18 725	5 1 952
Kenneth I Sellers	3	3	10	305	21 043	3 8 807
Heather	3	3	10	305	21 043	3 8 807

Lancaster Farming Saturday, March 8, 1986-D25

Willow Maple Farm	3	4	11	305	28 720	3 2 921
Denise	3	7	02	305	24 293	3 9 952
Ferndale Farms	3	7	02	305	24 293	3 9 952
Myra	3	7	06	305	24 531	4 2 1034
David Brandt	3	2	03	305	25 539	3 5 903
39	3	7	06	305	24 531	4 2 1034
100	3	2	03	305	25 539	3 5 903
Harvey T Bomgardner	3	7	02	305	23 945	3 4 824
Debra	3	7	02	305	23 945	3 4 824
Marvin K Meyer & Sons	3	4	07	305	23 075	3 8 877
Tina	3	4	07	305	23 075	3 8 877
County Line Farm	3	4	06	305	20 146	4 1 827
40 E	3	4	06	305	20 146	4 1 827
Dale Hostetter & Sons	3	3	04	305	22 684	3 7 829
107	3	3	04	305	22 684	3 7 829
6	3	3	05	284	19 520	4 2 820
M Luther Bennetch	3	4	00	305	23 385	3 5 828
Sophie	3	4	00	305	23 385	3 5 828
Richard & Ronald Shirk	3	5	03	305	25 066	3 4 844
Libby	3	5	03	305	25 066	3 4 844
San Bo Holsteins	3	6	04	305	20 825	4 1 859
Hattie	3	6	04	305	20 825	4 1 859
Fort Zeller Farm	3	4	11	288	21 367	4 0 851
Pokey	3	4	11	288	21 367	4 0 851
Sandra	3	4	20	305	22 308	3 7 822
Rhonlyn	3	4	01	305	19 746	4 8 946
Clyde E Deck	3	6	01	305	19 172	4 3 817
2	3	6	01	305	19 172	4 3 817
Mark C Patches	3	5	05	305	21 672	3 9 848
56	3	5	05	305	21 672	3 9 848
Enos N Leinbach	3	6	11	305	21 036	3 9 814
Katrina	3	6	11	305	21 036	3 9 814
Reuben O Martin	3	7	10	305	26 950	3 3 879
Hostess	3	7	10	305	26 950	3 3 879

(Turn to Page D26)

POPULAR BIG DUTCHMAN CAGE SYSTEMS FOR COMMERCIAL EGG PRODUCTION

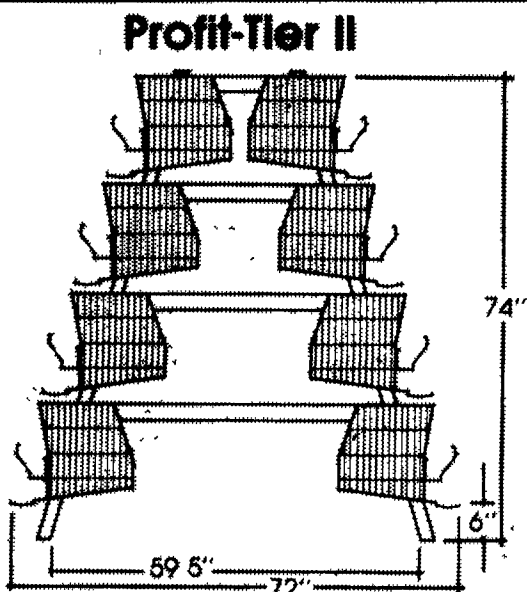

Available in 8-foot or 10-foot cage sections. Cage size options: 12"x14"; 15"x14"; 16"x14" and 24"x14".

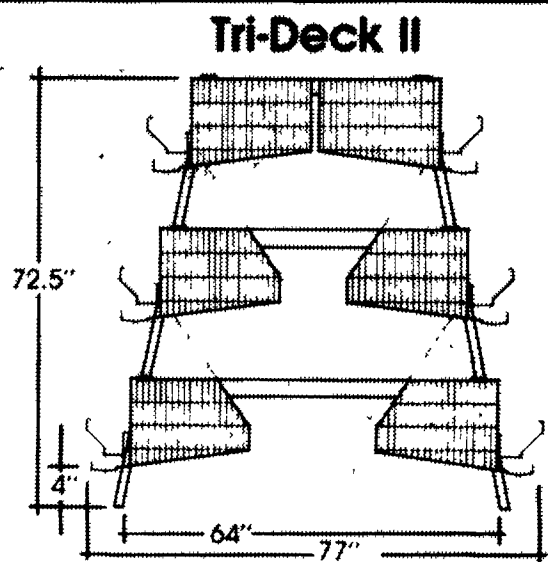

High density in the proven low profile cage design. Available in 8-foot or 10-foot cage sections. Cage size options: 12"x20"; 15"x20"; 16"x20" and 24"x20".

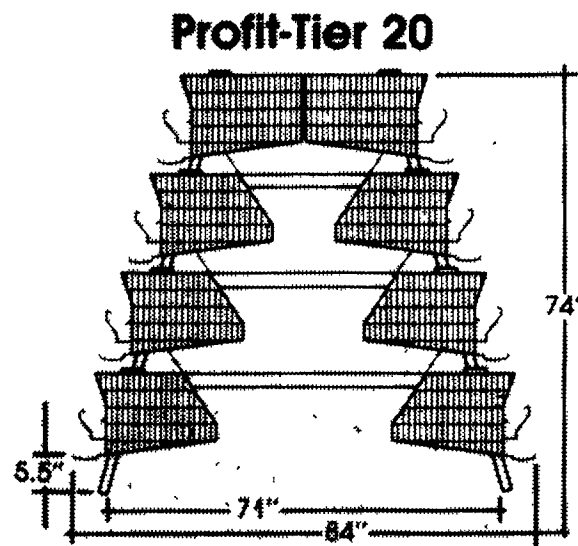

Four tiers of low profile, 20" deep cages on a condensed row width for very high capacity without crowding. Available in 8-foot or 10-foot sections. Cage size options: 12"x20"; 15"x20"; 16"x20" and 24"x20".

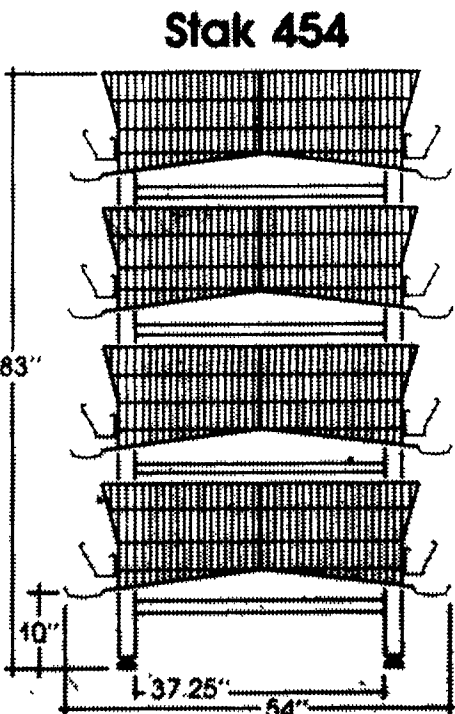

Four tiers, 54-inch width overall, with quiet running belt manure removal. Cages installed in 8-foot sections. Cage size options: 12"x20", 16"x20" and 24"x20".

Big Dutchman.



Big Dutchman offers the important features that make a cage system work better and last longer.



HERSHEY EQUIPMENT COMPANY, INC.

Designers of Quality Systems for Poultry, Swine and Grain Handling

SYCAMORE IND PARK
255 PLANE TREE DRIVE
LANCASTER, PA 17603
(717) 393-5807

Route 30 West
at the
Centerville Exit.

MECHANICAL TRANSPLANTER

ORDER NOW FOR SPRING DELIVERY



- New Amazing "Flo-Check" Water Valve (Patented with Magic Air Control to assure uniform water supply to the plants regardless of water level in barrel.
- New Manual Shutoff with Automatic Roller Reset on Valve.
- Positive Action, Self-Cleaning, Neoprene Plant Grippers • Bronze Oilite Main Bearings
- Large Adjustable Plant Trays

Lancaster County's Only Dealer Specializing In Sprayer Sales & Service

LESTER A. SINGER

96 N. Ronks Rd. Ronks, PA 17572

(717) 687-6712 or 295-2308

Mon. - Fr. 8 to 5; Sat. 8 to 12