



# MESSICK FARM EQUIPMENT, INC.

Farm Equipment Is Our Business  
RHEEMS EXIT, RT. 283, ELIZABETHTOWN, PA.

"The Best Of Two Worlds"

PH: (717) 367-1319 Toll Free In PA. 1-800-222-3373 Warren Spickler-Home 653-4560

We Ship UPS

## CASE IH 684 TRACTOR w/2250 LOADER

Mounting  
and Dismantling  
Was Never  
Easier

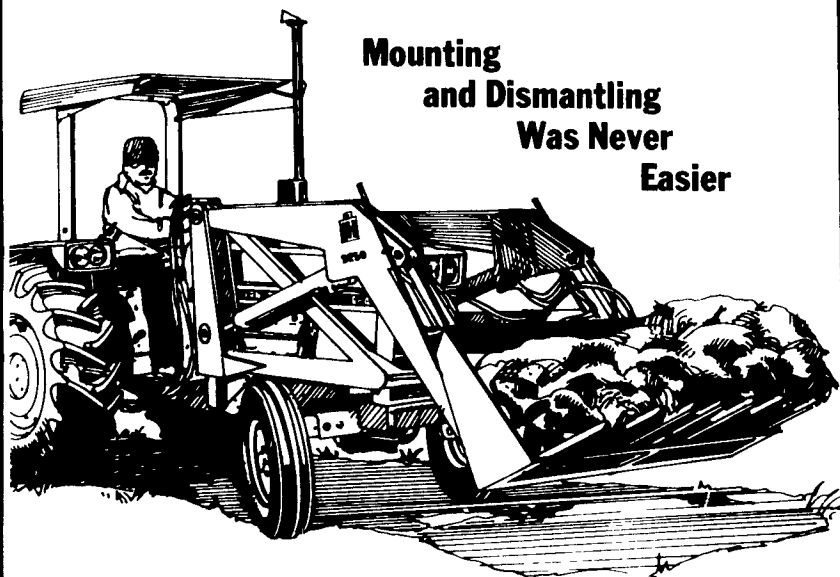

2250 Mount-O-Matic has a 10 ft. dump and is ideal for 40 to 80 horsepower tractors.

Demo Unit - One Only

Call Today!

## GET UP TO 25% MORE GRAIN WITH 6" SEED SPACING

Drill With The Case International "5100 Special"

Outstanding accuracy begins with IH feed cups that deliver seed uniformly. Dual rib press wheels then compact the soil around the seed and gently "pat" the top to prevent air holes. The result is uniform germination and an emergence toward higher yields.

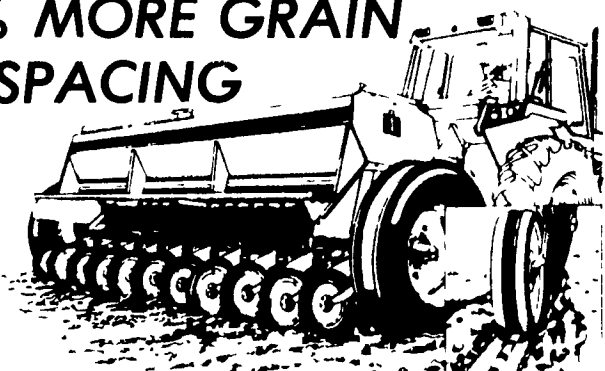

- 60" diameter rotor
- 30.5 inch extendable hopper
- Easy drive-in convenience
- Automatic air inlet
- Direct 540 R.P.M. PTO line
- Wheels adjust for clearance, leveling and height

## CASE IH MODEL 600 FORAGE BLOWER

Capacity to match tall silos

### GOOD CLEAN USED EQUIPMENT

#### TRACTORS

- Ferguson 30 w/Woods Mower
- Farmall 460
- IH 350 Fast Hitch
- IH Farmall Cub w/Mower
- IH 784 Row Crop w/TA
- IH 856 Wide Front 3 Pt

#### PLANTING & SEEDING

- IH 400 Planter w/Liquid Fertilizer 4 Row
- JD 16x7 Grain Drill Disc Openers
- IH 400 Planter 6 Row w/Dry Fert
- IH 13 Disc Drill
- IH 510 Grain Drill 13x7

#### SPREADERS & GRINDER MIXERS

- NI 218 Spreader w/Gate Tandem Axle Nice 10 Ton
- NH 519 Spreader w/Top Beater Gate Splash Guard
- NH 676 Spreader w/Hyd Gate
- NH 512 Single Beater
- NI 214 Spreader /Double Beater, Original Paint On Floor Like New
- NI 218 Spreader w/Tandem Axle, New Web
- NH 790 Spreader w/Hyd Gate
- NH Model 371 Tandem Axle Spreader
- IH 540 w/Pan, Like New

#### TILLAGE

- Oliver 4 Row Cultivator
- IH Model 450 Plow

#### MISCELLANEOUS

- NH 960 Grain Platform 13
- Walsh 300 Gal Trailer Sprayer w/Boom (used 1 time)

#### SKID LOADERS

- NH L225
- NH L775 Diesel w/Backhoe
- Case 1737 w/2 Buckets

#### Used FIELD QUEEN SELF-PROPELLED HARVESTER

Cat. Diesel w/Cab, 3 Row Head & Hay Pickup Head, Good Cond.



#### HAY & FORAGE

- NH 275 Baler w/Thrower
- IH #40 Shredder 4 Row
- NH 2 Row Snapper 30 Rows
- NH 718 Chopper w/Head
- IH 56 Blower
- IH 555 Forage Harvester w/Cornhead & Pickup Attachment
- NH 269 Baler
- JD 24T Baler w/Thrower
- NH 320 Baler w/Thrower (Ex Cond)
- NH 495 12 Ft Haybine Ex Condition
- NH 489 Haybine

- NH 852 Round Baler Auto Tie Excellent
- NH 479 Haybine
- NH 273 Baler w/Thrower
- NH 256 Rake
- Studebaker Truck w/No 8 Forage Wagon
- Hesston Mower Cond 9 Ft Cut Ex Condition
- JD 16A Flail Chopper
- NH 855 Round Baler Auto Tie
- NH 770 Forage Harvester w/2 Row Cornhead & Pickup Attachment
- NH 85 Big Round Bale Automatic Wagon

#### TOP OF THE LINE USED EQUIPMENT

- IH 830 Forage Harvester, 3 Row Cornhead & Pickup Attachment
- NH #8 Forage Box Wagon
- NH 238 Tandem Axle Wagons
- 1 Pr. Dual Wheels & Tires, 18.4x26 6 Ply
- 1 Pr. Dual Wheels & Tires, 31x5 15-x15 8 Ply

ATTENTION FARMERS: If Parts Are Needed After Hours To Keep You Going, Call Jay Gainer, Our Parts Mgr. At Home 653-2238.



## 0% FINANCING FOR 2 YEARS On Hay and Forage Equipment, Spreaders And Grinder Mixers

### NH 782 FORAGE HARVESTER Featuring THE METALERT™

- The exclusive Metalert™ electronic metal detector prevents costly damage to the cutterhead.

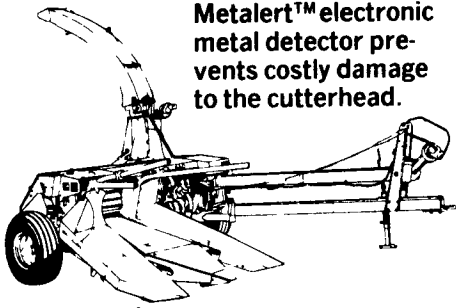

### A NEW GIANT: New Holland 1900 Forage Harvester



5 Year Cutter Head Warranty  
SAVE 40% ON THIS MACHINE  
This Is A Once-In-A-Lifetime Deal!

### NH MODEL 900 FORAGE HARVESTER

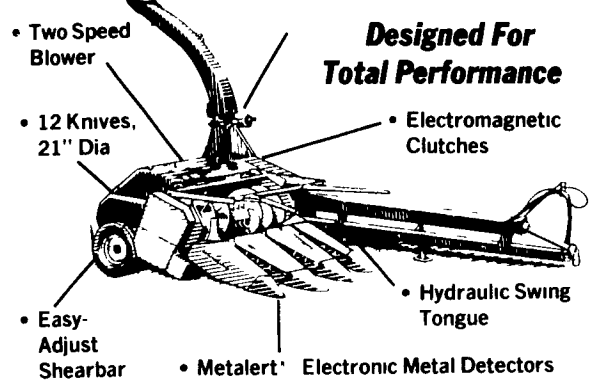

- Two Speed Blower
- 12 Knives, 21" Dia
- Easy-Adjust Shearbar
- Metalert™ Electronic Metal Detectors
- Designed For Total Performance
- Electromagnetic Clutches
- Hydraulic Swing Tongue

### NH 499 MOWER CONDITIONER

One Only Demo Unit



Selling Below Invoice... MUST GO!

### NH MODEL 30 FORAGE BLOWER

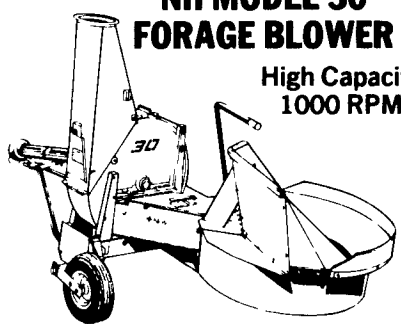

High Capacity 1000 RPM

### NH #8 FORAGE BOX

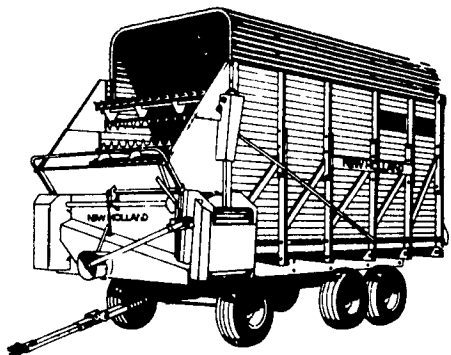

Featuring: 12 Ton w/NH 238 Wagon  
Worm-Gear Drive & Variable Speed For Quick & Easy Unloading



### 0% FINANCING FOR 24 MONTHS

Waiver of Finance On All New Hay & Forage Equipment Till July 1 or Sept. 1, 1986

- OR • Big Cash Rebates
- OR • 0 % Financing - 12 Mos.
- 7.9% Financing - 24 Mos.
- 8.9% Financing - 36 Mos.
- 10.9% Financing - 48 Mos.



## MESSICK FARM EQUIPMENT, INC.

RHEEMS EXIT — RT. 283, ELIZABETHTOWN, PA  
PHONE: 717-367-1319, 653-8867  
TOLL FREE IN PA. 1-800-222-3373  
WARREN SPICKLER — HOME 653-4560

★ WE SHIP UPS

