

SPERRY NEW HOLLAND SQUARE BALERS THE NEW "OLD RELIABLES"

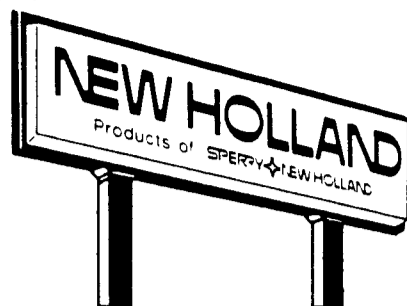

Reliability...

bale after bale

after bale

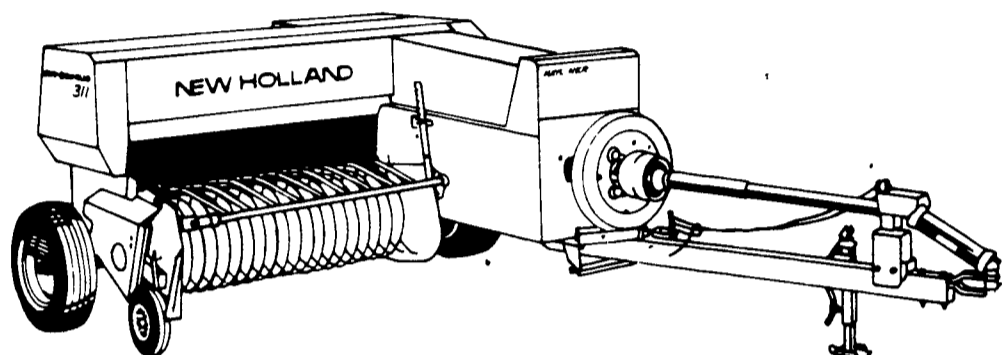

311 Baler

ALL SPERRY NEW HOLLAND 14x18 SQUARE BALERS FEATURE...

- Super-Sweep pickup — gets the short, fine hay ordinary pickups miss.
- Flow-Action® feeding system — high-capacity, uniform bale shape.
- Dependable knotters — go thousands of bales without a miss.
- Choose Your Thrower-Hydraulic Kicker Or Belt Type

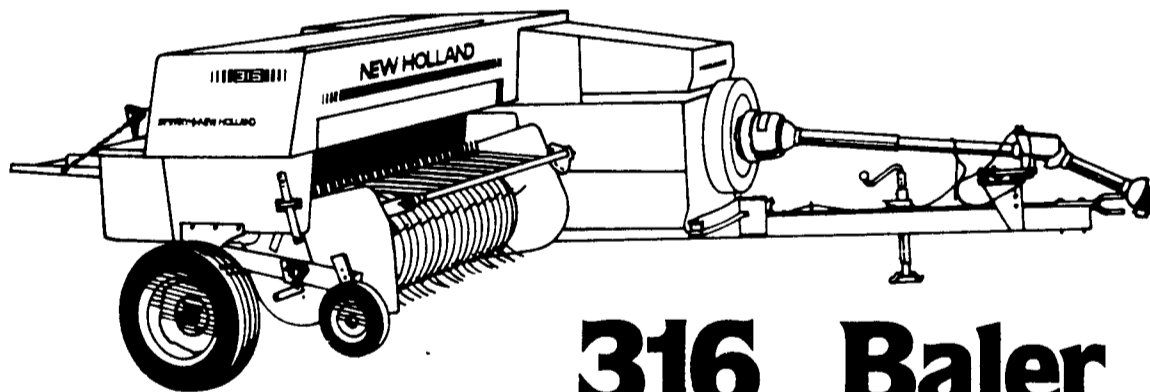

316 Baler

CHOOSE YOUR FINANCE PROGRAM FROM ONE OF THE FOLLOWING...

1. WAIVER OF FINANCE TO SEPTEMBER 1, 1985
- OR -
2. LOW A.P.R.'S FROM 0% TO 11.9% FOR VARYING LENGTHS OF TIME RESPECTIVELY
- OR -
3. SPECIAL DIVIDENDS FOR NOT USING SPERRY NEW HOLLAND FINANCING

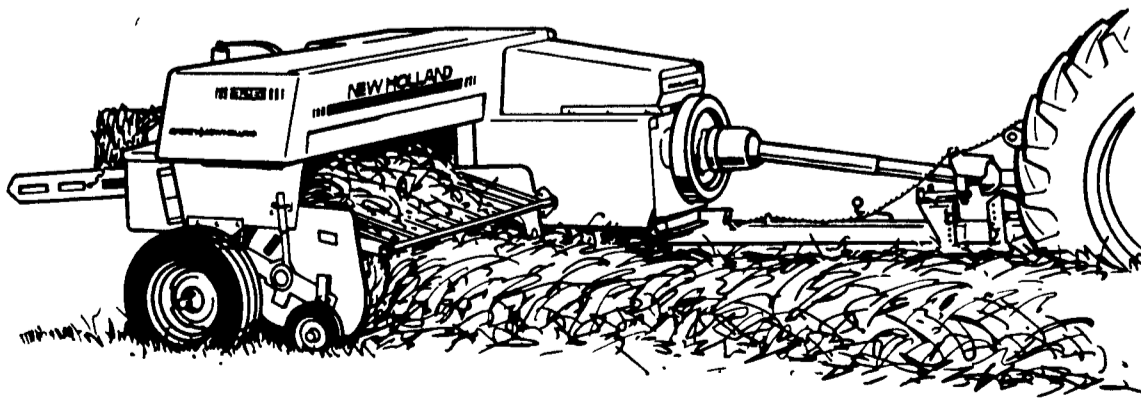

326 Baler