

CENTRAL TRACTOR FARM & FAMILY CENTER



\$32⁹⁹

Reg \$39.99 / SAVE 7.00 3530000 168

OshKosh Insulated Coveralls

Durable press twill coveralls of 65% polyester/35% cotton insulated with 3/3 polyester fiberfill Zipper breast pocket and pencil pocket on sleeve Olive color Sizes 36-50 OshKosh Insul Brown Duck Coveralls

Sizes 40-50 **SALE 41.99**
5040000-168 Reg 47.99



Hurry!

Sale Prices Good Now thru Sat., Nov. 10th

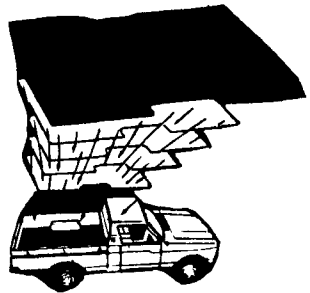

139⁹⁹
Reg 154.99 / SAVE 15.00 16302 084
Industrial Battery Charger
50 amp charge 250 amp boost for 6 & 12 volt batteries. The most economical indoor/outdoor unit available today with 3 year warranty on transformer & rectifier. Coordinated control systems that permit equal programming to charge Maintenance free batteries dry charge batteries lead acid batteries

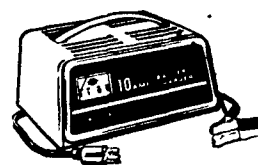

SAVE up to 5**
Battery Chargers

Charges 6 and 12 volt batteries. Rugged steel case accurate numerical dial ammeter shows exact rate of charge

6 Amp
16282-084 **24⁹⁹**
Reg 27.99

10 Amp
16276-084 **28⁹⁹**
Reg 32.99

10 Amp Automatic
16283-084 **36⁹⁹**
Reg 41.99

10-30-50 Amp
Booster Charger **43⁹⁹**
16284-084
Reg 47.99

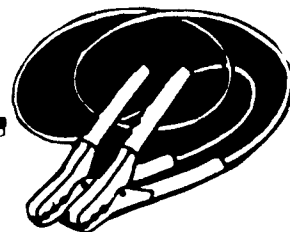

BOOSTER CABLES

8 cable is 10 ga copper, 12' cable is tangle free 8 ga copper. Clamps are 150 amp copper plated steel.

8 Ft. **3⁹⁹**
9581-055 Reg. 4.30

12 Ft. **7⁹⁹**
9580-055 Reg. 8.99

HEAVY DUTY CABLES
Tangle-free copper cables - 12' cable is 6 ga, 16' is 4 ga. Clamps are 400 amp vinyl coated steel!

12 Ft. HD **13⁹⁹**
9610-055 Reg. 15.99

16 Ft. HD **19⁹⁹**
9609-055 Reg. 22.99

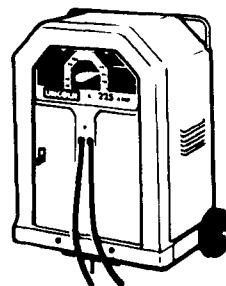

144⁹⁹

Lincoln 225 Amp Arc Welder

Includes ground clamp insulated electrode holder 15 electrode cable 10 ground cable 6 input cable with plug female receptacle and helmet. Uses 220 volt 60 cycle power source. Wheels not included.

Welding Glove 18039 115 **NOW 5.79**
AC/DC Lincoln 225 Amp Arc Welder 18121 115 **NOW 274.99**



159⁹⁹

Reg 169.99 / SAVE 10.00 12997 279

3 Pt. Hitch Log Splitter

Mounts on back of category 1 or 2 tractor in minutes. 6 x 6 steel 1 beam High carbon steel wedge with ground edge and spreader wings handles logs up to 26" long. Less cylinder, valve and hoses. Use with a 3" 3/4 or 4" cylinder depending on tractor PSI. Maximum PSI 25 000

10⁹⁹

Reg 14.99 / SAVE 4.00 28206 311

48" Shop Light Fully Assembled with Bulbs

Comes fully assembled and includes bulbs. Steel construction with white enamel finish. Includes grounded cord and plug chain and hooks for hanging.

48 Replacement Fluorescent Bulb 11351 116 **NOW 2.69**

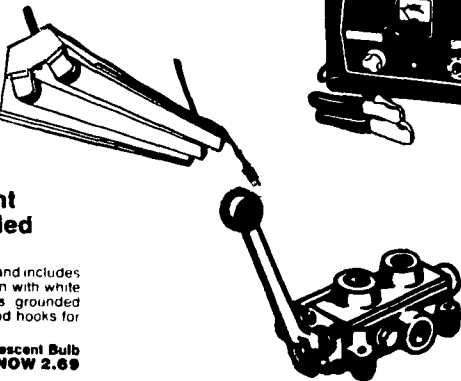

79⁹⁹

Reg 84.50 / SAVE 4.51 28138 310

Hydraulic Control Valve with Detent

Features a pressure released detent with spring return after cylinder reaches 2000 PSI. May be used on double action cylinders on open center systems. 25 GPM and up to 2000 PSI. Inlet and outlet ports are 1/2" and work ports are 1/4"

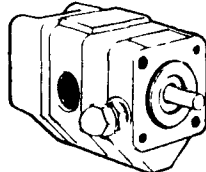

109⁹⁵

4527 008

Hi-Low Hydraulic Gear Pump

Two gear adjustable gear pump for use on log splitters. It may be driven by up to a 2 Hp (1800 RPM) AC electric motor or a 5 Hp (3600 RPM) gasoline engine. 11 GPM @ 3600 RPM

Hydraulic Filter **SALE 12.49**
28165 310 Reg 14.49

4.69

Reg 4.99 / SAVE 6% 27802-285

Chunk Style Dog Food

25 lb bag of 21% chunk style dog food is a complete food supplying all the nutrients necessary to keep your dog in healthy, alert condition. Same formulation as our Golden Choice.

50 lb. Bag **SALE 8.99**
27881-285 Reg 9.79

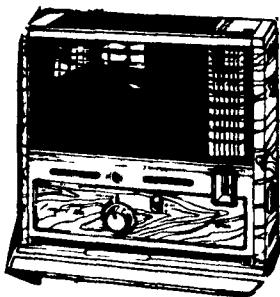
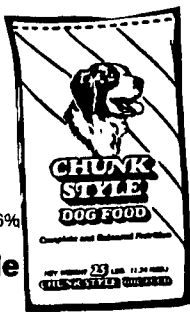

59⁹⁹

Reg 69.99 / SAVE 10.00 24688-260

9,300 BTU Kerosene Heater with Fan

This deluxe model features a built in fan to provide better warm air circulation. elegant woodgrain styling and an efficient glass chimney. It delivers 9300 BTU's warmth and operates for 16 hours on one fueling.

139⁹⁹

Reg 159.99 / SAVE 20.00 24600-260

30,000 BTU Space Heater

Completely portable. Burns kerosene or #1 fuel oil, operates up to 13 hours on a 3 gal tank of fuel. reliable solid state ignition and automatic flame out control.

50,000 BTU Space Heater 24533-260 Reg 189.99 **SALE 169.99**
Thermostat for Space Heaters 23981-260 **NOW 35.99**

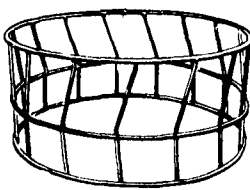

99⁹⁹

Reg 109.99 / SAVE 10.00 18005 253

Galvanized Bale Feeder

2 Piece galvanized 1" slant bars and horizontal frame constructed of 1" galvanized tubing



39⁹⁹

Reg 44.97 / SAVE 4.98

Pass-Thru Rear Cab Window

Curved top frame for "OEM" fit. Anodized aluminum frames. Metal Center lock. Clear out applications include most popular makes & models.



Hydraulic Cylinders

Up to 2500 psi

3"x 16" **79⁹⁹**
6503 017 Reg 84.99

3"x 24" **84⁹⁹**
6504 017 Reg 89.99

4"x 16" **109⁹⁹**
6592 017 Reg 119.99

3 1/2" x 16" **79⁹⁹**
6587 017 Reg 84.99

3 1/2" x 24" **99⁹⁹**
6588 017 Reg 99.99

4" x 24" **129⁹⁹**
66076 017 Reg 134.99

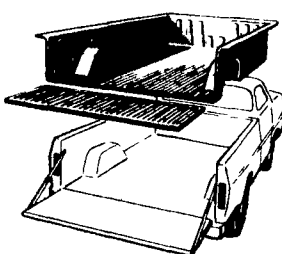

199⁹⁹

Truckbed & Tailgate Liner

One piece rugged truckbed liner. saves wear & tear on your pickup. Resistant to gas oil acids & salts. withstands extreme impacts to 60°F. Tailgate cover included.

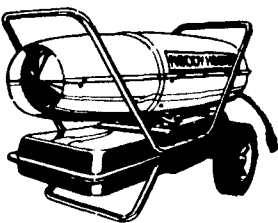

259⁹⁹

Reg 279.99 / SAVE 20.00 23985 260

97,000 BTU Space Heater

Completely portable. Burns kerosene or #1 fuel oil. consumes less than 1 gal per hour. 8 gallon tank. spark plug ignition and automatic flame out control.

150,000 BTU **SALE 339.99**
24001 260 Reg 359.99
Thermostat for Space Heaters 23981 260 **NOW 35.99**



3.29

Reg 3.50 / SAVE 8% 18284-234

1 Gal. 4S Brand Anti-Freeze

Same formulation as famous name brands. Will mix with all ethylene glycol base products. Protects against winter freeze-ups and helps prevent summer boil-overs. Guards your engine against rust and corrosion.

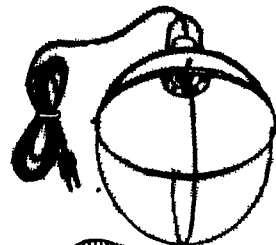

4.99

Reg 5.49 / SAVE 9% 9588 055

Hanging Brooder Lamp

Hanging reflector complete with porcelain high heat socket and wire guard for the bulb. Complete with 6' 18 gauge wire and plug. UL approved.

Clear Bulbs **SALE 1.89**
11432-133 Reg 1.88
Infra Red Bulbs **SALE 3.99**
11433-133 Reg 4.79



109⁹⁹

Reg 119.99 / SAVE 10.00 18012 253

10 Ft. Bunk Feeder

The wide base provides this feeder with stability to prevent cattle from overturning it and wasting feed. The trough area is covered with high density polyethylene plastic. The polyethylene plastic has the advantages of staying flexible in subzero temperatures, never rusting, rotting or needing paint.

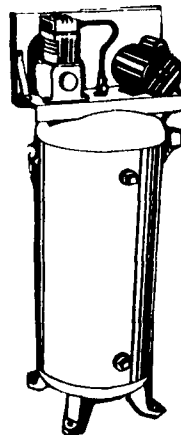

SANBORN AIR COMPRESSORS

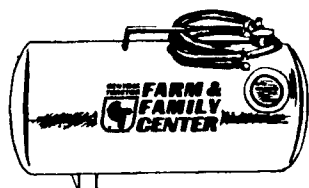

29⁹⁹

Reg 36.99 / SAVE 7.00 17784 106

Heavy Duty Air Tank

Big 10 gallon capacity tested to 200 lbs. Comes complete with 6 foot air hose, chuck gauge and safety valve. Reg. price may vary locally.

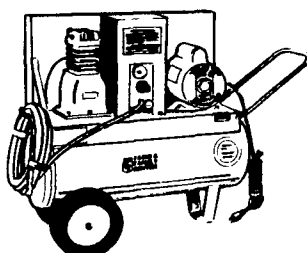

209⁹⁵

Reg 224.95 / SAVE 15.00 17981-106

3/4 Horsepower Air Compressor

10 gallon tank, 4.4 CFM displ. 2.9 CFM at 40 psi. Dial-O-Matic control with easy to read gauge enables you to dial the pressure desired-no additional regulator needed.

15' Air Hose 17791 106 **NOW 5.99**
25' Air Hose 18400 106 **NOW 9.29**
50' Air Hose 18417 106 **NOW 15.99**

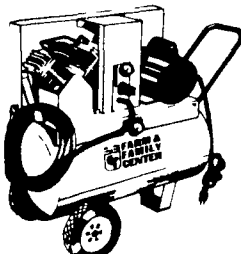

299⁹⁵

Reg 329.95 / SAVE 30.00 18326 106

1 Hp. Twin Cylinder Air Compressor

14 gallon tank, 5.2 CFM at 90 psi. 6.3 CFM at 40 psi. The V-2 Twin cylinders deliver air power. Easy to read gauge enables you to dial the pressure desired no additional regulator needed.

15 Air Hose 17791 106 **NOW 5.99**
25 Air Hose 18400 106 **NOW 9.29**
50' Air Hose 18417 106 **NOW 15.99**

699⁹⁵

Reg 749.95 / SAVE 50.00 18397-106

5 Hp. Air Compressor

Highly efficient medium-duty industrial air compressor with cast-iron twin cylinder 1 stage pump, 5 Hp 230 V single phase electric motor 151 cfm displacement. Features a 60 gal. tank totally enclosed belt guard for safe operation, bleeder type pressure switch for loadless starting.

SANBORN AIR COMPRESSORS

THESE PRICES WILL BE HONORED ONLY AT THE FOUR STORES LISTED BELOW.

FARM & FAMILY CENTER

CHAMBERSBURG
1351 Lincoln Way East Ph 717/264-8282
Open 9-6 Mon - Thur / 9-9 Fri / 9-5 Sat

LANCASTER
1570 Manheim Pike Ph 717/569-0111
Open 8:30-5:30 Mon - Fri / 8:30-5 Sat

QUAKERTOWN
Quakertown Plaza Shopping Center
Rts 309 & 313 Ph 215/538-2494
9-6 Mon-Wed / 9-9 Th & Fri / 9-5 Sat / 12-5 Sun

FLEETWOOD
WEAVER'S HARDWARE CO
RD 4125 Fleetwood PA 19522
(on main road from Fleetwood to Topton)
PH 215 944 7486 - 215 944 9648
Hours Mon thru Fri 8 AM to 7 PM
Sat 8 AM to 4 PM

All items are subject to stock on hand. We reserve the right to limit quantities. Sale ends on above date.

Not Responsible For Printing Errors