

FARM EQUIPMENT

FARM EQUIPMENT

FARM EQUIPMENT

FARM EQUIPMENT

FARM EQUIPMENT

FARM EQUIPMENT

FARM EQUIPMENT

MESSICK FARM EQUIPMENT, INC.

Farm Equipment Is Our Business
RHEEMS EXIT, RT. 283, ELIZABETHTOWN, PA.

PH: (717) 367-1319 Toll Free In PA. 1-800-222-3373 Warren Spickler-Home 653-4560 We Ship UPS

THE NEW NUMBER
1

INTERNATIONAL

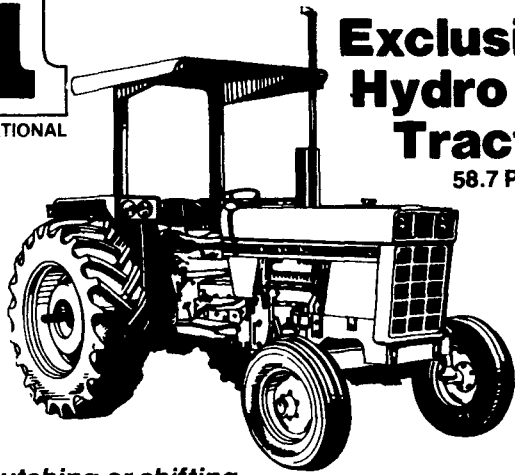

Go power!

Exclusive Hydro 84 Tractor

58.7 PTO hp*

No clutching or shifting

GET UP TO 25% MORE BEANS AND GRAIN WITH 6" SEED SPACING

Drill With The International "5100 Special"

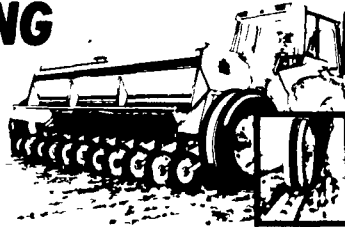

Outstanding accuracy begins with IH feed cups that deliver seed uniformly. Dual rib press wheels then compact the soil around the seed and gently "pat" the top to prevent air holes. Result uniform germination and emergence a start toward higher yields.

IH MODEL 600 FORAGE BLOWER
Capacity to match tall silos

• 30.5 inch extendable hopper for

easy drive-in convenience

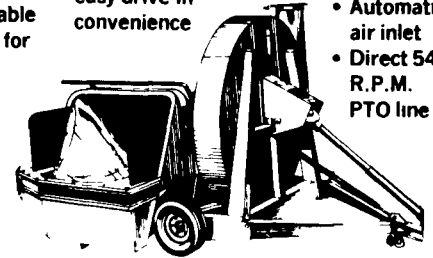

• 60" diameter rotor
• Automatic air inlet
• Direct 540 R.P.M. PTO line

• Wheels adjust for clearance, leveling and height

A GOOD SELECTION OF USED EQUIPMENT



AC Gleaner K, 10' platform, 3R narrow cornhead, excellent cond.

HAY & FORAGE

- IH 56 Blower, HD PTO
- AC Model K Combine w/Platform & 3 Row Corn Head, Ex Cond
- NH 892 Harvester w/919 N3 Corn Head
- JD 14T Baler
- NH 479 Haybine
- NH 1469 Haybine
- NI 5 Reel Rake
- Int 35 Hyd Drive Hay Rake & Tedder Combination
- IH 650 Harvester w/Pickup & Corn Head

- (2) Dion Forage Box Wagons
- IH 1190 Mower Conditioner
- NH 495 12 ft Haybine 1 Yr Old Like New
- NH 2 Row Snapper Head
- Gehl 600 Harvester 2 Row & Pickup
- New Idea 1 Row Corn Picker (Nice)
- NH 880 Harvester w/2 Row Corn Head
- NH #8 Forage Box & 234 Wagon
- HD Big Bale Mover

- IH 60 Shredder 6 Row
- IH 50 Shredder 4 Row
- Owatonna 540 Stack Wagon Excellent Used less than 100 Loads
- Owatonna Stack Mower Excellent Used less than 100 Loads
- IH 990 Mower Conditioner
- IH 225 SP Mower Conditioner
- NH 822 Corn Head

MISCELLANEOUS

- Grain-O-Vator Grain Cart
- Pequea Hay Tedder 9 ft Demo
- Little Giant 40 ft Elevator
- Herd Fertilizer Spreader & Seeder
- NH 352 Grinder Mixer

TRACTORS

- IH 84 Hydro, 1400 hrs like new
- IH 340 Tractor, Fast Hitch
- IH 5088, 136 HP 300 hrs
- IH Cub Lo Boy

TILLAGE

- JD 350 6 Bottom Plow
- IH 440 Plow 4 Bottom 16' Demo
- IH 700 4 Bottom Auto Reset Plow
- Brillion 14 Ft Transport Harrow
- Glencoe 9 Shank Soil Saver w/New Disc
- Brillion 10 Ft Culti Packer
- IH 350 Disk Harrow, 12 ft Nice
- JD 10 ft Rotary Hoe

PLANTERS

- IH 400 Planter 6 or 4 Row
- White 4 Row Air Planter

SPREADERS

- NI 214 3 Beater Spreader
- NH 519 Spreader 2 Beaters Hyd Gate
- NH 516 Spreader
- NH 362 Tank Spreader

SKID LOADERS

- NH L425, Rental Unit
- NH L775 Diesel, Deutz 50 HP



Messick's Invites You To

"COME ON IN... THE WEATHER'S GREAT!"

AND PRICES ARE RIGHT ON NEW HOLLAND HAY EQUIPMENT



A NEW GIANT: New Holland 1900 Forage Harvester

LOOKING FOR A GOOD DEAL...

Example:

NH 495 12 FT. HAYBINE

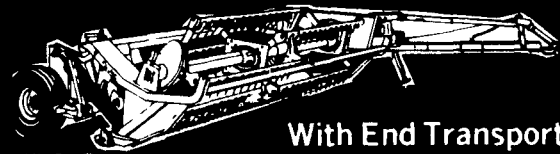

LESS THAN

With End Transport

\$8,900.00

NH 1495 HAYBINE MOWER/CONDITIONER Diesel Hydro

12' cut w/9' conditioning rolls for faster Drying Action

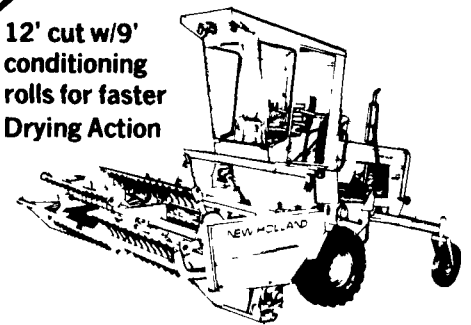

NH 855 ROUND BALER Auto Wrap

The Capacity Champ that turns out solid, well-shaped bales weighing up to 1700 lbs.

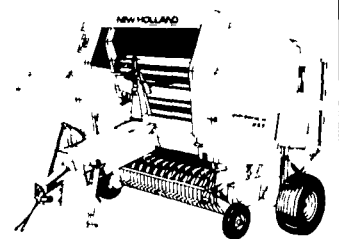

Big Capacity

NH 892 FORAGE HARVESTER

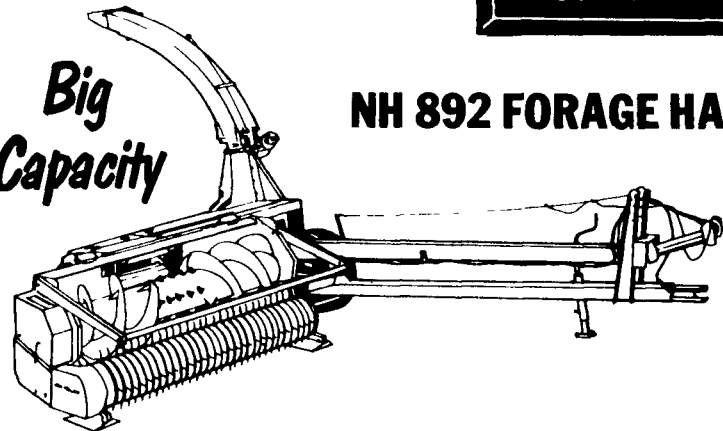

- Metalert-Metal Detector
- 12 Underbeveled Knives Requiring Less HP
- Flip-Up Feed Rolls
- 2 or 3 Row Crop Heads
- Wide Windrow Pickup
- Heavy PTO Shaft

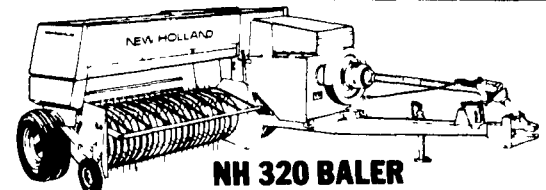

NH 320 BALER

14"x18" Baler designed and built for the big-volume hay grower and custom operator.

NEW PROGRAM:

WAIVER OF FINANCE on Hay & Forage Equipment
Till September 1, 1984

OR LOW RATE FINANCING on New & Used Equipment

- 3% Financing for 1 Yr.
- 6% Financing for 18 Mos.
- 9% Financing for 24 Mos.

OR BIG CASH REBATES



MESSICK FARM EQUIPMENT, INC.

RHEEMS EXIT — RT. 283, ELIZABETHTOWN, PA
PHONE: 717-367-1319, 653-8867
TOLL FREE IN PA. 1-800-222-3373
WARREN SPICKLER — HOME 653-4560

★ WE SHIP UPS