

Safe bicycling

(Continued from Page B14)

riding on the sidewalks.

While obeying the rules can keep you out of many accidents, the cyclist should be aware of other hazards that beginning cyclists often miss. In a booklet titled "Bike Basics" AAA provides a list of those hazards. The list includes:

- Drain or sewer gratings that consist of parallel bars just far enough apart to catch a wheel of a bicycle, forcing it to an abrupt and violent stop. When riding, watch well ahead in your path of travel and never ride over such traps.
- Potholes, bumps, rocks, ice patches, oil slicks, mud, cans, bottles, loose gravel, leaves, or soft shoulders that can cause a fall.
- Water on wheel runs or brake pads that can more than double stopping time for bicycles with handbrakes. When riding in the rain, apply light brake pressure for a short distance to dry out the brakes and recover braking power.
- Sun that can impair your ability to see the roadway. On sunny days wear a good pair of

sunglasses to protect your eyes from glare.

- Car doors opening into the roadway or cars pulling out into traffic, pedestrians crossing the street or children darting out from between parked cars can cause accidents. Beware of these dangers.

- Dogs that like to chase bicycles and snap at the wheels or the rider. A persistent dog can be discouraged by a harmless stream of commercial dog repellent consisting of mineral oil and chili papper.

- Drivers in right-turning cars who may not always see you when you are on their right side. Try not to ride in the motorist's blind area and be prepared for right-turning motorists at all times.

By teaching young children to operate their bicycles more safely, Weik said she hopes that "as they get older, they'll respect bicycling a lot better."

In a few years, she reminded, the kids who are riding bikes today will be driving cars. Learning safe bicycle use today, she said, is an excellent guide for them as they become drivers.

A bicycling 4-H project is

Vegetable recipe contest scheduled for Ag Progress Days

UNIVERSITY PARK — If you have been successful in experimenting with fresh Pennsylvania produce, plan to share your results. Enter your favorite recipe in the fifth annual Pennsylvania Vegetable Recipe Contest. Entries are due by July 20 and final judging will be held August 22 during Penn State's Ag Progress Days at Rock Springs, just west of State College.

Any original vegetable recipe using Pennsylvania grown vegetables in any form as a main ingredient may be entered. All Pennsylvanians 18 years or older, without professional food status, are invited to enter.

The first prize winner will receive \$100, the runner-up will

receive \$50, and the third and fourth place contestants will each receive \$25. All entries will be screened by a panel of judges and the top 12 entrants will be chosen to take their completed dish, prepared as on the entry, to Ag Progress Days on August 22. Facilities for reheating vegetable dishes will be available. Finalists are responsible for their own expenses.

The vegetable dishes will be judged on the following basis: taste and nutrition, 40 points; ease of preparation and practicality, 20 points; originality, 20 points; and appearance, 20 points.

Recipes should feature fresh Pennsylvania grown produce and be specific as to ingredients and instructions. Brand names may not be used. The number of servings and the baking time and temperature, if any, should be clearly stated.

The winning vegetable recipes will be featured in materials used

to promote the vegetable industry in Pennsylvania. The contest is sponsored by the Penn State College of Agriculture, the Pennsylvania Vegetable Growers Association and the Pennsylvania Department of Agriculture.

Each contestant should submit three typed copies of one recipe, complete with entrant's name and address, and telephone number, to: Vegetable Recipe Contest, 401 Agricultural Administration Building, University Park, PA 16802. Entry deadline is July 20.



available for youth who are interested in furthering their bicycling skills. For more information about a club in your area, contact your county's ag extension office.

"I LOST 170 POUNDS"

In about 6 months, and I am still losing. Nothing ever worked for me like the All Natural Herbal Weight Loss Program does I feel great!"

You Lose 10-20 Lbs. Excess Weight In The First 30 Days With The \$29.95 Herbal Slim-Line Kit or your money back.

GO NATURAL

Natural Organic **HERBAL** Products For A Better **LIFE**

- Digestive Problems?
- Sinus Problems & Allergies?
- High Blood Pressure?
- Need To Gain Weight?
- Got Inches & Cellulite?
- Skin Care Problems?

(We Have A PH Balanced Program)



GO NATURAL ON HERBAL PRODUCTS!

Herbal Slim-Line Kit
\$29.95
(Delivered To Your Door)
Plus \$2.75 Delivery Charge

DISTRIBUTORS WANTED!
UNDER \$32.00 TO START
Includes Dist. Kit with Products,
Manual And Sales Helps

JOHN OR GINNY FULLER (J & G FOODS)
93 W. Main St., Leola, Pa. 17540 - Phone 1-717-656-6408
Located on Rt. 23 - 6 Mi. E. of Lanc., same bldg. as Leola Fireplace

Top of the line.

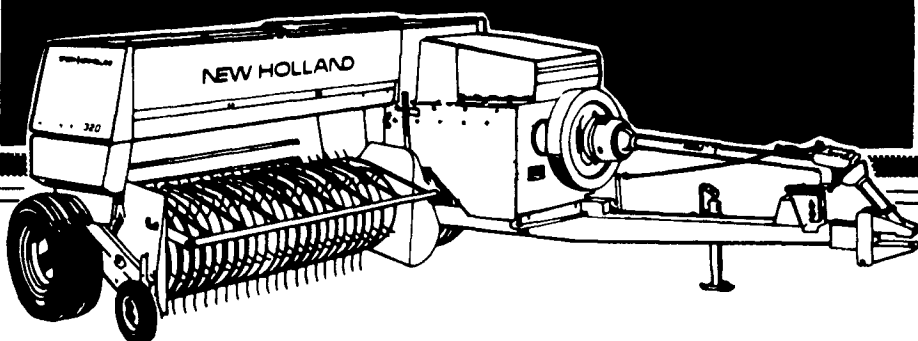

The Model 320 is a 14" x 18" baler designed and built for the big-volume hay grower and custom operator who makes many thousands of bales each season. It makes ideal bales for mechanical bale handling. The famous Super-Sweep pickup is 75 inches wide and is offset to let today's wider tractors drive beside the windrow, not on it. And improved heavy-duty knotters and twisters give trouble-free baling. The bigger the job, the happier you'll be with a Sperry New Holland baler. See the capacity of the Model 320 for yourself.



STOP BY FOR A JUNE DAIRY SPECIAL

PARTS ★ SALES ★ SERVICE



SINCE **TRACTOR CO.** 1921

717-949-6501

NEW TOLL FREE NO. 1-800-822-2152

Rt. 419 Between Schaefferstown & Cornwall, Lebanon County

WE CAN SOLVE YOUR BUILDING PROBLEMS



Roofing & Siding rolled by McElroy Metal Mill (Weatherstrong Aluminum Max Rib Steel)

Red Rose buildings are designed by licensed professional engineers to provide you with maximum useable space. Our buildings are also your assurance of maintenance-free dependability - year after year - because Red Rose Building Systems means the best in materials and workmanship. Get in touch with the area's leading farm and commercial builder.

CALL COLLECT (717) 738-4248 Please contact me with Additional Information

Name _____ LF
Address _____
Town _____ County _____ State _____
Zip _____ Phone (Area Code) _____

Mail to RED ROSE BUILDING SYSTEMS INC P.O. Box 56 Ephrata PA 17522

