

Everyone can help farmland preservation

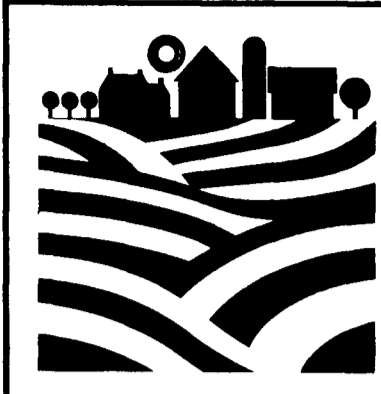

SAVE LANCASTER COUNTY FARMLAND

LANCASTER — Everyone, including farmers and non-farmers alike, can help make a contribution toward the promotion of farmland preservation in Lancaster County.

The Lancaster County Agricultural Preserve Board is

selling bumper stickers calling for the Saving of Lancaster County Farmland.

One to seven copies of the stickers are available at \$1.00 each, plus 35 cents for postage and handling. Seven to 12 copies cost \$1.00 each, plus 55 cents for

postage and handling. Twelve copies or more are available at 85 cents each, plus \$1.00 for postage and handling.

All proceeds will go toward a proposed Agricultural Land Preservation Fund to be utilized exclusively for farm preservation

deed restrictions. The Board is also accepting tax deductible contributions for the same fund.

The bumper stickers can be ordered from the Lancaster County Agricultural Preserve Board, 50 North Duke Street, P.O. Box 3480, Lancaster, Pa. 17603.

Checks should be made payable to the Lancaster County Agricultural Land Preservation Fund.

The bumper stickers feature use of the first-place farmland preservation logo selected by the Board in recent competition.

MID-WINTER SAVINGS DURING FEBRUARY ONLY

**ON ALL
NEW HOLLAND SPREADERS
IN STOCK**

Introducing
a new
"clean
machine".

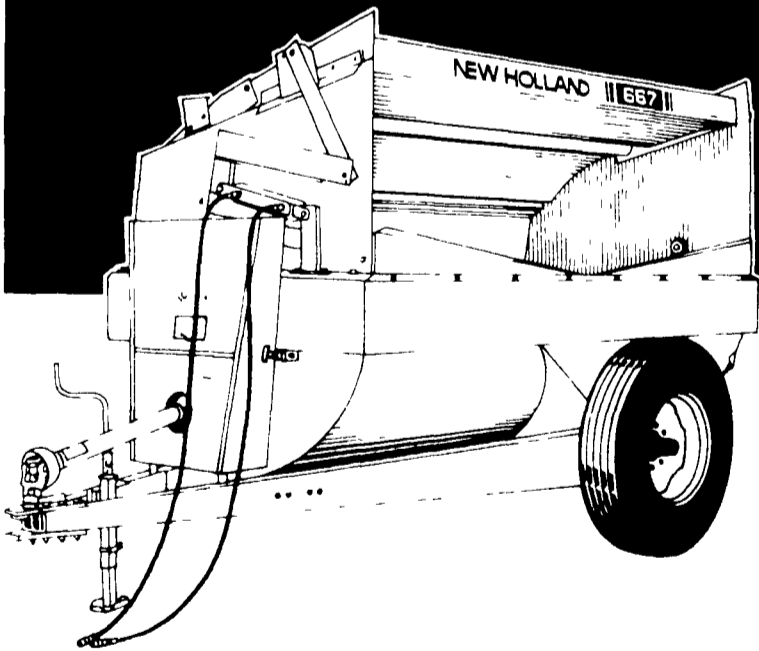

Three new models are available in capacities from 745 gallons to 1,060 gallons. Right- or left-hand unloading is available on all three. And hydraulic foldback lids are standard equipment; you operate them from the tractor seat. Tanks and lids are made from acid-resisting copper-bearing steel so they last longer. Sturdy A frames carry the load instead of pulling it. And rugged flails handle all kinds of manure — even pen-packed slabs or frozen chunks. Come in and look at our new line of "clean machines."

10 tons
per load.

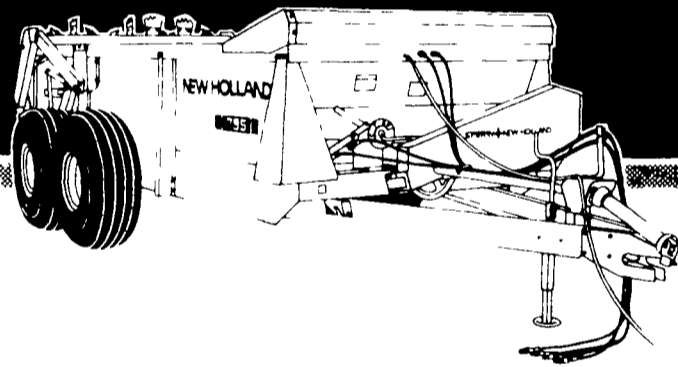

The Model 795 is our second-largest spreader and has an ASAE rating of 440 cubic feet heaped volume (410 bushels). Stop by and take a closer look at the newest addition to the number one selling spreader line in North America. You'll see it has the ruggedness, reliability, performance and convenience features you want in a spreader this size.

**WE HAVE THE SIZE YOU NEED IN STOCK
AND READY TO GO**

513 BOX SPREADER

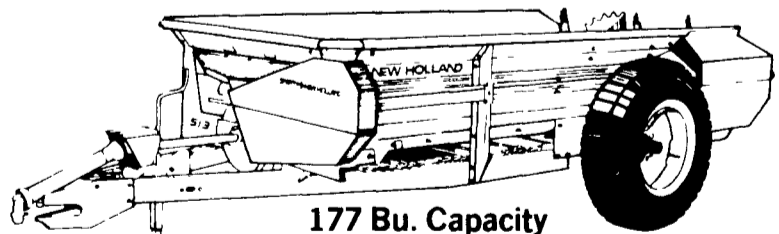

177 Bu. Capacity
• 2 Spreading Speeds & Cleanout

**FOR THE BEST IN MANURE
HANDLING EQUIPMENT, CALL
OR STOP BY KELLER BROS. TODAY**

KELLER BROS.

SINCE **TRACTOR CO.** 1921

717-949-6501

NEW TOLL FREE NO. 1-800-822-2152

Rt. 419 Between Schaefferstown & Cornwall, Lebanon County



Coming...

OPEN HOUSE

Thursday & Friday,
March 8th & 9th, 1984

Watch For Details

AUTHORIZED
SPERRY-NEW HOLLAND
PARTS and SERVICE

