

# MESSICK'S

Farm Equipment Is Our Business

1953-1983  
30th Anniversary

## TEST DRIVE THE NEW INTERNATIONAL SERIES 88 TRACTOR

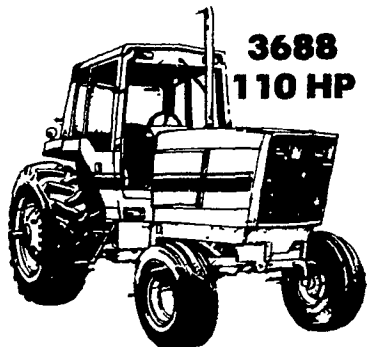

3688  
110 HP

Farmers  
#1  
Choice

## IH MODEL 600 FORAGE BLOWER

Capacity to match tall silos

- 30.5 inch extendable hopper for easy drive-in convenience

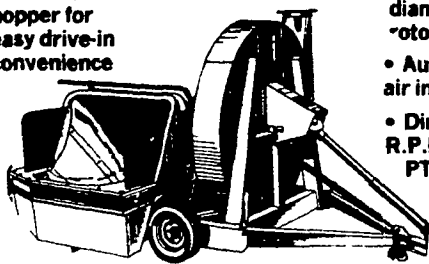

- 60" diameter rotor
- Automatic air inlet
- Direct 540 R.P.M. PTO line

- Wheels adjust for clearance, leveling and height

## GET UP TO 25% MORE GRAIN AND BEANS!

### Drill With The International "5100 Special"

Outstanding accuracy begins with IH feed cups that deliver seed uniformly. Dual rib press wheels then compact the soil around the seed and gently "pat" the top to prevent air holes. Result uniform germination and emergence a start toward higher yields.

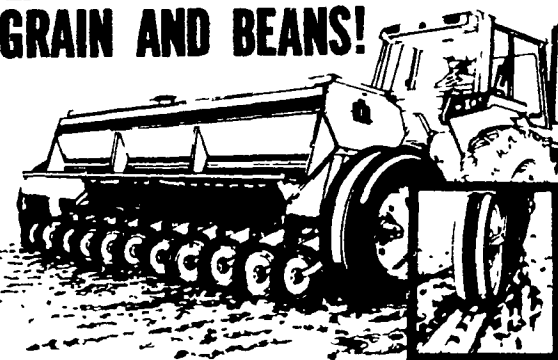

The Key To Faster Emergence Is This IH Dual Rib Press Wheel

## HAY IN A BIG WAY!

NEW FOR 1983

Handles Tough Jobs with Ease

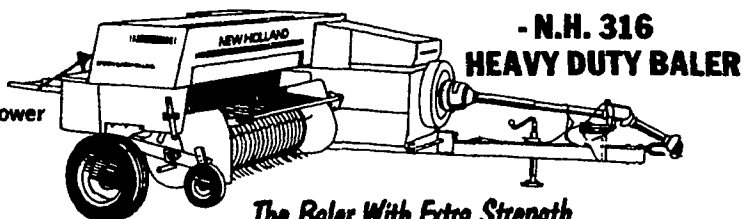

Match a 70 or 75 Thrower w/the 316 Baler

- N.H. 316 HEAVY DUTY BALER

The Baler With Extra Strength And Big Capacity

NH 782 FORAGE HARVESTER

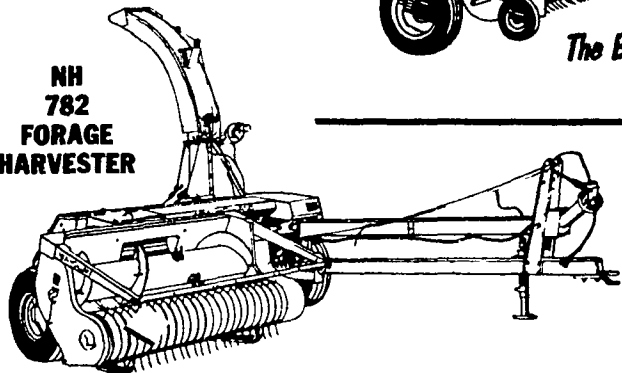

### THE HEAVY DUTY MODEL 782

- 12-Knife Cutterhead chops uniformly.
- Exclusive Underbeveled Knives.
- Flip-up Feedroll makes shearbar adjustment easy.
- Choice of 540- or 1,000- rpm driveline.

### MESSICK'S ANNOUNCES A NEW PROGRAM ON NEW AND USED EQUIPMENT

1. Waiver of Finance to April 1, 1984 with Interim Payment or ...
2. 3%, 6%, 9% APR for 12, 24, 36 Months Respectively.

FLASH

### GOOD USED HAY EQUIPMENT

- Used N.H. 1495 S.P. Haybine w/12 Ft. Rolareel Header, Ex. Condition
- NH 320 Baler w/Thrower
- NH 718 Harvester 2 Row Narrow Corn Head And Pickup
- NH 30 Blower, 1000 RPM
- IH 56 Blower, H.D., P.T.O.
- Hesston 110 Self Propelled Haybine
- NH 852 Round Baler, Auto. Tie, Baled only 300 Bales
- IH 15 Hay Rake
- NH 495 Haybine, 12' Rolareel End w/Transport, Ex. Condition
- MF 9 ft. Mower Conditioner
- NH 36 Crop Chopper
- NH 275 Baler Super Sweep (Good)

### A GOOD SELECTION OF USED EQUIPMENT

#### TRACTORS

IH 1086 w/cab (excellent)  
JD 40 w/Cultivators, 3 Pt. Hitch

#### SKID STEER LOADERS

NH L425 Skid Loader

#### HAY & FORAGE EQUIPMENT

IH 430 Baler w/Thrower  
NH 770 Pickup Attachment  
NH 268 Baler & Thrower  
Gehl Model CB 600 Forage Harvester 2 Row Corn Head & Pickup Attachment, Ex. Condition

#### PLANTERS

IH 400, 6 Row, Monitor, Fert. Attach., Insecticides, Fully Equipped  
IH 56, 4 Row, Fert.  
Int. 56, 2 Row

#### MISCELLANEOUS

JD 3 Section Rotary Hoe, Only \$395

#### TILLAGE

Glencoe 13 shank Chisel  
JD 350 6 bottom auto reset Plow  
Brillion 10 Ft Packer  
White 4 Bottom, 16" Plow  
Krause Model 1580 Single Wing Fold Disc Harrow  
IH Model 55 9 Shank Chisel Plow, Demo  
IH 53 4 Row Cultivator

#### SPREADERS

NH 362 Tank, Good Clean Spreader  
IH 3 Beater 160 Spreader.  
NH 365 Tank Spreader  
NH 518 2 Beater, Excellent  
NH 367 Tank Spreader (Excellent), Hyd. Lid Opener, 1 yr. old

**STIHL**  
The World's Largest Selling Chain Saw

# MESSICK FARM EQUIPMENT, INC.

RHEEMS EXIT - RT. 283, ELIZABETHTOWN, PA  
PHONE: 717-367-1319, 653-8867

WARREN SPICKLER — HOME 653-4560

★ WE SHIP UPS

FARM EQUIPMENT

FARM EQUIPMENT

FARM EQUIPMENT



# BROOKS

FORD TRACTOR, INC.

## SPRING SPECIALS

Ford 7710 w/cab 700 hours  
Ford 10 shank chisel plow

\$19,900  
\$2,450

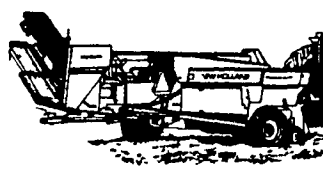

## NEW HOLLAND SPECIALS

PENN STATE ONE YEAR LEASE RETURNS

451 mower \$1750  
38 crop chopper 4200  
1495 mower conditioner 15,000

OTHER NEW SPECIALS

315 baler w/thrower \$8500  
303 liquid injector 1800  
782 harvester w/heads 13000  
489 mower conditioner 7500  
488 mower conditioner 6300

## GOOD USED EQUIPMENT

Mower Conditioner ..... JD 800  
Blower ..... Gehl  
Forage Harvester ..... NH 707  
Tank Spreader ..... Hawk Bilt  
Tank Spreader ..... JD

Box Spreader ..... IH  
Box Spreader ..... JD  
Baler ..... NH269  
Baler ..... NH69  
Hay Rake ..... NH258

West College Avenue  
Pleasant Gap, PA 16823  
PH: 814-359-2751

## Tired of Being Overcharged? THE BATTERY WAREHOUSE

offers a complete line of factory fresh top quality batteries for all of your farming needs at everyday low low prices.

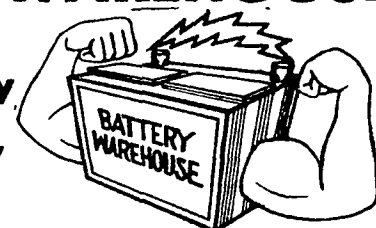

Now Featuring Our Group 1 6 volt At

**\$29<sup>95</sup>** Exch.

440 Cold Cranking Amps  
3 Yr. Standard Warranty

(Our Most Pop. 6 Volt Fits Many Old Farm Tractors)  
We Specialize In "Hard To Find" Industrial Batteries

Passenger Car Batteries As Low As

**\$29<sup>95</sup>** Exch.

FOR MORE INFORMATION - STOP IN OR CALL ONE OF OUR MANY CONVENIENT LOCATIONS

# THE BATTERY WAREHOUSE

6100 Allentown Blvd.  
on Rt. 22 East  
Harrisburg, Pa. 17112  
(717) 652-0565 or 0566

1115A Maugans Ave.  
Hagerstown, Md. 21740  
(Immed. of I-81 - Maugans Ave. Exit)  
(301) 791-7780 or 7781

- 110 Lundy Lane  
Geistown Clover Leaf  
Johnstown, Pa. 15904  
(814) 266-7807

5240 Simpson Ferry Rd.  
Windsor Park Shopping Center  
Mechanicsburg, Pa. 17055  
(717) 697-4414 or 4415

2300 Shillington Rd.  
Sinking Springs, PA 19608  
(215) 777-5284

1519 Mt. Rose  
York, PA 17403  
(717) 846-5925

3108 Pleasant Valley Blvd.  
(Next to Dunkin Donuts)  
Altoona, Pa. 16601  
(814) 942-2888 or 2914

837A Balt. Blvd. Rt. 140  
Westminster, Md.  
From Baltimore  
(301) 876-7188  
From Westminster  
(301) 857-4566

Complete Price Sheet Available Upon Request