

Now is the Time

(Continued from Page A10)

quality cautions Chester D. Hughes, extension livestock agent.

To Check Water Supplies

Water is one of our most important resources, but it should be checked periodically. Many families depend on wells for their water supply. But they pay little attention to the water unless the pump fails or the well runs dry. Your water should be tested periodically to determine its quality.

It is important to test water following any reconstruction or addition to the water supply or its distribution system. Then the system should be checked once a year for continued safety. Water supplies should be checked whenever a disease occurs that

may have been caused by unsafe drinking water. If water changes in taste, odor or appearance for no apparent reason, it should be tested. There are many tests and analyses that can be used. Two of the most important tests for well water are nitrates and bacteria.

Dairy conference

(Continued from Page A1)

George Brumbaugh, chairman of the Pennsylvania Milk Marketing Board, speaking on the present status of the Milk Security Fund, said the Fund has two problems it must overcome. First it must be decided what the goal of the Fund is. Secondly, how it is funded needs to be decided.

Another highlight of the conference was a report on a pilot project for protein pricing being conducted by DairyLea. Don Race, gave the details of the co-op's program that will pay producers a 13 cent premium for high quality milk meeting special protein requirements.

Other highlights included: presentations that echoed the growing concern among sanitarians about water quality; reports on tests being developed to more rapidly detect antibiotic residues in milk; and discussions on Congressional deliberation of dairy legislation.

Highlights of the Conference will be detailed in next week's Dairy Issue. Look for more insight on the predictions made by these 40 dairy specialists next week.



Omaha Cattle

Thursday, May 26

Report supplied by USDA

Compared to previous week's close slaughter steers and heifers ended this week 50-1.00 lower.

Most ingredients for a lower market were presented this week; (lower beef market-increased F.I.S. rates and terminal receipts) but packer demand for immediate slaughter strong enough to hold losses to a minimum. Overall finish ran very similar to the past several weeks, IE. A top layer of attractive cattle balanced by continuing shipments of lighter, weather-stressed stock. Some steers in the latter category sold on a firm note to feeder interests at midweek, most falling into the 1000-1100 lb. bracket.

STEERS: Comprised 49 pct of the week's receipts; heifers 38 pct; cows pct; feeders 6 pct. Four day receipts 12264, week ago 9552, last year 11710.

STEERS: Four loads Choice some Prime 2-4 1200-1250 lbs. 68.75. Scattered loads and part loads Choice 2-4 1050-1275 lbs. 67.00-68.50. Two loads Mixed Good and Choice 2-3 1330 lb. Holsteins 59.75.

HEIFERS: Scattered loads and part loads Choice 2-4 950-1075 lbs. 65.00-66.00, load and part load 66.25. Mixed Good and Choice 2-3 900-1025 lbs. 62.50-65.00. Good 59.00-62.50.

Average of LS 214, detailed quotations for 900-1100 lb. Choice steers 67.40; 1100-1300 lbs. 68.18. Average cost steers 67.25; average weight 1150 lbs.; as compared 67.40 and 1155 lbs. a week ago. Average cost heifers 64.68 average weight 992 lbs.; as compared 64.62 and 994 lbs. a week ago.

COWS: High cutter, Utility and Commercial 1-3 40.00-43.00, high dressing to 45.00. Canner and Cutter 35.00-40.00, "shells" to 27.00.

BULLS: 1-2 1100-1800 lbs. 48.00-53.00.

ROPE IN SOME EXTRA CASH!

Advertise With A Lancaster Farming CLASSIFIED AD...

Phone: 717-394-3047 or 717-626-1164



GRASSHOPPER

THE MOWER THAT MAKES OTHER MOWERS OBSOLETE



1. ELIMINATES HAND TRIMMING (Because your mower deck is out front)
2. HAS ZERO TURNING RADIUS
3. ALL HYDROSTATIC DRIVEN
4. MOWER P.T.O. SHAFT DRIVEN

Purchase A 12 H.P. GRASSHOPPER For Only \$2950 (Plus setup & delivery)

AND GET A 44" MOWER DECK AT 1/2 PRICE

OFFER GOOD ON 12 H.P. MODEL ONLY

Other Models Up To 18 H.P. Including NEW DIESEL

Available At Any Of The Following DEALERS

PENNSYLVANIA

BERKS CO.
ERB & HENRY EQUIPMENT
22-26 Henry Ave
New Berlinville, Pa 19545
(215) 367-2169

JOHN'S MOWER SERVICE
Box 115 R.D. #1
Bernville, Pa 19506
(215) 488-1944

MERTZ LANDSCAPING
R.D. #1 Box 521
Kutztown, Pa 19530
(215) 683-6260

CHESTER CO.

LORD'S EQUIP.
R.D. #3 Box 212
Elverson, Pa 19520
(215) 286-9101

CUMBERLAND CO.

PETERMAN FARM EQUIP.
225 York Rd.
Carlisle, Pa 17013
(717) 249-5338

DAUPHIN CO.

JIM'S LAWN MOWER SERVICE
631 N. Mountain Rd
Harrisburg, Pa. 17112
(717) 545-5114

LANCASTER CO.

LAWN CARE OF PA.
Box 25
Marbndak, Pa 17549
(215) 445-4541

R.S. HOLLINGER
113 W. Main St
Mountville, Pa 17554
(717) 285-4538

SHOTZBERGER'S MACHINERY
Elm, Pa 17521
(717) 665-2141

LEBANON CO.

HEISEY FARM EQUIPMENT
RD#1 Box 2294
Jonestown, PA 17038
(717) 865-4526

LEHIGH CO.

KERMIT N. KISTLER
99 Kings Hwy
Lynnport, Pa 18066
(215) 298-2011

UNION CO.

BENDER'S SALES & SERVICE
R.D. #2
Mifflinburg, Pa 17844
(717) 966-1173

YORK CO.

STRALEY FARM SUPPLY
1760 Canal Road
Dover, Pa 17315
(717) 292-2631

DELAWARE

NEW CASTLE CO.

KEENER & SENSENIG
707 S. Market St.
Wilmington, Del 19801
(302) 655-2790

MYER'S LAWN & GARDEN
R.D. #1 Box 100
Middletown, Del 19709
(302) 378-2849

MARYLAND

BALTIMORE CO.

MIRIE LYNER
14923 Hanover Rd
Upperco, Md 21155
(301) 833-2700

CECIL CO.

DELMAR EQUIPMENT
1752 Appleton Rd.
Elkton, Md 21921
(301) 398-4343

If there is no dealer in your area
Call LAWN CARE DISTRIBUTOR'S
(215) 445-4542

A FANTASTIC OFFER

FROM

FARMER BOY AG, INC.

The New Distributor For

DIAMOND INTERNATIONAL SYSTEMS

Farmington, Michigan

SPECIAL DISCOUNT

ON

DIAMOND 809 TRI-DECK SLANT BACK LAYER CAGE SYSTEM

SPECIAL FEATURES:

- Manure Curtain in Place of Scraper Boards
- Flat Chain Feeding Systems
- Choice of Cup or Nipple Watering Systems
- Choice of Cap Sizes - 4 to 9 Bird
- New Style Egg Collectors (Eliminating Foam Rubber Collectors)

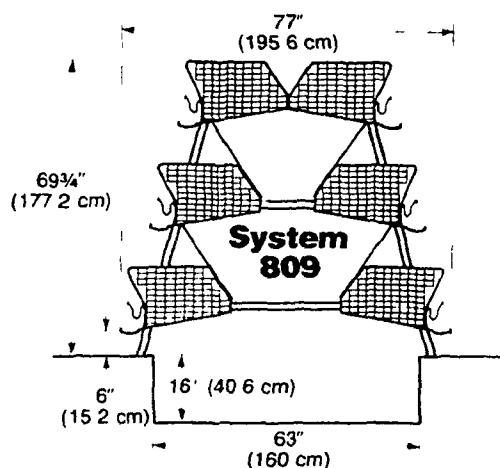

Exclusive Contour Cage gives birds more room

LET FARMER BOY PRICE YOU ON UPDATING YOUR EXISTING SYSTEM OR BUILD YOU A NEW TURNKEY COMPLEX

THIS OFFER IS FOR A LIMITED TIME ONLY

LOOK TO FARMER BOY FOR A COMPLETE SYSTEM INCLUDING BUILDINGS AND EQUIPMENT

SWINE & POULTRY SYSTEMS SPECIALISTS

FARMER BOY AG. INC.

410 E LINCOLN AVE

MYERSTOWN, PA 17067

PH 717-866-7565

BEST IN DESIGN, PRICE AND EXPERIENCE