

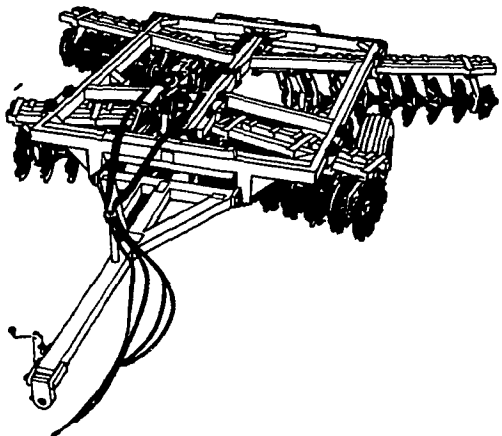

READY FOR THOSE FALL CHORES?

SPERRY NEW HOLLAND HAS THE EQUIPMENT TO HELP YOU GET THOSE FALL JOBS DONE EASILY AND EFFICIENTLY. WE ALSO HAVE THE FINANCIAL SERVICES — WAIVER OF FINANCE ON MANY PRODUCTS; NO INTEREST FINANCING, RENTAL PURCHASE AND LEASE PLANS. SEE YOUR SPERRY NEW HOLLAND DEALER LISTED ON THE OPPOSITE PAGE FOR ALL THE DETAILS!

TILLAGE - SPERRY NEW HOLLANDS "BREAKING NEW GROUND" WITH TANDEM AND OFFSET DISKS



1. MODELS FROM 7½ FOOT TO 38 FEET WITH MANY BLADE OPTIONS
2. POSITIVE DEPTH CONTROL
3. HYDRAULIC LEVELING ON THE GO
4. WAIVER 'TIL MARCH 83 PLUS ALLOWANCES

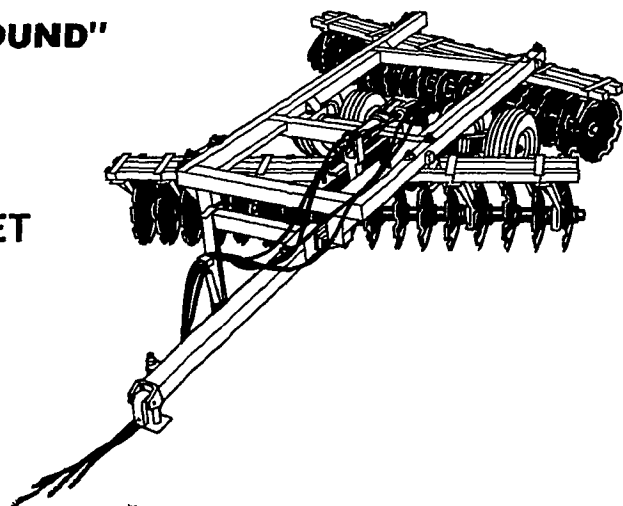

MATERIALS HANDLING - "SUPER BOOM", SPERRY NEW HOLLANDS SKID STEER LOADER DOES IT ALL

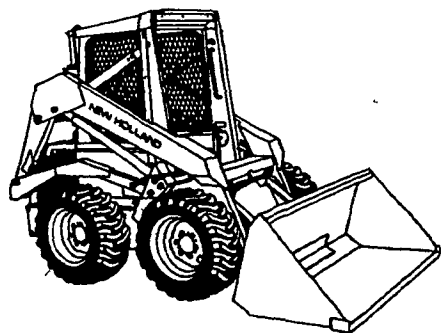

1. SEVEN MODELS WITH OPERATING LOADS FROM 900 TO 2050 LBS.
2. UNIQUE BOOM LINKAGE — GIVES YOU MORE REACH THAN OTHER CONVENTIONAL LOADERS
3. LOW CENTER OF GRAVITY FOR MORE STABILITY & SAFETY
4. CONVENIENT PLACEMENT OF CONTROLS

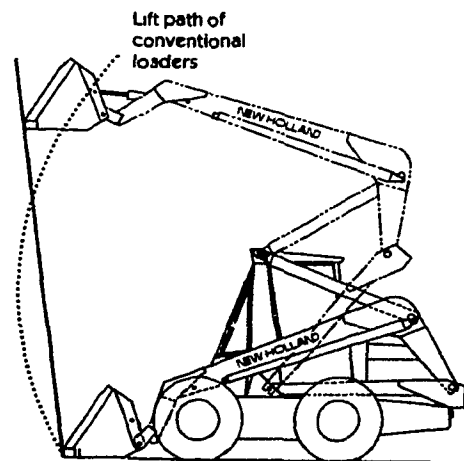

MANURE SPREADERS - "THE STRONG BOXES" FROM SPERRY NEW HOLLAND GET THE JOB DONE FAST

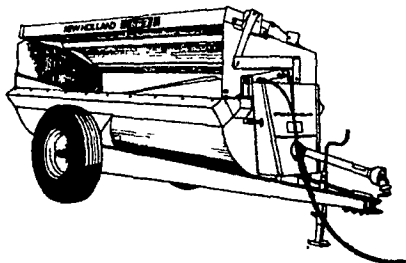

1. THREE NEW FLAIL SPREADERS FROM 739 TO 1064 GALLONS
2. LIFE TIME SIDE REPLACEMENT GUARANTEE ON ALL BOX TYPE SPREADERS
3. 100 LOAD LUBRICATION AND WORM GEAR DRIVE ON ALL BOX SPREADERS
4. INJECT FROM TRACTOR MOUNTED INJECTORS OR BROADCAST UP TO 40 FEET FROM OUR LIQUID SPREADERS - 3264 GALLONS OR 2222 GALLONS

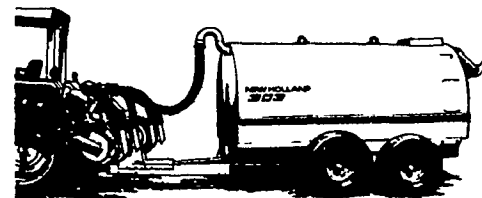
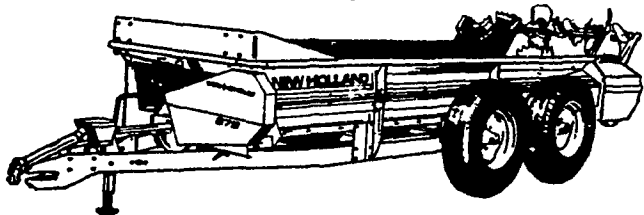
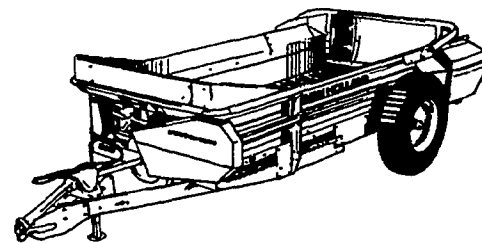

GRINDER MIXERS - SPERRY NEW HOLLANDS "FEED MAKER" EQUIPPED WITH MANY CONVENIENCE FEATURES

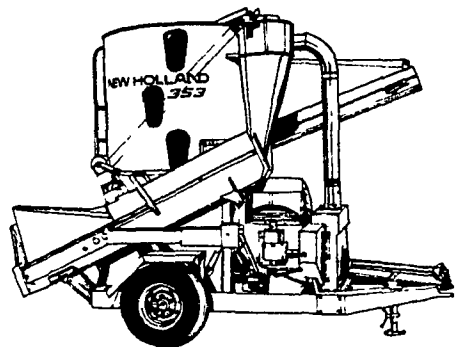

1. FOUR MODELS WITH 80 TO 150 BUSHEL MIXING TANK.
2. HYDRAULIC DRIVE AND ELECTRONIC SCALES MAKE THE JOB EASY.
3. POWER BALE FEEDER
4. DUAL REMOTE CONTROL UNLOADING AUGER

