

FARM EQUIPMENT

FARM EQUIPMENT

FARM EQUIPMENT

FARM EQUIPMENT

FARM EQUIPMENT

FARM EQUIPMENT

FARM EQUIPMENT

PARTS VALUE OF THE MONTH

Special Introductory Savings

ON IH ELECTRIC FENCING PRODUCTS

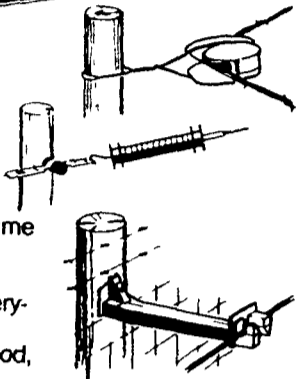
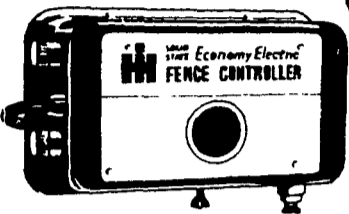

We have a new, complete line of IH electric fencing products, so now is the time to electrify or revitalize your fences at special savings.

- Five different models of 110-volt or battery-powered fence controllers.
- Complete selection of insulators for wood, T, or round metal posts.
- All controllers are U.L. listed.
- Full-year factory warranty, plus 30-day over-the-counter replacement warranty.

Save now during our **Farm'n' Ranch** sale



ERB & HENRY EQUIP. INC.

New Berlinville, PA 1 Mile N. of Boyertown
Phone (215) 367-2169

Daily 7 to 5; Sat. 7 to 3

BRICKERVILLE EQUIPMENT

SALES * SERVICE * PARTS

537 E. 28th Div. Hwy. Lititz, PA 17543

717-626-6198

Outstanding Features

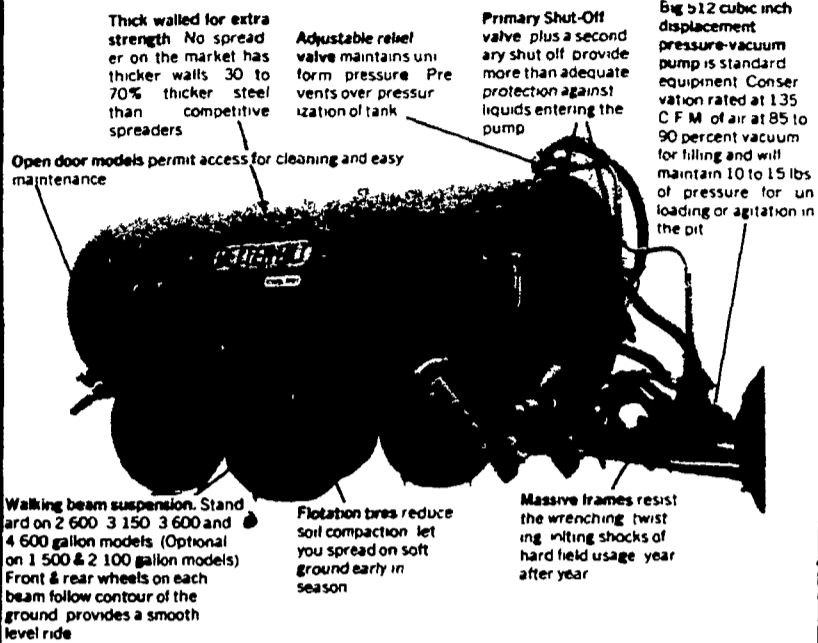

Thick walled for extra strength. No spreader on the market has thicker walls 30 to 70% thicker steel than competitive spreaders.

Adjustable relief valve maintains uniform pressure. Prevents over pressurization of tank.

Primary Shut-Off valve plus a secondary shut off provide more than adequate protection against liquids entering the pump.

Big 512 cubic inch displacement pressure-vacuum pump is standard equipment. Conservation rated at 135 C.F.M. of air at 85 to 90 percent vacuum for filling and will maintain 10 to 15 lbs. of pressure for unloading or agitation in the pit.

Open door models permit access for cleaning and easy maintenance.

Walking beam suspension. Stand on 2 600 3 150 3 600 and 4 600 gallon models (Optional on 1 500 & 2 100 gallon models). Front & rear wheels on each beam follow contour of the ground provides a smooth level ride.

Flotation tires reduce soil compaction. Let you spread on soft ground early in season.

Massive frames resist the wrenching twisting, rifting shocks of hard field usage year after year.

Sizes - 800 gal. thru 4600 gal.
Both vacuum & augermatic spreaders for truck mount or trailer type

SPECIAL
1 - USED BETTER BILT 2600 Gallon VACUUM SPREADER w/Tandem Axle and 4" Suction Hose, Plow Down Attach.

CALL US FOR YOUR NEEDS OF

- Farrowing Crates
- High Pressure Pumps
- Lagoon Pumps



NEW EQUIPMENT

- JD 850 Tractor
- JD 950 Tractor
- JD 1050 Tractor
- JD 2040 Tractor
- JD 714 Forage Boxes
- JD 1075 Running Gears
- JD 1207, 1209 Mower Conditioners
- Hesston 1014 Hyd Swing Conditioner
- JD 1710 Mulch Tiller
- Bush Hog 1432 10 1/2' Disc

USED EQUIPMENT

- ACC & WC Tractors
 - Farmall H, MD, Super M Tractors
 - JD B Tractor
 - JD 520 Tractor
 - JD 720 Tractor
 - JD 3010 RCU Tractor
 - Ford 8N Tractor
 - JD 494A Planter
 - IHC 350 Mulch Packer
 - IHC 540, 550 4B Plows
 - JD F125 6B Plow
 - Ferguson 2B Plow
 - JD AW Disc 12' Brillion 10 1/2' Offset Cutter
 - NH 6' Cutter
 - JD 507 Cutter
- Plus other new and used equipment
Call For Details
MILLER'S SALES & SERVICE INC.
West Penna. Ave. on Highway 851
Stewartstown, Pa.
717-933-2470 or 933-2732

TIME TO MAKE HAY WITH NEW IH HAY MACHINES

International® 425 Baler

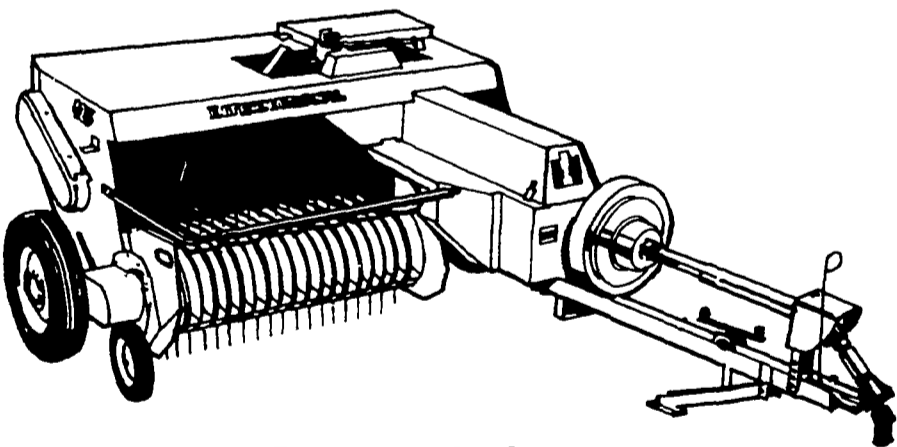

Economy priced, up to 15 tons per hour capacity

The new 425 is an economy baler with many of the same proven performance features found on other International 400 Series balers. It does an excellent job in most crops and conditions and is an ideal choice for farmers with average, moderate capacity baling requirements. Up to 15 tons per hour capacity.

- 61-in 4-bar pickup with 76 teeth sweeps the windrow clean
- 4,800 lbs of force behind the plunger for uniform, tightly packed bales
- Dependable Deering-type knotter tie strong secure knots
- Heavy duty drive train and 2-knuckle PTO. 3-knuckle PTO optional

International® 35 Parallel Bar Rake

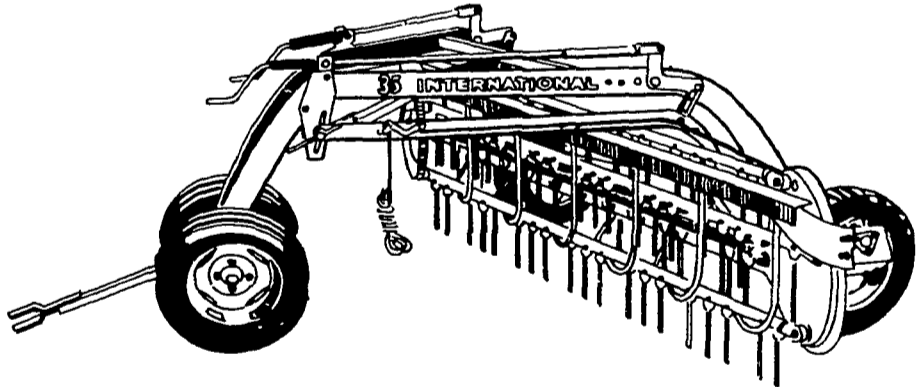

Get the best in gentle, high-capacity raking

Keep tight control over cost and quality with the 35 rake. Not only do you get clean raking at the right speed, but also the action to handle any crop from rank hay or thick sorghum to easily damaged beans. One major reason. Teeth are triple-grouped, rather than doubled, so they work like a fine-tooth comb—and they're rubber-mounted for flexibility and longer working life.

- Rakes a 9-ft swath
- Hydraulic drive, tedds or rakes
- Offset wheels are right behind basket for best work in uneven ground
- Built-in provision for adding fifth tooth bar, 5-tooth grouping
- Dolly wheel attachment helps prevent tooth "dig in" over extra rough fields (Available with dolly wheels or jack)

FINANCE PLANS AVAILABLE



HOURS
Mon. thru Fri. - 7 A.M. to 8 P.M.
Fri. - 7 A.M. to 5:30 P.M.
Sat. - 7 A.M. to 3 P.M.

R.S. HOLLINGER & SON, INC.

PARTS & SERVICE

113 W. Main St., Mountville, PA Ph: 717-285-4538



WANTED: SALESPERSON FOR AGRICULTURAL EQUIPMENT