

**John Deere
Quad-Range™ transmission —
The most productive blend of
synchronized and power shifts for 10 years**

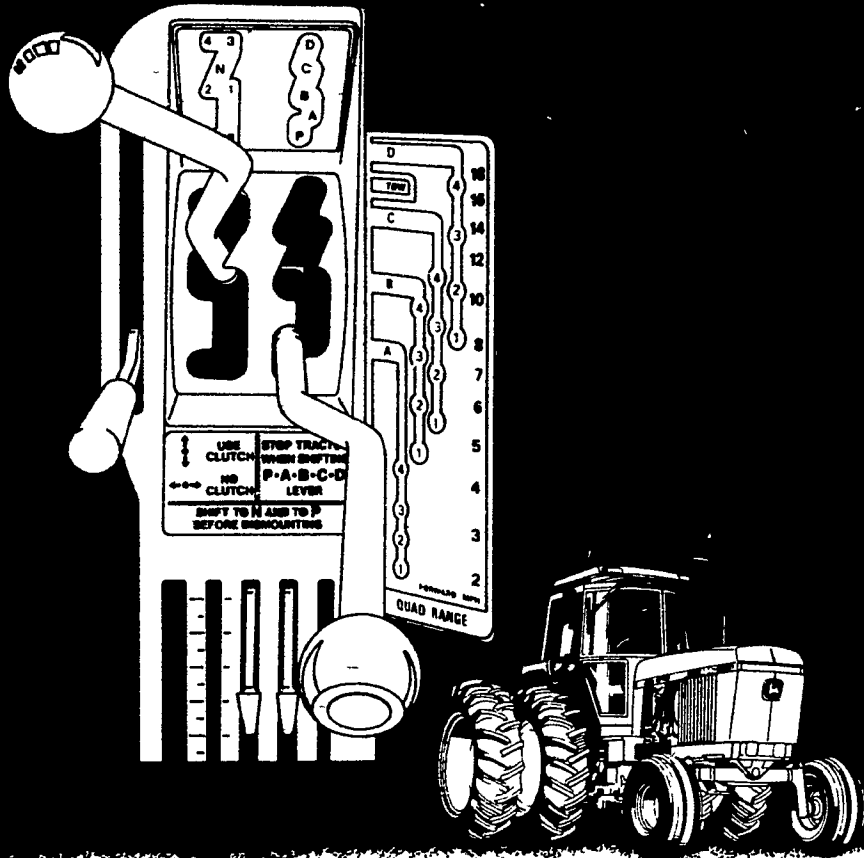

About 10 years ago, a lot of you came into our store to see a new John Deere transmission called Quad-Range

It was terrific. It had 16 speeds, with four speeds in four ranges. The ranges and speeds overlapped to provide a great choice of working speeds. And it had a built-in Hi-Lo so you could shift on the go between speeds 1 and 2 and between speeds 3 and 4 in all four ranges. You could make a synchronized shift between speeds 2 and 3.

It was a two-lever transmission. You selected the working range with one and did all your speed changes with the other. A simple "Z" pattern clarified everything.

What a success! Immediately it became John Deere's largest-selling transmission. So much so that it soon became standard equipment. The only rival was another John Deere transmission called Power Shift.

Now, 10 years later, nothing's changed. They're still the most modern, productive transmissions available. Stop in again.

Year after year, a John Deere seems newer

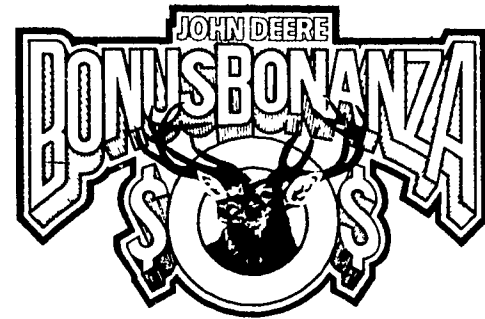

**For a limited time,
earn \$50 to \$1,200 in bonus buying power
by ordering a new John Deere disk,
hay or forage tool**

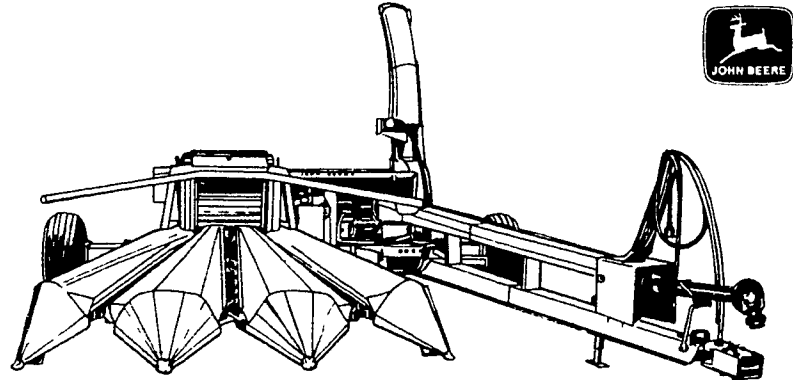

Order any new John Deere hay/forage tool or disk listed here and, during this special limited-time offer, you'll qualify for a bonanza of bonuses. You'll receive \$50 to \$1,200 in John Deere money you can exchange for goods or services at our store after you take delivery. From the time you order until we make delivery, you'll get price protection on any machine in this bonus program. And, no finance charges will accrue on a disk

purchase until March 1, 1982, or until the first of the month in which a hay/forage tool purchase will next be used in this area. Also remember this equipment could earn you investment tax credit in 1981 plus tax write-off under new depreciation schedules. So act now and save. Check the list and order before this Bonus Bonanza offer ends.

HAY AND FORAGE EQUIPMENT

MACHINE	BONUS IN JOHN DEERE MONEY
Square Balers	\$ 250
Round Balers	\$ 250
PTO Forage Harvesters	\$ 375
SP Forage Harvesters	\$1200
Mower/Conditioners	\$ 350
SP Windrowers	\$ 450
Ag Mowers	\$ 50
Rakes	\$ 50

DISKS

DISK MODELS	BONUS IN JOHN DEERE MONEY
111, 115	\$ 75
210, 215, 310, 315, 340	
1630, 1635	\$ 175
220, 230, 235, 350, 355	
440, 455, 1640	\$ 250
331, 335	\$ 425
370, 375	\$ 600

This finance offer may be withdrawn at any time.

A.B.C. GROFF, INC.
New Holland, PA
717-354-4191

**ADAMSTOWN
EQUIPMENT INC.**
Mohnton R D 2, PA
(near Adamstown)
215-484-4391

**CHAPMAN
EQUIPMENT CENTER**
Agway Inc
Chapman, PA
215-398-2553

**CLUGSTON
IMPLEMENT, INC.**
Chambersburg, PA
717-263-4103

J.S. COVERT & SONS
Neshanic Station, NJ
201-369-5241

OXFORD GREENLINE
Oxford, PA
215-932-2753-
215-932-2754

**EVERGREEN TRACTOR
CO., INC.**
Lebanon, PA
717-272-4641

**FOSTER EQUIPMENT
SALES**
Elmer, NJ
609-769-1535

**H.R. GUTSHALL
& SONS, INC.**
Carlisle, PA
717-249-2313

**ROBERT G. HAMPYON,
INC.**
Shiloh, NJ
609-451-9520

The Long Green Line™



**Nothing runs
like a Deere®**

TAM SERVICES INC.
RD 4 Box 77A
Gettysburg, PA
717-334-9148
717-334-3710

I.G. SALES
Silverdale, PA
215-257-5136

NEUHAUS'ES
York, PA
717-428-1953

KERMIT K. KISTLER INC.
Lynnport, PA
215-298-2011

LANDIS BROS. INC.
Lancaster PA
717-291-1046

ROBERT E. LITTLE INC.
Zieglerville, PA
215-287-9643

**PIKEVILLE EQUIPMENT
INC.**
Oyster Dale Road
Oley RD2, PA
215-987-6277

GEORGE V. SEIPLE & SON
Easton, PA
215-258-7146

**SHOTZBERGER'S
EQUIPMENT**
Elm, PA
717-665-2141

**TOBIAS EQUIPMENT
CO., INC.**
Halifax, PA
717-362-3132

WENGER IMPLEMENT, INC.
The Buck-Quarryville, PA
717-284-4141

**WOODHULL EQUIPMENT,
INC.**
Medford, NJ
609-654-2011

M.S. YEARSLEY & SONS
West Chester, PA
215-696-2990

**SMITH'S
IMPLEMENTS, INC.**
Mercersburg, PA
717-328-2244

**DON CHESKE
BROTHERS, INC.**
Hackettstown, NJ
201-852-4488

**PARKHURST
FARM SUPPLY**
Hammononton, NJ
609-561-0960

LIGHTEST ON THE SNOW

**1982 John Deere snowmobiles are light
in weight, heavy on innovations**

You are looking at one member of the lightest-weight line of snowmobiles in the industry. John Deere knows what excess weight can do to a snowmobile's performance: Slow acceleration, less maneuverability, increased fuel consumption. So John Deere pared its 1982 snowmobiles down to the muscle. No sacrifices, only improvements. Like direct drive, Ultra-Form 80 steel, TPR (thermoplastic rubber), redesigned components. Things you can't see, but you can sure feel. Experience the 1982 Spitfire, Trailfire and Trailfire LX, Sportfire and Liquifire® today.



Nothing Runs Like a Deere®

