

Youths sell livestock at Tioga

WHITNEYVILLE — The Second Annual Junior Livestock Sale was held August 15 as part of the Tioga County Fair at Whitneyville.

Clyde Beard of the Conwanesque Valley Livestock Market donated his auctioneering services, as 19 4-H and FFA youngsters sold 35 animals, including 13 market lambs, 11 market steers and 11 market hogs. The animals had been shown and judged earlier in the week.

Dairyland Farms was the successful bidder for the grand champion steer that was exhibited by Brian Zerby. The steer weighed 1175 lbs. and brought \$1.04 per



In ring with reserve champion hog at Tioga Junior Livestock Sale is seller, Susan Zerby, of Westfield.



With grand champion lamb at Junior Livestock Sale at Tioga County Fair are seller Stephanie Kocher and buyer Clyde Beard, of Cowanesque Livestock Market.

Red meat down

HARRISBURG — Commercial red meat production in Pennsylvania during July totaled 68.5 million pounds, down 13 percent from last year's figure, according to the Pennsylvania Crop Reporting Service.

Cattle slaughter, at 65,000 head, increased 11 percent compared to last July, while calf slaughter, at 20,900 head, decreased two percent. Hog slaughter, at 162,800 head, decreased 36 percent from last year at this time and the number of sheep and lambs slaughtered totaled 12,300 head, a decrease of three percent.

Nationally, commercial red meat production during July totaled 3.04 billion pounds, down one percent from last year.

pound or \$1,645,00. Headwaters Farm Credit Service was the successful bidder for the reserve champion that was exhibited by Scott Miller. The steer weighed 1005 lbs. and brought \$1.05 per pound.

The grand champion market hog was exhibited by Stephanie Kocher and weighed 225 lbs., Clyde Beard was the successful buyer at \$2.75 per pound. The reserve champion hog was exhibited by Susan Zerby and weighed 215 lbs. and was purchased by Headwaters Farm Credit Service for \$2.00 per pound.

The grand champion market lamb was exhibited by Stephanie Kocher and weighed 140 lbs. and

was purchased by Conwanesque Valley Livestock Market for \$4.00 per pound. The reserve grand champion was also exhibited by Stephanie Kocher, weighing 110 lbs. and was purchased by Boom and Painter for \$3.60 per pound.

Other buyers included Wellsboro, Mansfield, Knoxville and Cornell Brothers Agway, Dale Gee, Real Estaters of Wellsboro, David Good, Ned Kocher, Troy Sales, Thomas Thede, Gordon Gee, Herbert Ziff, George Staff, John Beard, Clark Bowen, Commonwealth Bank and Trust Company, Mohoning Creek Farms, Westfield Merchants and Libety Veterinar Clinic.

DRIVE A LITTLE, SAVE A LOT AT E.M. HERR'S!

ELECTRIC FENCE POSTS ROUND ROD STYLE

BUNDLED POSTS DARE SET—EZE®

Bundled 25's Not boxed Insulators not included 3/8" (23/64" dia) steel rod with wrap around anchor plate Aluminum finish Reg. 69¢ Cat.

No	Length	Wt.	Sale
SPEC 0-48	48"	31 lbs	Bundle of 25 \$14.75

130 VOLT BULB SPECIAL

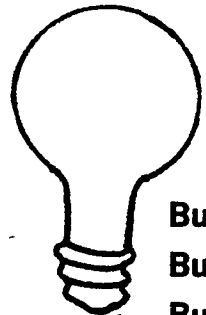

★ EARLY ORDER Call 717-464-3321
★ By The Case - 120 Bulbs Per Case

Buy 1 Case	72¢ each
Buy 2-5 Cases	68¢ each
Buy 5 plus Cases	63¢ each

Also Available in 15 - 25 - 40 - 60 - 75 and 100 Watts.

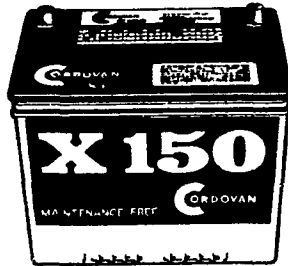

CORDOVAN BATTERIES

42 Month Warranty As Low As **\$36.95** With Trade In

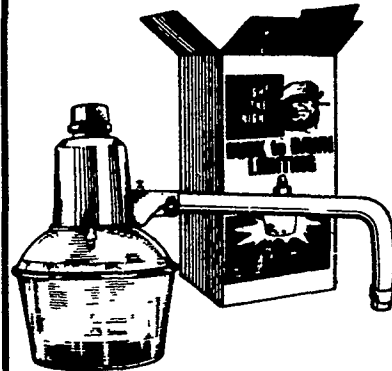

MERCURY VAPOR SECURITY LIGHT

Features a 175 Watt Mercury Vapor Lamp that lasts 30 times longer than 100 watt bulbs. Connects to a standard 120 volt outlet and automatically turns light on at dusk, and off at dawn. No. 33850

Reg. \$42.99 SALE **\$36.99**

TRUCKLOAD of CORN CRIBS COMING SOON!

Don't Buy Until You Call and Check Our Prices

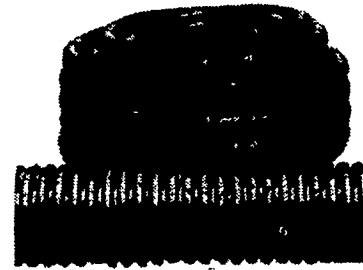

ADS ADVANCED DRAINAGE SYSTEMS, INC. FIELD DRAIN PIPE (ASCS Approved)

4" Solid or Perforated 6" Solid or Perforated Also Available in 8", 10", 12", 15", 18" CALL FOR QUANTITY PRICES

4" ... **24¢** Per Foot (By the Roll)

KORY GRAVITY BOX Model S-165

• Sills - 7 ga. • 165 Bu • 970 lbs. • Heavy • 60" Height Duty

Reg. 499.95 Sale **\$469.95**

220 Bu Reg 635.95 Sale **\$599.95**

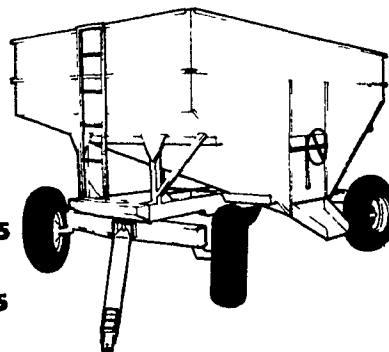

RUNNING GEAR

• Standard Tongue • Adj. Wheel Base • 6 Bolt Hubs Less: Wagon & Tires

10 TON	Reg. \$599.95	Sale \$569.95
8 TON	Reg. \$499.95	Sale \$469.95
6 TON	Reg. \$465.95	Sale \$435.95

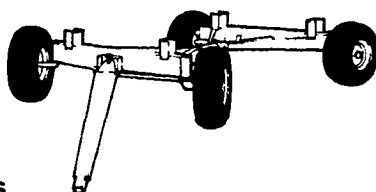

AUGERS

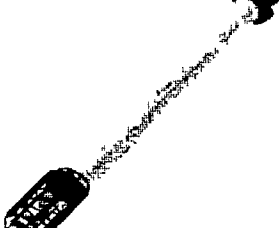

4"x10'	\$108.75
4"x15'	\$133.75
6"x11'	\$162.75
6"x16'	\$199.75

WE UPS ANYWHERE — JUST CALL 717-464-3321 SALE PRICES GOOD THROUGH SEPTEMBER 5

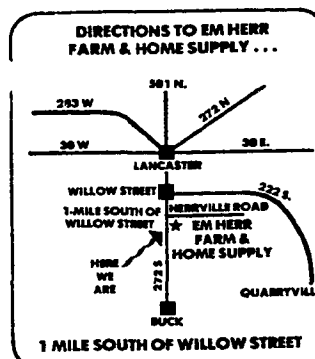

Store Hours
Mon.-Thurs. 7:30 A.M.-6:00 P.M.
Sat. 7:30 A.M.-5:00 P.M.
Fri. 7:30-9:00

E.M. HERR
FARM & HOME SUPPLY
R.D. 1, Box 272 South Harrisville Rd.
Willow Street, Pa.
Phone (717) 464-3321