

Stoltzfus sweeps

(Continued from Page A18)
 pany, Porkland, Leedy Packing Co., Jack Hess Feed Co., Cruetzburg Inc., John Snyder Packing, Ban-Mar Feeds, Downingtown



Mark Umberger was named Delaware County's Champion Junior Showman, during the recent Chester-Delaware swine show.

National Bank, Messina Packing Co., Emery Buying Station, John F. Martin, Ira Nissley Feeds, Philadelphia Pork, Levi Hertzog, Pickering Valley Feed Store, Farmland Meats, Honeybrook Farm Center, Vintage Sales Stables, Beams Shavings, John Stauffer, Bob Burns, Hamilton Bank.

More inclusive results of the show follows:

- Class I 180-190 lbs**
 1 Kellie Powers Del Co 2 David Trumbull Del Co 3 Kim Smith Del Co 4 Brendan Powers Del Co 5 Chris Umberger Del Co
- Class II 195-200 lbs**
 1 Keith Bryan Del Co 2 Tom Emery Chester Co 3 Chuck Myers Del Co 4 David Paterson Del Co 5 Lori Simasek Del Co 6 David Biedzenski Del Co 7 Greg Muldon Del Co
- Class III 205-210 lbs**
 1 Brian Beam Chester Co 2 Lois Bagshaw Chester Co 3 Kim Bryan Del Co 4 Kris Bryan Del Co 5 Dan DiCamillo Del Co 6 Ed Powers Del Co 7 Amy Simasek Del Co
- Class IV 215-220 lbs**
 1 David Denlinger Chester Co 2 Trude Marsh Chester Co 3 Alice Bagshaw Chester Co 4 Diane Stoltzfus Chester Co 5 Mike Stoltzfus Chester Co
- Class V 225-235 lbs**
 1 Nelson Beam Chester Co 2 Mike Richards Chester Co 3 Gloria Petersheim Chester Co Del Co 4 Rod Stoltzfus Chester Co 5 Allison Burns Chester Co
- Class VI 240-260 lbs**
 1 Scott Stoltzfus Chester Co 2 Sam Petersheim Chester Co 3 Steve Sylvester Chester Co 4 Paul Wickware Chester Co 5 Susie Burkhardt Chester Co

Pa. produce dealer ineligible to operate

WASHINGTON, DC. — Charles A. Cesnales, Jr., doing business as City Market in Butler, has become ineligible to operate in the produce industry after failing to pay a reparation award of \$10,220 for produce purchased between February and May of 1980.

USDA's Agricultural Marketing Service, which licenses produce firms under the Perishable Agricultural Commodities Act, had charged the firm with failing to pay the agreed price to a Pennsylvania wholesaler.

Charles Brader, marketing

official with AMS, said the firm had been given an opportunity to answer the charges but had failed to do so. Therefore USDA ordered payment of the amount claimed.

Cesnales is ineligible to conduct business subject to the act until the award is paid and may not be employed by or affiliated with any PACA licensee without USDA approval.

Under PACA, all interstate traders in fresh and frozen fruits and vegetables must be licensed by USDA. USDA is authorized to suspend or revoke a trader's license for violating the act.



At HERRS FARM and HOME SUPPLY, The Bottom Line Cost Is YOUR SAVINGS!

HOMELITE®

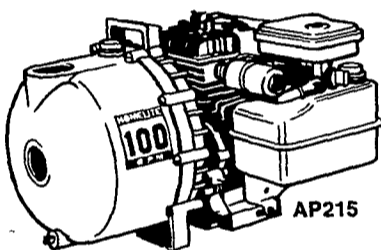

The shortest distance for moving water from here to there is a HOMELITE PUMP.

AP 215
 100 G.P.M.
 Reg. \$219.95

AP 220
 140 G.P.M.
 Reg. \$245.95

\$169⁹⁵ \$197⁹⁵

Grain AERATOR & DRYER

A must for busy farmers, no more costly moving of grain in your troubled hot areas. Economical drying and aerating of your grain in either flat or round storage. Gives instant action to remove hot spots and knock out moisture, aerates up to 5,000 bushels of grain at one time and up to 18 feet deep. Easily moved from bin to bin, contains a totally enclosed dust proof motor.



B&W Mfg
 Model 100
 Reg. \$79.49
 Model 128
 Reg. \$81.49

\$71²⁵

\$72⁰⁰

CREOSOTE WHITE

- Creosote/Oil Base Formula
- Glass Finish
- Good Durability
- Weather Resistant
- Easy to Apply
- Lead Free - Harmless to Livestock
- Economically Priced
- Ideal for Barn, Fences and all Farm Outbuildings



1 Gal. Reg. \$13.95
 2 Gal. Pail Reg. \$23.95
SALE \$10⁹⁵ \$19⁹⁵

WOVEN WIRE - KEYSTONE RED TOP BRAND

Height	Stay Space	Filler Ga.	Reg.	Sale
32"	6	12½	\$63.95	\$59.95
39"	12	12½	69.95	64.95
39"	6	12½	84.95	79.95
39"	6	11	112.95	105.95
47"	12	12½	69.95	63.95
47"	12	11	99.95	94.95
47"	6	11	125.95	119.95

FRONT TRACTOR TIRES

Stock #	Size	Ply	FET	Price
FF22	5.00-15	4	.69	21.99
FF38	5.50-16	4	.86	24.99
FF39	5.50-16	6	.97	26.99
FF40	6.00-16	4	.97	29.99
FF41	6.00-16	6	1.04	32.99
FF42	6.50-16	6	1.19	36.99
FF45	7.50-16	6	1.51	42.99
FF50	10.00-16	6	2.45	72.99
FF70	7.50-18	6	1.75	55.99

KORY GRAVITY BOX Model S-165

- Sills - 7 ga • 165 Bu.
 - 970 lbs • Heavy
 - 60" Height Duty
- Reg. 499.95 Sale **\$469⁹⁵**
 220 Bu
 Reg. 635.95 Sale **\$599⁹⁵**

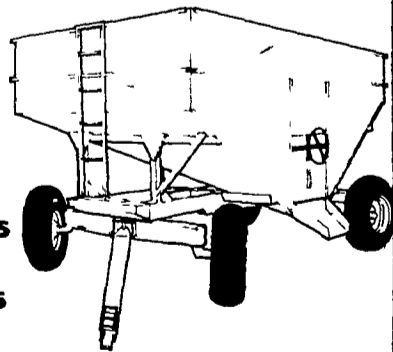

RUNNING GEAR

- Standard Tongue
 - Adj. Wheel Base
 - 6 Bolt Hubs
- Less: Wagon & Tires

10 TON	Reg. \$599.95	Sale \$569⁹⁵
8 TON	Reg. \$499.95	Sale \$469⁹⁵
6 TON	Reg. \$465.95	Sale \$435⁹⁵



Skuttle
 Electric, Portable
MOISTURE TESTER
 Reg. \$89.99

NOW \$69⁴⁹

AUGERS

4"x10'	\$108.75
4"x15'	\$133.75
6"x11'	\$162.75
6"x16'	\$199.75

Don't Buy Until You Call and Check Our Prices

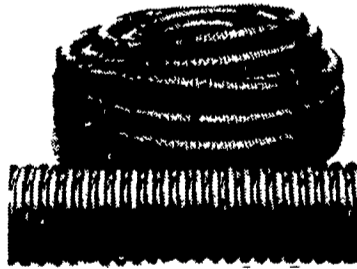

ADS FIELD DRAIN PIPE (ASCS Approved)

4" Solid or Perforated 6" Solid or Perforated
 Also Available in 8", 10", 12", 15", 18"
 CALL FOR QUANTITY PRICES

4" ... 24¢ Per Foot (By the Roll)

WE UPS ANYWHERE - JUST CALL 717-464-3321
 SALE PRICES GOOD THROUGH AUGUST 29

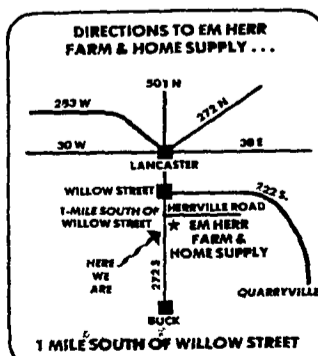

Store Hours
 Mon.-Thurs. 7:30 A.M. - 6:00 P.M.
 Sat. 7:30 A.M. - 5:00 P.M.
 Fri. 7:30-9:00

VISA® master charge

EMHERR

FARM & HOME SUPPLY

R.D. 1, Rtn. 272 South, Herrville Rd.
 Willow Street, Pa.
 Phone: (717) 464-3321