

Kemery NDC's nutrition information department

ROSEMONT, Ill. — Dale P. Kemery joined National Dairy Council as manager of its Nutrition Information Department, recently. He will direct NDC's nationwide nutrition information programs for consumers, scientists and health professionals.

NDC is the nutrition research and education arm of United Dairy Industry Association.

Kemery comes to NDC from California, where he operated his own media research and development company, The Media Analyst. The firm provided agricultural, health, construction, education and retail clients with public relations and marketing services. He has also served as Director of Special Projects for Dairy Council of California, an affiliated unit of NDC.

Kemery has 15 years of ex-

perience in broadcasting, including positions as news director, program director, reporter and announcer at stations in California, New York, Connecticut and Ohio. He has also published articles in numerous magazines and has done freelance reporting for National Public Radio, Associated Press and United Press International.

Kemery majored in journalism and communications at the University of Hawaii and California State University at Sacramento. He served with the Army in Vietnam as information specialist.

Kemery is a member of Sigma Delta Chi professional journalism society and a director of the Northern California Public Relations Roundtable. He was also active in several community and

professional organizations while in California.

National Dairy Council conducts its nutrition research and education activities as part of

UDIA's total promotion program for U.S.-produced milk and dairy products. The program, funded by member organizations representing producers, processors/handlers and dairy

equipment dealers and suppliers, includes the advertising and marketing services of American Dairy Association and the process/product projects of Dairy Research, Inc

US-USSR agree on one-year grain agreement extension

WASHINGTON, D.C. — Secretary of Agriculture John R. Block said he is "very pleased" with last Wednesday's announcement that U.S. and USSR negotiators have agreed on a one-year extension to the current Long Term Grains Agreement between the two nations.

The announcement was made in Vienna, Austria by U.S. Trade Representative William Brock,

who just concluded three days of discussions with representatives of the Soviet Union. It was also agreed that the two nations would begin detailed and in-depth examination of a new Long Term Grains Agreement. The next session of talks is planned for later this fall.

"I am very pleased that we have been able to re-establish this trade relationship on wheat and corn,"

Block said. "I am equally pleased that we now have a mechanism for future talks. I also want to compliment Ambassador Brock for the excellent effort he has put forth in Vienna."

The current Long Term Agreement was scheduled to end September 30. No changes will be made in that agreement, except that the expiration date has been extended to September 30, 1982.

PUT YOUR JUNK IN A BOTTLE!

FREE ANTIFREEZE

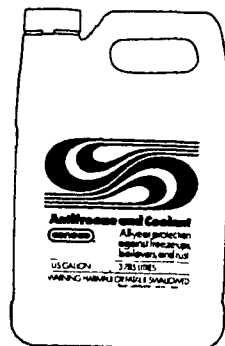
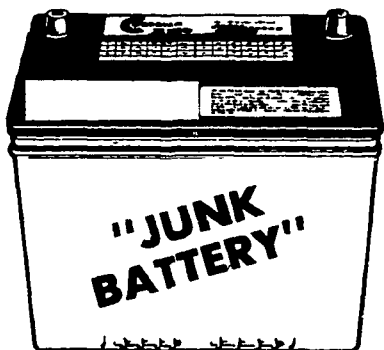

Receive 1 Gallon of Antifreeze **FREE** When You Bring Us a Junk Battery
We reserve the right to limit quantities

FRONT TRACTOR TIRES

Stock #	Size	Ply	F.E.T.	Price
FF22	5 00-15	4	69	21.99
FF38	5.50-16	4	86	24.99
FF39	5 50-16	6	97	26.99
FF40	6 00-16	4	97	29.99
FF41	6 00-16	6	104	32.99
FF42	6 50-16	6	119	36.99
FF45	7 50-16	6	151	42.99
FF50	10 00-16	6	245	72.99
FF70	7 50-18	6	175	55.99

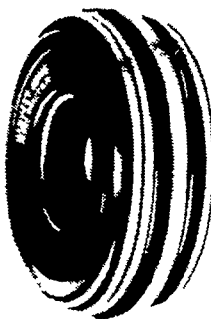

MURRAY MOWER CLEARANCE "Priced To Move"

Make us an offer, no reasonable offer refused. Limited to stock on hand.

- (2) 11 H.P. Riders
- (2) 8 H.P. Riders
- (1) 5 H.P. Rider
- (2) 3½ H.P. Push Mowers, 20" Mulcher
- (3) 3½ H.P. Push Mowers, 22" Deluxe

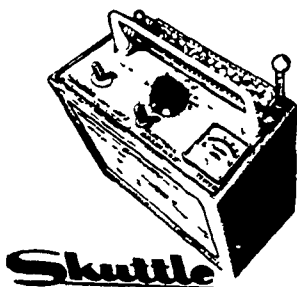

Skuttle
Electric, Portable MOISTURE TESTER
Reg. \$89.99

NOW **\$69.49**

TRUCKLOAD

Don't Buy Until You Call and Check Our Prices

of CORN CRIBS COMING SOON!



TUBULAR STEEL CATTLE & HOG GATES

For Corrals/Feedlots/Crowded Areas

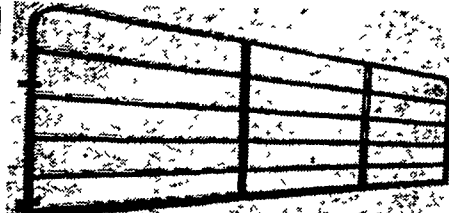

SIZE	O.D. 1-5/8"	O.D. 2"
8'	46.95	—
10'	49.95	—
12'	61.50	79.95
14'	69.50	92.95
16'	74.50	99.95
18'	—	109.95

Cattle Gates 50" High Complete with Hinges & Latch



ALUMINUM ROOF COATING

- Good for mobile home
- Insulates summer & winter
- Reduces noise

Reg \$36.95
SALE **\$29.99**
5 gal can



ASBESTOS FIBERED, 5 GALLONS, BLACK ROOF COATING

- Fills Small Cracks
- Prevents Leaks
- Protects Roof

Reg \$14.95
SALE **\$11.99**

KORY GRAVITY BOX Model S-165

- Sills - 7 ga
- 165 Bu
- 970 lbs
- Heavy Duty
- 60" Height

Reg 499.95 Sale **\$469.95**

220 Bu Reg 635.95 Sale **\$599.95**

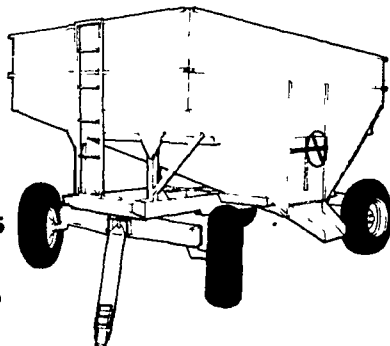

RUNNING GEAR

- Standard Tongue
- Adj. Wheel Base
- 6 Bolt Hubs
- Less: Wagon & Tires

10 TON Reg. \$599.95 . Sale **\$569.95**
8 TON Reg. \$499.95 . Sale **\$469.95**
6 TON Reg. \$465.95 . Sale **\$435.95**

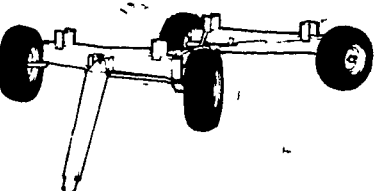

AUGERS

- 4"x10' **\$108.75**
- 4"x15' **\$133.75**
- 6"x11' **\$162.75**
- 6"x16' **\$199.75**

WE UPS ANYWHERE - JUST CALL 717-464-3321
SALE PRICES GOOD THROUGH AUGUST 22

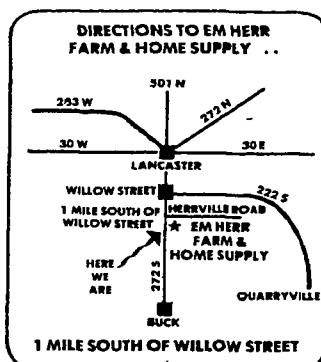

Store Hours

Mon-Thurs 7:30 A.M.-6:00 P.M.
Fri. 7:30-9:00
Sat. 7:30 A.M.-5:00 P.M.

VISA master charge

EMHERR FARM & HOME SUPPLY
R.D. 1, Rte. 272 South, Herrville Rd.
Willow Street, Pa.
Phone: (717) 464-3321