



Talk to the man who knows

Pump...Agitate...Fill! The versatile Badger Northland Pump/Agitator is available now! The portable Badger Northland BN 103 is built for years of tough, dependable, high capacity performance. It's versatile enough to handle anything you can give it. Designed to pump and agitate pits or lagoons, it can also be used as a manure transfer system for transferring manure from holding pits to lagoons or other storage facilities. Choose the gearbox that matches your tractor's horsepower and PTO RPM.

The BN 103 features an agitator nozzle which sweeps a full 300° for thorough agitation. Reaches all corners of the pit or lagoon.

Add to this the pitched blade of the "Souper-Charger" which moves material into the impeller for smooth, uniform high capacity pumping. The semi-cupped design of four paddles develops more pressure for mixing settled solids. Breaks up crust.

See your Badger dealer now. Ask him to show you how the BN 103 and other Badger manure handling products can add dollars and cents efficiency to your operation.

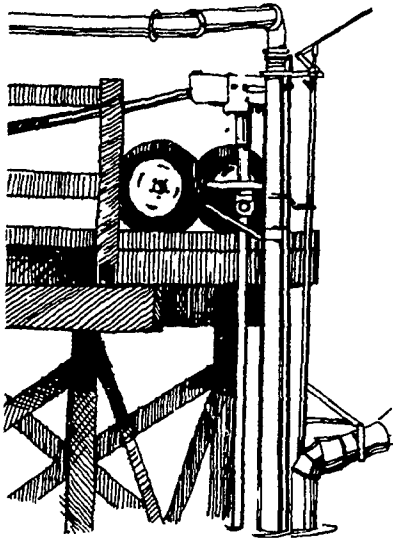

The Badger Souper-Trail Lagoon Agitator/Pump for long reach . . . fast agitation and fast fill.

Now you can pump solid or liquid manure from storage basins quickly and efficiently without the need for ramps or docks.

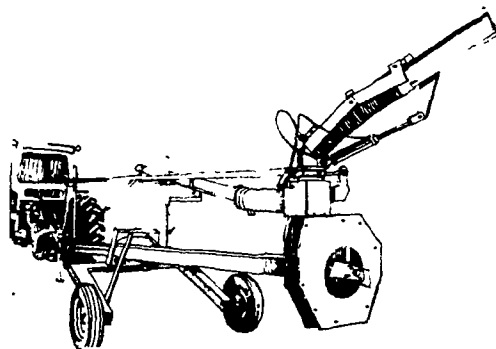

That's right. The Badger Souper-Trail Agitator/Pump is a powerful, rugged and versatile piece of equipment. It transports easily behind your tractor.

The Souper-Trail is easy to position and can be used in any depth lagoon. And its long reach and high capacity pumping allows for fast economic agitation of large manure basins. It will quickly fill even the largest manure tank.

Other features include a special chopper blade rotating ahead of the impeller housing. The heavy-duty hydraulic controlled spout breaks up large clumps and surface crust. Mixes settled solids.

Your dealer has two Souper-Trail models available for use with either 540 or 1000 tractors. See him now and count on him for all your manure handling system needs.

No agitation job is too tough for the Souper Mix Blender!

Now you can quickly restore that heavily crusted and weed covered manure basin to a free-flowing slurry for easy pumping.

The Souper Mix Blender is built tough to last with rugged construction throughout. Features large aggressive propeller with strong 3 point hitch.

See your Badger dealer now. Ask him for his ideas on how to achieve efficient profitable manure management in your operation.

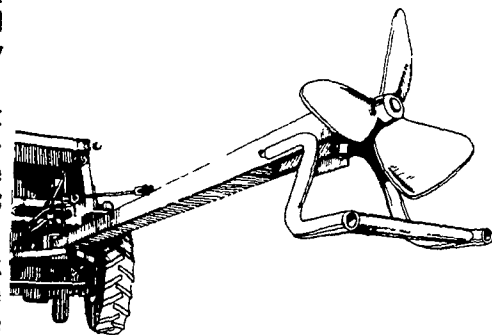

The best built, fastest and easiest unloading spreaders money can buy!

You convert to a liquid manure system to save time and labor and increase the overall efficiency of your operation.

You don't want to buy short when it comes to unloading and spreading equipment. And that's where the Badger 8700L, 5800L, and 3900L vacuum tanks come in. These husky vacuum spreader tanks unload fast. Cuts field and tractor time. 8700L and 5800L feature rugged "walking tandems" that make spreading easier, even in rough fields. 5800L and 8700L tanks are also available in models with spreader capabilities.

The Badger 11000L...for BIG jobs. Here's a tank with time saving capacity. 3000 gallons big, it means fewer trips with less labor. Supported by two pairs of large flotation tires, the Badger 11000L literally floats over plowed fields or rough roads. Other features include full length skid supports, extra heavy "A" frame tongue, hydraulic controls and a tractor actuated braking system.

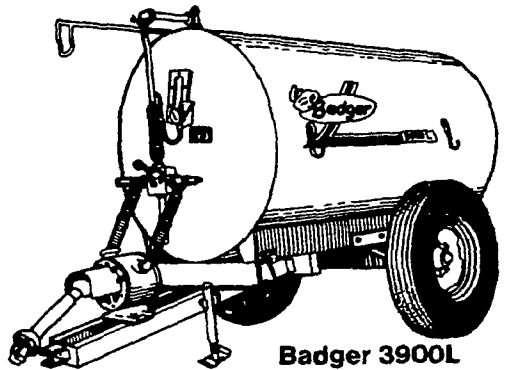

Badger 3900L

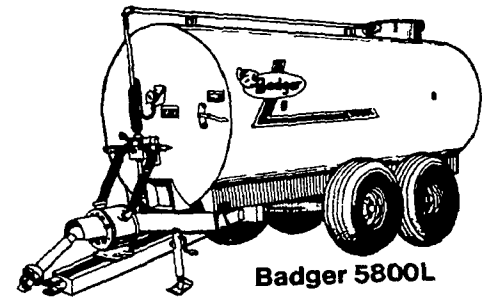

Badger 5800L

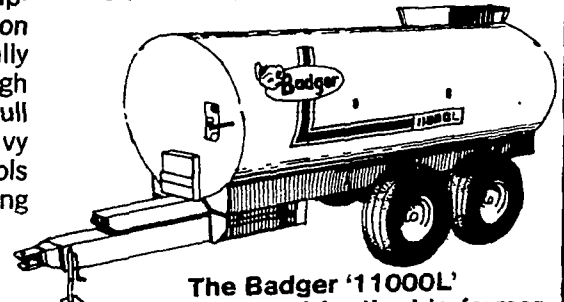

The Badger '11000L' Designed for the big farmer.

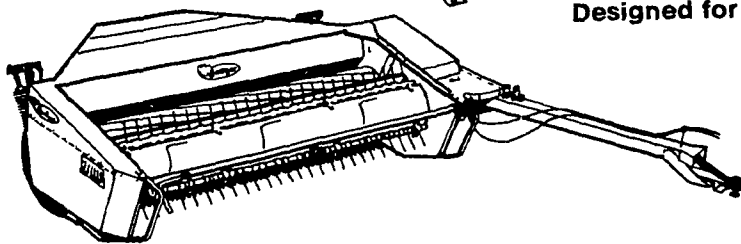

Take it all off with a Badger Northland Mower/Conditioner!

Even in the toughest of conditions, the Badger Mower/Conditioner will perform its "clean cutting" duties like no other, without over conditioning.

SPECIAL IN SEASON WAIVER ON MOWER/CONDITIONERS TILL SEPTEMBER 1, 1981

WAIVER OF FINANCE ON LIQUID MANURE TANKS & PUMPS TILL OCT. 1, 1981

Your Equipment and Service Professionals in this area are:

GRUMELLI'S FARM SERVICE

Mechanics Grove
Quarryville, PA 17566
(717) 786-7318

McMILLEN BROS.

RD 1
Loysville, PA 17047
(717) 789-3961

MECKLEY'S GARAGE, MANDATA

Div. of Meckley's Limestone
Products Inc.
RD1, Herdon, PA 17830
(717) 758-3915

SHOW-EASE STALL CO.

523 Willow Rd.
Lancaster, PA 17601
(717) 299-2536

ROY O. CHRISTMAN

RD 1
Hamburg, PA 19526
(215) 562-7218

JOHN BROWN

RR 1
Forks ville, PA 18616
(717) 924-3492

PIKEVILLE EQUIPMENT INC.

RD 2
Oley, PA 19547
(215) 987-6277

LLOYD E. KREIDER

RD 1
Cochranville, PA 19330
(215) 932-4700

RALPH KETTERER

Deep Run Road
Perkasie, PA 18944
(215) 766-8531

MARLIN W. SCHREFFLER

Pitman, PA 17964
(717) 648-1120

KNUD HERMANSEN

RD 2
York Springs, PA 17372
(717) 528-4762

MELVIN G. MILLER

RD 2
Spring Mills, PA 16875
(814) 442-8279

LEONARD WOK

RD 3
Brookville, PA 15825
(814) 849-3361

CECIL DAIRY SERVICE

RD 1 Rt. 274
½ Mi. South Rising Sun, MD 21911
(301) 658-6923

C. PAUL FORD & SON

RT 1
Everett, PA 15537
(814) 652-2051

HONESDALE SPREADING SERVICE INC.

(Formerly Buckingham Dairy Supply)
505 Cliff St. Honesdale, PA 18431
(717) 253-2410