

Going OUT OF BUSINESS

<p>ALL NEW EQUIPMENT ON INVENTORY SOLD AT DEALER NET.</p>	<p>2.5% OFF PARTS</p>	<p>NO REASONABLE OFFER REFUSED</p>
--	----------------------------------	---

- Farmall 1066 - rebuilt engine, TA, brakes, turbo, 20.8x38 tires, new paint, excellent condition \$15,500
- Allis Chalmers 190XT Series III w/cab, - 20.8 tires, weights, 2000 hours, excellent condition, one owner \$10,000
- John Deere 4030 Diesel w/4 post frame, like new tractor w/dual valves & weights, 495 hrs., one owner \$15,900
- Farmall 656 Diesel Hydro w/wide front, dual valves, new paint, 70 HP, one owner \$6,000
- Farmall 460 Tractor, TA, fast hitch, good mechanical condition, good appearance \$1,950
- Farmall 350 Tractor w/fast hitch, good used tractor, good tires \$1,500
- Farmall super MTA, power steering, live hydraulics, Independent PTO, Torque Amplifier, popular tractor \$1,895
- Ford Jubilee w/loader, hyd. dump, good clean tractor \$2,300
- 184 Cub Lo Boy equipped with terra tires \$4,165
- IH #1460 Axial Flow Combine w/#863 Corn Head, cream puff, like new machine at used price, 490 hrs., one owner \$56,000
- John Deere 14T Baler, good cheap baler \$425
- IH #205 Combine, 1972 Model, 6 cyl. engine, cab, 13 ft. platform, pickup reel, power steering, very good used combine, priced right \$6,500

- John Deere 336 Baler w/Thrower, very popular baler, priced right \$3,250
- Fox IF546 Forage Harvester w/Pickup & 2 row row crop unit, good inexpensive harvester \$800
- IH #50 Forage Harvester w/Pickup & 2 row row crop unit w/engine drive, IH engine, very good condition \$1,800
- IH 1150 Grinder-Mixer, one owner, good used mill, cheap price \$2,250
- Badger Forage Box 16 foot, 3 beater, roof, tandem axle gear, one owner, good condition \$2,500
- Grove 16' Forage Box, 72" sides, three beater, make offer \$750
- Papec 54" Forage Blower, good cheap blower \$400
- IH #40 Manure Spreader, three beater, new web, better than average \$400
- Hawk Bilt Tank Spreader - approx. 150 bushel, make offer \$400
- IH #455 Corn Planter, 4 row w/double disk openers, Buy now for next year, priced right \$1,000

**NEW 4140 DIESEL INTERNATIONAL
SKID STEER LOADER**

With Manure Fork & Material Bucket

\$13,175

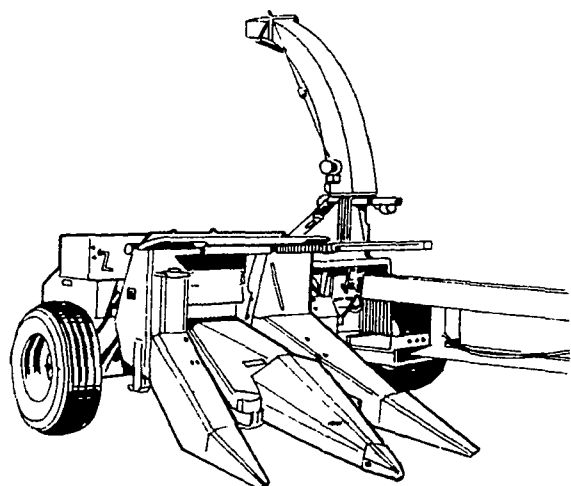

IH 720 HARVESTER
With 2 Row Row Crop Unit
\$8100

Plus...An Additional Customer Cash Payment of \$925 From International

IH 830 HARVESTER
With 2 Row Row Crop Unit
\$9250

Plus...An Additional Customer Cash Payment of \$925 From International

USED TRUCK SPECIALS

- 1975 International 1700, 205 inch wheel-base, 26,000 G.V.W., P.S., 5 speed transmission, 2 speed rear, reinforced frame, tilt hood, 404 engine, inspected, good condition \$5250
- 1975 International 200 1 Ton Dual Wheel with 12' Flat Body
- 1975 International 4 Wheel Drive Pickup with 8' Bed
- 1980 Scout Diesel Pickup

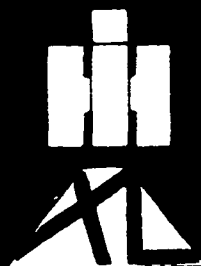

HERITAGE

INTERNATIONAL INC.

★ TRY OUR CERTIFIED SERVICE

1054 SOUTH STATE ST., EPHRATA, PA 17520
PHONE 717-733-2283

★ WE HAVE PARTS TOO