

# HARSH HOISTS

WHY BUY A COPY...WHEN YOU CAN HAVE THE ORIGINAL?



**RL-108**  
TBEA Class G  
16' to 20' Body

- Thirty years as the leader in hoist design and research makes HARSH the name to be trusted in hydraulic hoists.
- Unique telescopic scissor hoist.
- Models available to fit 12-26 ft. bodies.
- The one-piece Rigid-Lift hoist weighs less than the competition's hoist and "add-on" unit.
- HARSH's one-piece unit is quickly installed.
- And best of all, the price of an original HARSH Rigid-Lift hoist is competitive with all the copies!

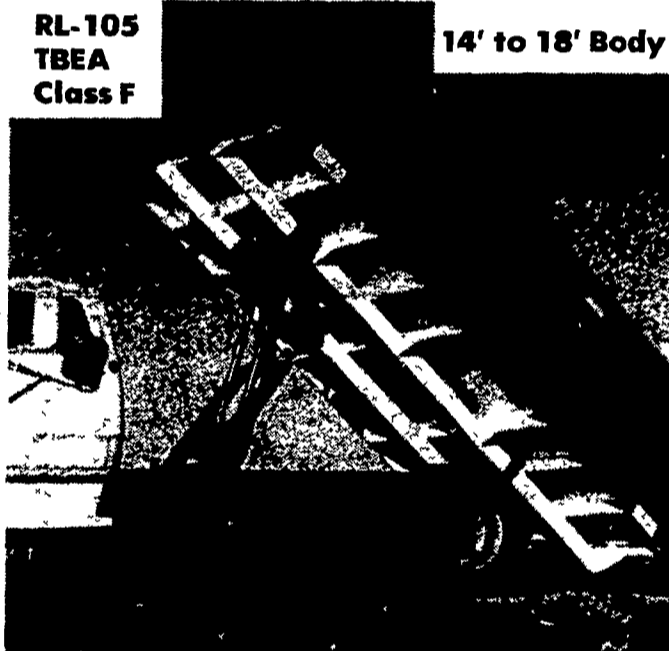

**RL-105**  
TBEA Class F  
14' to 18' Body

## HARSH HOIST LOW PROFILE-090

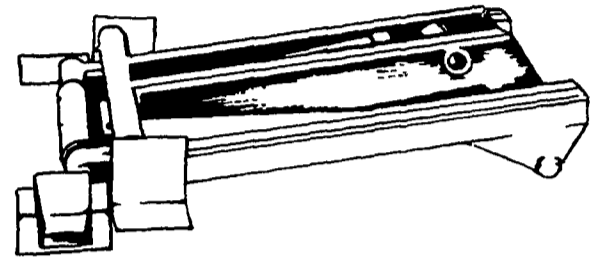

- Now a Hoist for 8' to 13'6" Body Lengths — TBEA Class C
- 6" Mounting Height — No Notching of Box Cross Members on 6" Longitudinal
- Available with Electric or P.T.O. Driven Pump
- Double Acting Cylinder Power Up / Power Down
- High Polish Hard Chrome Cylinder for Long Life

### WE NOW HAVE IN STOCK HARSH TRUCK SUSPENSIONS

"TRACTION-LIFT" HEAVY DUTY PUSHER OR TAG HYDRAULIC

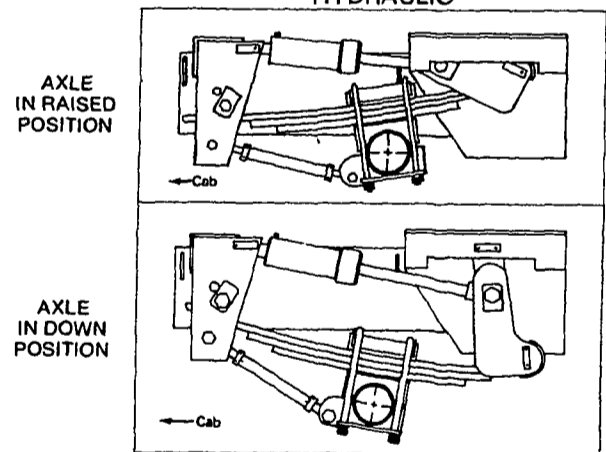

## HARSH FUEL TANKS

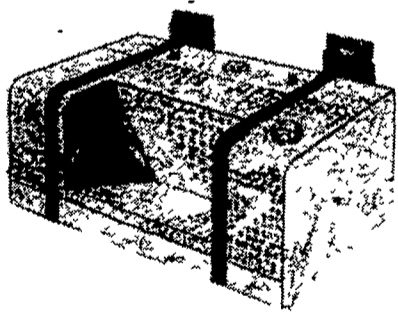

**50 GAL. STEP TANK**  
\$380.00 w/Brackets

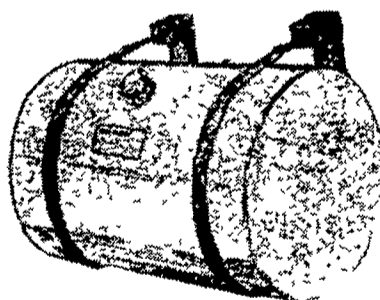

**CENTER FILL MODEL**  
30 gal. - \$223.00  
40 gal. - \$253.00  
50 gal. - \$273.00  
60 Gal. - \$293.00

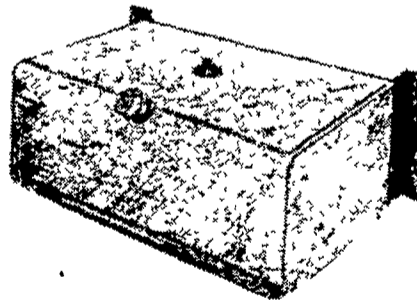

**SCHOOL BUS TANK**  
30 gal. - \$208.00  
40 gal. - \$233.00  
50 gal. - \$265.00  
60 gal. - \$290.00

Single Fuel Line Kit for above tanks: \$36.00  
Installation Charge: \$25.00 per tank

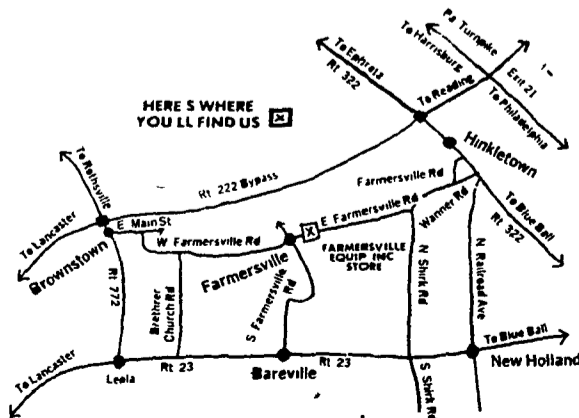

# FARMERSVILLE EQUIPMENT INC.

RD 4, Ephrata, PA.

HOURS: Mon., Tues., Wed. & Fri. 7:30 AM to 5:30 PM; Thurs. to 9 PM; Sat. till 3 PM

717-354-4271

COMPLETE LINE OF

**POWER TAKE-OFFS**  
IN STOCK