

FREE FINANCE* IS NOW AVAILABLE ON THE GRINDER-MIXER YOU ALWAYS WANTED!

Big performance...
compact machine.

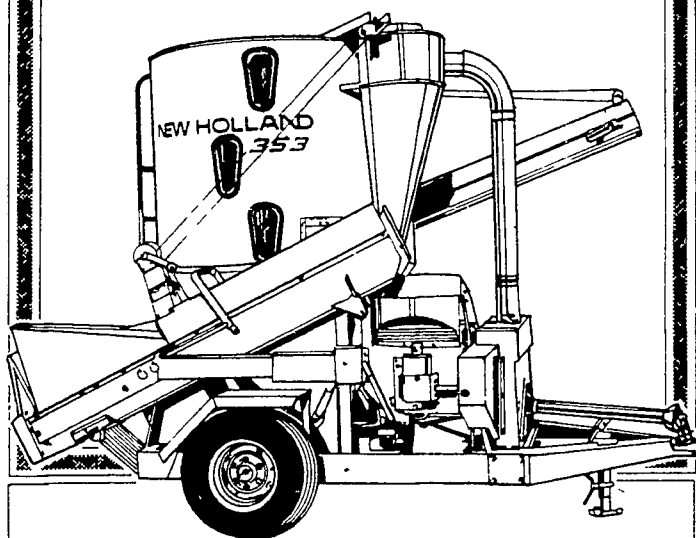

If you're shopping for a new grinder mixer, the Model 353 may be just the right model for you. It's a compact unit that's ideal for small to average feeding operations. It's also an ideal machine for the first-time buyer. The 353 features an 80 bushel tank with a 16-inch hammermill. The 10-foot base unloading auger, with choice of 3-, 7-, or 10-foot extension, gives you up to 20 feet of unloading reach. The optional electronic scale gives you accurate control of rations.



ONE LOOK AND YOU'LL BE CONVINCED A SPERRY NEW HOLLAND GRINDER-MIXER IS YOUR BEST BUY.

The feed processor.

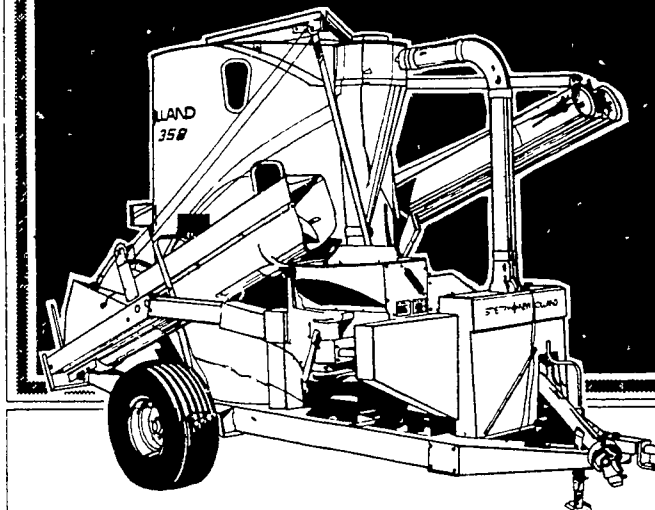

If you're in the market for a new grinder mixer, check out the Model 358 from Sperry New Holland. It's a modern farm feed processor. The special tank design practically eliminates bridging, no matter what crop you're grinding. The 358 features a 125 bushel tank, 21-inch hammermill, 540 or 1,000-rpm drive and mechanical or hydraulic drive. The 358 is available with power bale feeder, plain feed chute or loading auger.

100-bushel tank with a 21-inch mill.

The Sperry New Holland Model 355 grinder-mixer features a 21-inch hammermill and a 100-bushel tank. Choice of 10-, 13-, 17-, or 20-foot unloading augers lets you reach where you want. An optional electronic scale assures accurate control of rations.

Ask us to demonstrate on your farm.

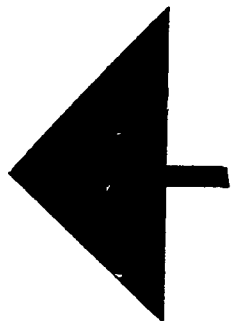
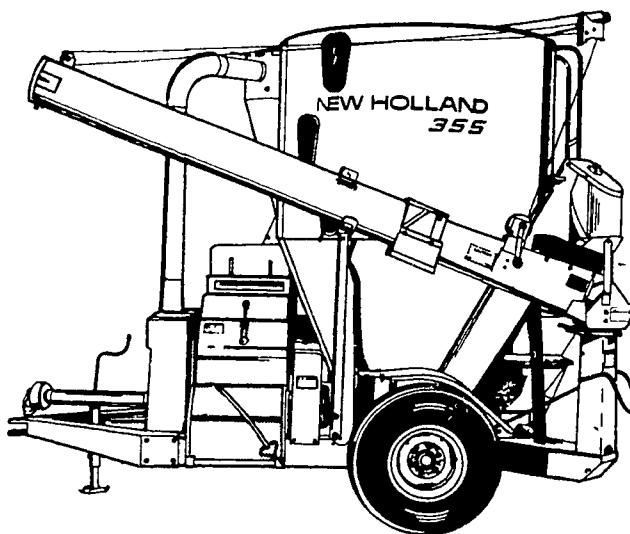

*** STOP IN AND VISIT YOUR NEAREST SPERRY NEW HOLLAND DEALER LISTED ON THE FACING PAGE. HE'LL BE HAPPY TO SHOW YOU HOW YOU CAN BUY THE GRINDER-MIXER YOU'VE ALWAYS WANTED WITH A SMALL DOWN PAYMENT NOW AND NO FINANCE CHARGES OR PAYMENTS UNTIL SEPTEMBER 1, 1981**

