

CENTRAL TRACTOR FARM & FAMILY CENTER

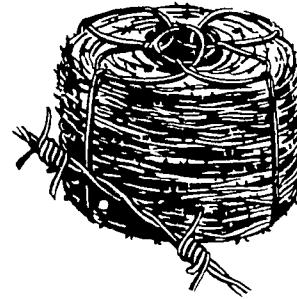

Hurry!
Sale prices good now through Sat., Mar. 7, 1981

SPECIAL SAVINGS



3197

Reg 34 97 / SAVE 3 00
24672-282
4 Pt. Barb Wire
12 1/2 gauge 4 pt wire 5 spacin
80 rod spools Made in USA

259

Reg 2 85 / SAVE 9%
24677-282
6' Steel "T" Pos

279

Reg 3 15 / SAVE 11%
24690-282
6 1/2' Steel "T" P
Strong durable studded with enamel finish for long life Includes five clips for attachment to fence post

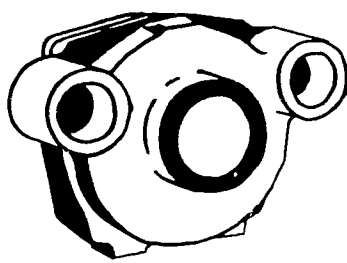

4497

Reg 47 97 / SAVE 3 00
6 Roller Pump 16380-100

5997 Reg 62 97 / SAVE 3 00
7 Roller Pump 16470 100

Roller Pumps

Backport pump with quick coupler jumbo nylatron rollers cast iron body with stainless steel drive shaft Pump capacity is 9.2 gpm at 550 rpm Pressure range is 0 to 200 psi

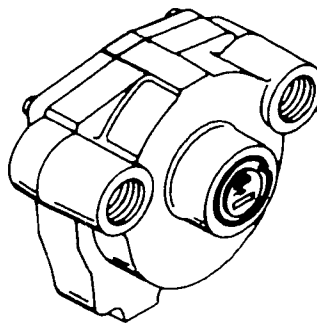

7997

Reg 86 97 / SAVE 7 00
16471-100

7 Roller Ni-resist Pump

7 roller twin port pump with quick coupler Ni-resist body jumbo nylatron rollers stainless steel shaft 15 gpm at 550 rpm Pressure range from 0 to 200 psi

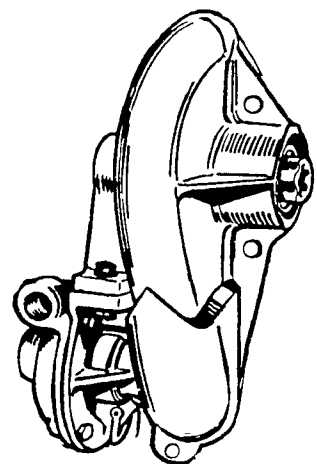

13488

Reg 139 99 / SAVE 5 11
16475-100

Ace Centrifugal Pump

Mounts directly on power take-off shaft. Sprays 20 gpm at 60 psi when driven by 600 rpm PTO. All iron construction sealed ball bearings spring loaded idler OSHA approved safety shield

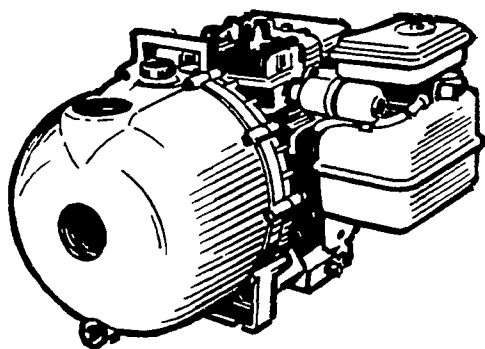

16999

Reg 184 99 / SAVE 15 00
16563-100

Gas Powered Centrifugal Pump

Self priming lightweight high volume portable pump Ideal for transferring agricultural chemicals from nurse tank to applicator tank 3 HP gas engine 90 GPM @3600 RPM 1 1/2" NPT inlet and discharge

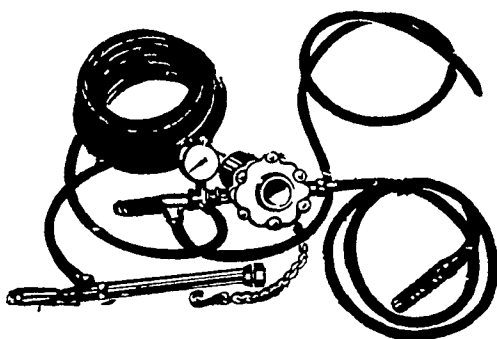

10499

Reg 114 99 / SAVE 10 00
W/5 Roller Pump 16375-100

12499 Reg 139 99 / SAVE 15 00
W/8 Roller Pump 16439-100

Sprayer Kits

Kit contains roller pump hi-pressure hand gun pressure gauge, stabilizer chain 10 of 3/4" suction hose 1/2" relief valve 25 of 3/8" 2 braid gun hose 6 bypass hose and fittings

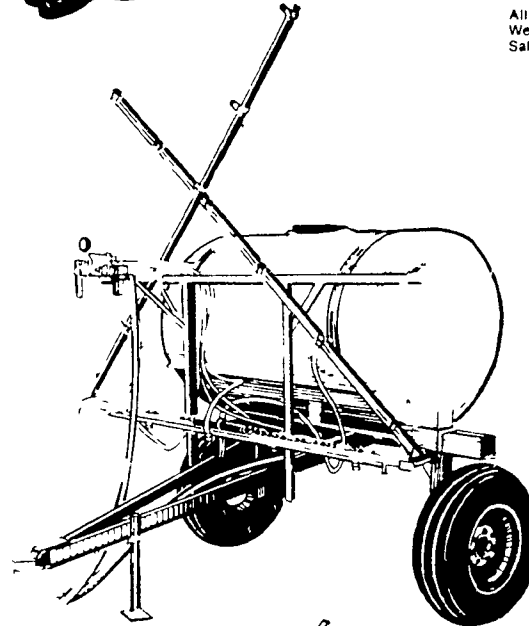

128999

Reg 1439 99 / SAVE 150 00
16560-100

500 Gal. Field Sprayer

This big 10 row 21 nozzle sprayer will give approximately 35 ft coverage Comes with 1/2" hose booms (standard EVA tubing) nylon fittings on booms and hoses and high speed Timken bearings and 15 rims (less tires) The heavy duty axle trailer gives you a 40 row width down to any row width desired plus complete visibility 20 GPA tips standard other tips available Less pump and tires

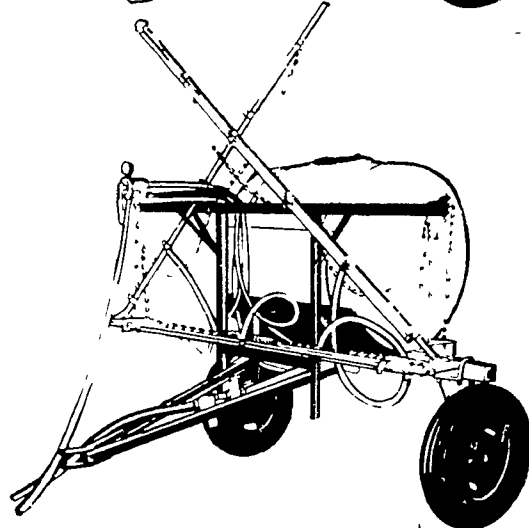

81999

Reg 919 99 / SAVE 100 00
200 Gallon 16440-100

92999 Reg 1049 99 / SAVE 124 00
300 Gallon 16511 100

Field Sprayer

Polyethylene tank 8-way selector valve 20 gallon tips 2 braid hose 1/2" suction hose and 1/2" nylon type strainer 8 row boom tread easily adjustable from 51 to 88 comes less pump and tires

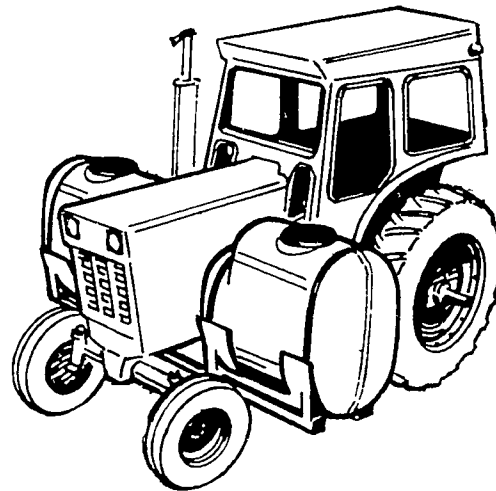

78999

Reg 889 99 / SAVE 100 00
300 Gallon 16593-100

84999 Reg 949 99 / SAVE 100 00
400 Gallon 16564 100

Side Mount Sprayer

Includes heavy duty tank carrier two tanks dual suction dual bypass dual jet agitators and manifold Optional planter and disc attachment kits available Comes less pump

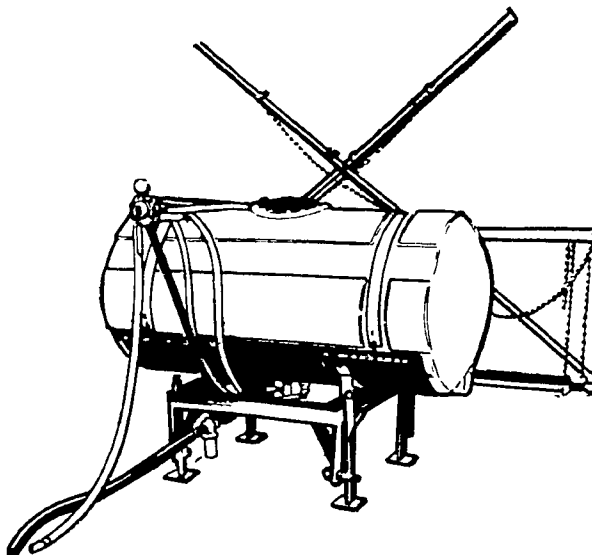

62999

Reg 699 99 / SAVE 70 00
150 gallon 16521-100

66999 Reg 759 99 / SAVE 90 00
200 gallon 16714 100

3 Pt. Sprayers

Quick easy to attach and simple to operate 3-point hitch 8 row sprayer with polyethylene tank Fits tractors with Cat 1 or 2 three point hitches 7/8" pins for category 1 order bushings to bush 7/8" pin to 1 1/8" for category 2 Less pump and lower link pins

