

## 215 Level-Action™ Disks

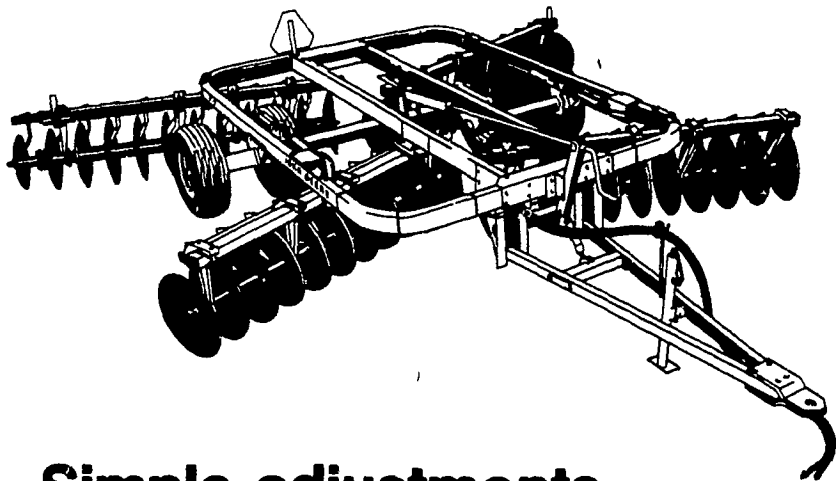

**Simple adjustments  
and tough bearings make  
these disks "simply tough"**

A leveling crank helps you disk without a center ridge or valley. Dura-Flex™ bearings lock dirt out and are backed by a 2-year warranty. And you can set the unique combination scrapers for soil types from sandy to gumbo.

Working widths range from 11 feet 5 inches to 15 feet 8 inches. Weight ranges from 75 to 100-pounds per blade.

## 110-hp 4240



**Smooth, dynamic power  
and plenty of it**

A genuine John Deere 6-cylinder diesel engine powers the 4240. It's a 466-cu-in naturally aspirated smoothie that pumps out 110 horsepower all day long without pause. But that's just one reason you're going to like this talented performer. Because hand-in-glove with the smooth power is the convenience of 16-speed Quad-Range™ transmission with built-in Hi-Lo. It delivers no-stop shift-on-the-go convenience and it's standard equipment. See us for more details.

**A.B.C. GROFF, INC.**  
New Holland, PA  
717-354-4191

**ADAMSTOWN  
EQUIPMENT INC.**  
Mohnton R D 2, PA  
(near Adamstown)  
215-484-4391

**CHAPMAN  
EQUIPMENT CENTER**  
Agway Inc  
Chapman, PA  
215-398-2553

**CLUGSTON  
IMPLEMENT, INC.**  
Chambersburg, PA  
717-263-4103

**J.S. COVERT & SONS**  
Neshanic Station, NJ  
201-369-5241

**OXFORD GREENLINE**  
Oxford, PA  
215-932-2753 -  
215-932-2754

**EVERGREEN TRACTOR  
CO., INC.**  
Lebanon, PA  
717-272-4641

**FOSTER EQUIPMENT  
SALES**  
Elmer, NJ  
609-769-1535

**H.R. GUTSHALL  
& SONS, INC.**  
Carlisle, PA  
717-249-2313

**ROBERT G. HAMPTON,  
INC.**  
Shiloh, NJ  
609-451-9520

### The Long Green Line™



*Nothing runs  
like a Deere®*

**I.G. SALES**  
Silverdale, PA  
215-257-5136

**DON CHESKE  
BROTHERS, INC.**  
Hackettstown, NJ  
201-852-4488

**KERMIT K. KISTLER INC.**  
Lynnport, PA  
215-298-2011

**LANDIS BROS. INC.**  
Lancaster, PA  
717-291-1046

**ROBERT E. LITTLE INC.**  
Zieglerville, PA  
215-287-9643

**PIKEVILLE EQUIPMENT  
INC.**  
Oyster Dale Road  
Oley RD2, PA  
215-987-6277

**GEORGE V. SEIPLE & SON**  
Easton, PA  
215-258-7146

**SHOTZBERGER'S  
EQUIPMENT**  
Elm, PA  
717-665-2141

**TOBIAS EQUIPMENT  
CO., INC.**  
Halifax, PA  
717-362-3132

**WENGER IMPLEMENT, INC.**  
The Buck-Quarryville, PA  
717-284-4141

**WOODHULL EQUIPMENT,  
INC.**  
Medford, NJ  
609-654-2011

**M.S. YEARSLEY & SONS**  
West Chester, PA  
215-696-2990

## Inflation fighters from John Deere...

# TILLERS IN A VARIETY OF SIZES

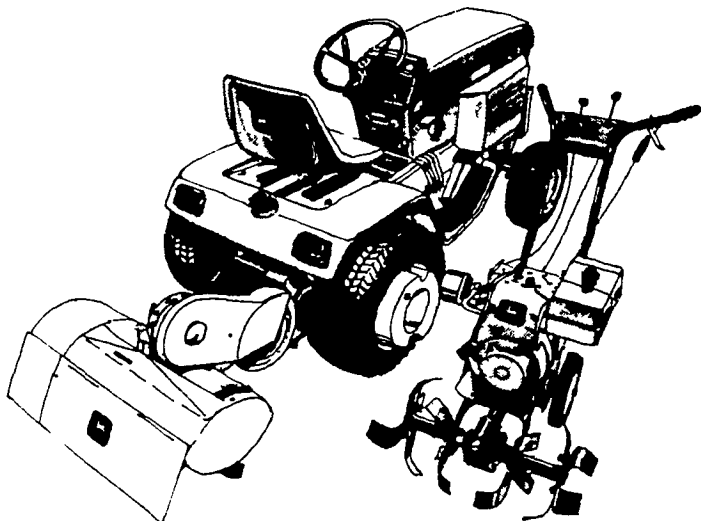

With the rising cost of food, what better way to fight inflation than to grow your own vegetables? John Deere can provide the equipment to make it easier.

Two models of John Deere Walk-Behind Tillers are available. The 2-hp compact tills a swath 16 inches wide and up to 7½ inches deep. The heavy-duty 6-hp model has a 13- to 24-inch tilling width and a tilling depth of 7 inches. The compact tiller has a lock handle with full-width control bar that lets you operate the machine from behind or from either

side. A unique rear-wheel/depth bar assembly swings down for transport, up for tilling. The heavy-duty model has a reverse gear and a pressure activated clutch for added safety.

John Deere Lawn and Garden Tractors pack the muscle you need for even tougher gardening chores. Choose a model, 10 to 19.9 horsepower, then add a capacity-matched tiller that tills 22 to 48 inches wide.

Stop in soon. And let us help you fight inflation with John Deere gardening equipment.