

REDUCE FEED COSTS WITH A TIME SAVING-MONEY MAKING GRINDER-MIXER FROM SPERRY NEW HOLLAND

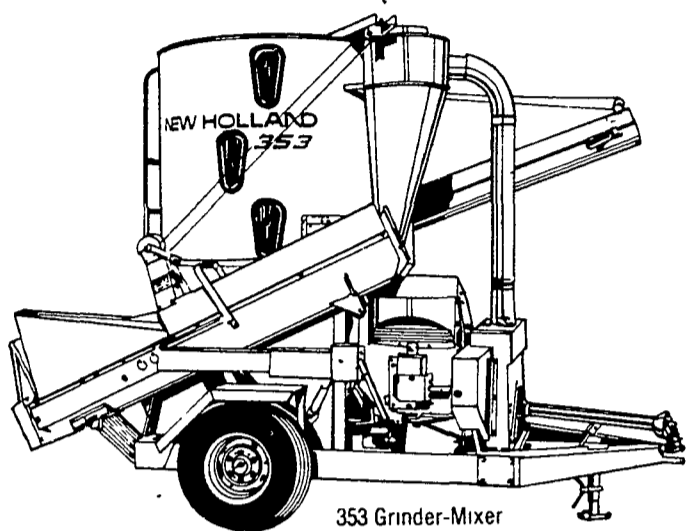

353 Grinder-Mixer

- 80-BUSHEL TANK, 16-INCH MILL
- 10, 13, 17 or 20 Ft. UNLOADING AUGER
- OPTIONAL ELECTRONIC SCALE
- MECHANICAL DRIVE

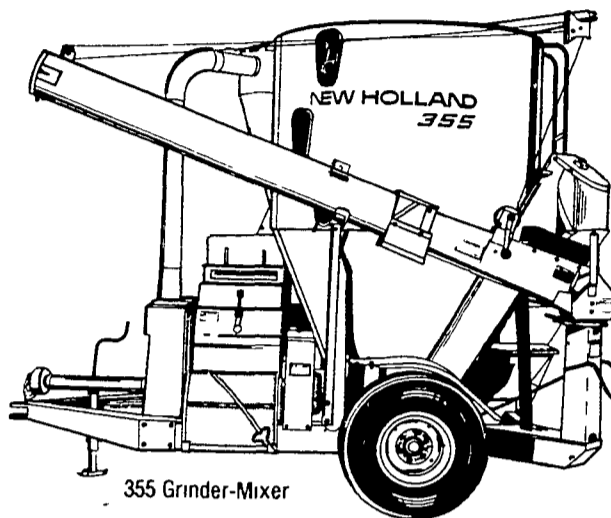

355 Grinder-Mixer

- 100-BUSHEL TANK, 21-INCH MILL
- 10, 13, 17 or 20 Ft. UNLOADING AUGER
- OPTIONAL ELECTRONIC SCALE
- MECHANICAL OR HYDRAULIC DRIVE



CONVENIENCE...IT GIVES YOU COMPLETE CONTROL OVER THE RATION - WHEN AND WHERE YOU NEED IT.

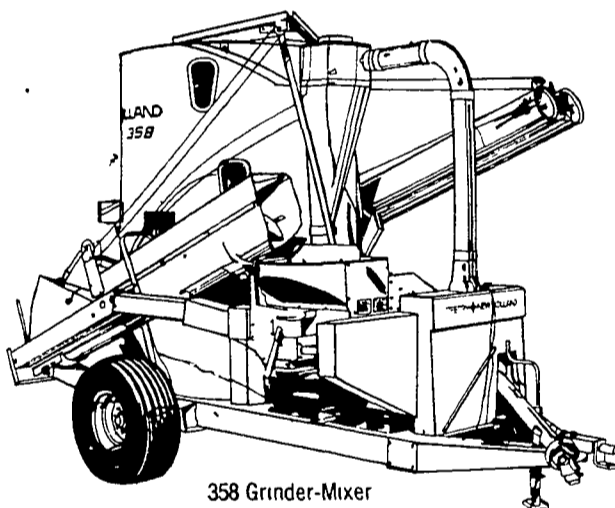

358 Grinder-Mixer

- 125-BUSHEL TANK, 21-INCH MILL
- 10, 13, 17 or 20 Ft. UNLOADING AUGER
- OPTIONAL ELECTRONIC SCALE
- MECHANICAL OR HYDRAULIC DRIVE



GOOD QUALITY FEED... YOU'LL HAVE COMPLETE CONTROL OVER WHAT GOES INTO YOUR RATION.

NEED EXTRA LARGE GRINDING CAPACITY? CHECK OUT OUR MODEL 359 GRINDER MIXER WITH A 25 INCH MILL AND 150 BU. TANK. BUY NOW - NO FINANCE CHARGES UNTIL APRIL 1, 1981!



FUEL UP - ON US! ASK YOUR DEALER HOW YOU CAN EARN A CERTIFICATE WORTH UP TO \$3,500 TOWARD FUEL PURCHASES WHEN YOU BUY SELECTED SPERRY NEW HOLLAND HAY AND FORAGE HARVESTING TOOLS PLUS COMBINES.



ASK THESE DEALERS HOW YOU CAN

UTILIZE YOUR HOME-GROWN GRAIN TO BEAT THE HIGH COST OF COMMERCIAL RATIIONS.



Your authorized **SPERRY NEW HOLLAND** dealer