

HOMELITE®

Homelite® Centrifugal Pumps

1 EP 215-1 One of two new self priming agricultural pumps • Pump body impeller and volute made of corrosion-resistant thermoplastic • Handles liquid fertilizers herbicides pesticides and other salt and alkaline solutions which normally damage conventional aluminum and cast iron pumps • Engine replaced by a pedestal and drive shaft assembly allowing choice of driving power source • Output capacity is variable up to 6 000 g p h through a 1½" suction discharge • Total head up to 110 • Carbon-ceramic shaft seals with stainless steel and Buna N rubber* parts • Weight - 10 lbs (pump only)

2 EP 220-1 This model also gives you a choice of driving power source such as electric motor or PTO shafts • Variable output capacity up to 9 600 g p h with a 2" suction discharge • Rugged injection molded thermoplastic pump body impeller and volute easily handles herbicides pesticides and other salt and alkaline solutions • Self priming design has built in check valve to provide quick repriming after pump shutdown • Disassembles with a screwdriver • Shaft seals have stainless steel and Buna N rubber* parts • Total head up to 110 • Weight - 10 lbs (pump only)

3 AP 215-1 Rugged thermoplastic pumps are ideal for farm and industrial use designed to pump liquid fertilizers herbicides pesticides and other salt and alkaline solutions • High output capacity of 6 000 g p h through a 1½" suction discharge • Four cycle single cylinder engine develops 3 h p • Automatic rewind starter • Magneto ignition for fast starts • Pump impeller volute and body reinforced polyester thermoplastic to resist internal corrosion • Self priming design uses built in check valve and carbon ceramic shaft seals with stainless steel and Buna-N rubber* parts • Weight - 32 lbs

4 AP 220-1 Economical to operate and maintain with an output capacity of 8 400 g p h with a 2" suction discharge ideal for pumping liquid fertilizers and pesticides • Pump body impeller and volute are reinforced polyester thermoplastic to resist corrosion • Fast self priming design with check valve gives a 5 ft suction lift • Total head up to 94 ft • Carbon ceramic shaft seals made of stainless steel and Buna N rubber* • Powered by a 4 cycle single cylinder engine with splash type lubrication • High voltage magneto ignition system • Washable foam air cleaner • Weight - 32 lbs

AGRICULTURAL PUMPS



1 EP 215-1

SALE
\$119⁰⁰
List \$189.00



2 EP 220-1

SALE
\$129⁰⁰
List \$198.00

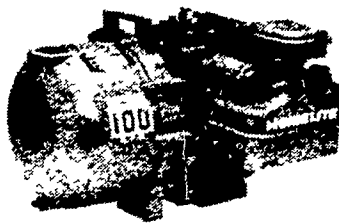

3 AP 215-1

SALE
\$179⁰⁰
List \$249.00

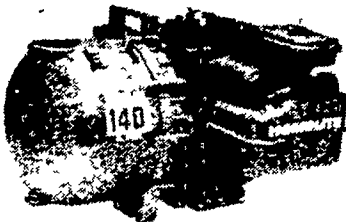

4 AP 220-1

SALE
\$199⁰⁰
List \$274.00

IN STOCK ITEMS ONLY

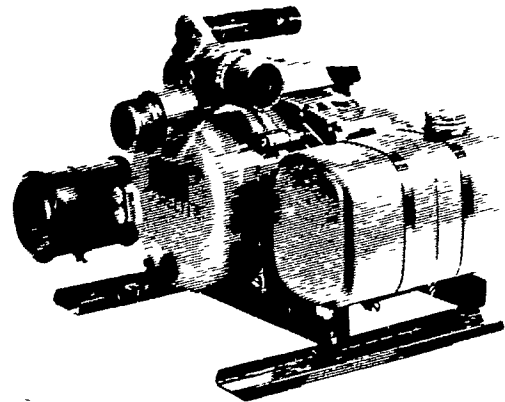

Model XLS1½ (1½")

- | | | |
|----------------------------------|----------------------------------|--|
| Pump | • Cast aluminum pump end | • Suction/discharge nipples and metal strainer |
| • Self priming design | • Cast iron open 3-vane impeller | • Steel wear plate |
| • Cast iron open 3-vane impeller | • Vibration-isolated skids | Engine |
| • Rubber-cushioned carry handle | | • Air cooled Homelite* 2 cycle engine |
| | | • Diaphragm type carburetor |
| | | • Automatic recoil starter |

SALE **\$329⁰⁰**
List \$479.00

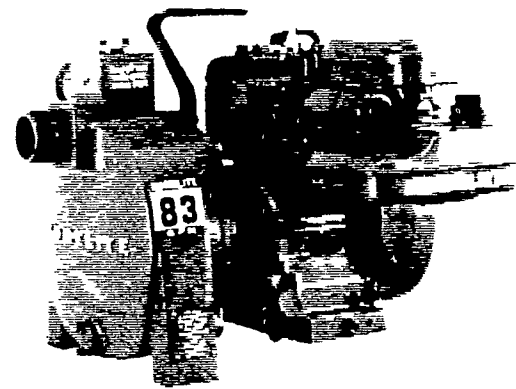

Model 110SU1½ (1½")

- | | | |
|-----------------------------|--------------------------------------|------------------------------|
| Pump | • Cast aluminum pump housing | • Carry handle |
| • Cast iron 3-vane impeller | • Self priming design | • Steel wear plate |
| • Suction/discharge nipples | • Corrosion resistant metal strainer | • Cast iron impeller housing |
| | | Engine |
| | | • 2 hp 4-cycle engine |
| | | • Automatic recoil starter |

SALE **\$299⁰⁰**
List \$389.00

GENERATORS

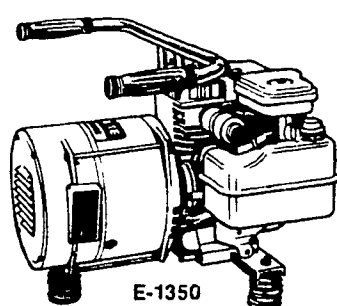

E-1350

SALE
\$329.00
List \$465.00

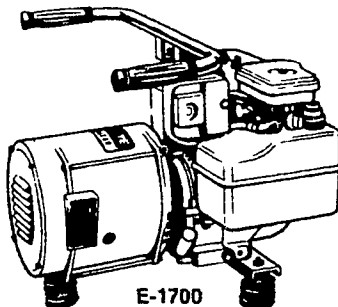

E-1700

SALE
\$399.00
List \$545.00

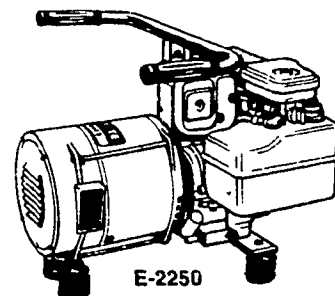

E-2250

SALE
\$499.00
List \$655.00

EMERGENCY STANDBY POWER FOR THE HOMEOWNER

Run Your Furnace, Freezer, Refrigerator, Lights, TV

Bombergers

Monday, Thursday, Friday 'til 9:30 • Tuesday, Wednesday, Saturday 'til 6:00

ELM, PA
(717) 665-2407

WE SERVICE

SALE ON STOCK ITEMS ONLY