

# GET YOUR WINTER CHORES DONE FASTER WITH TIME SAVING-MONEY

## MAKING TOOLS BY SPERRY NEW HOLLAND...

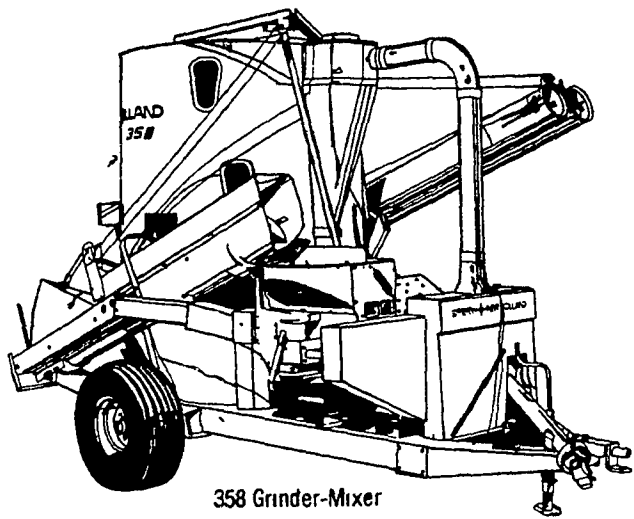

358 Grinder-Mixer

GET THE JOB DONE FASTER WITH MILLS UP TO 25" WIDE AND TANKS WITH UP TO 150 BUSHEL MIXING CAPACITY.

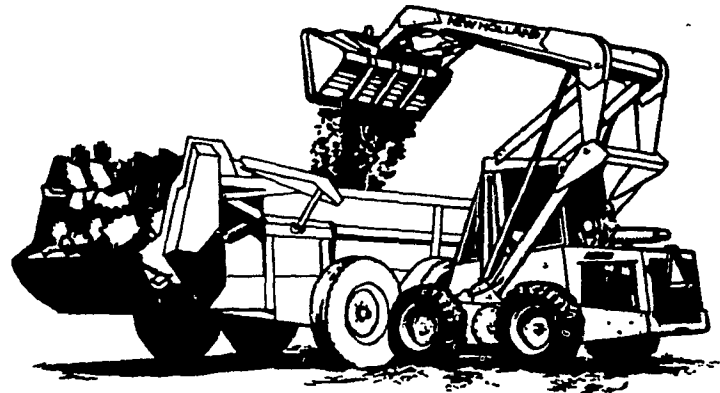

LET A "SUPER BOOM" LOADER DO YOUR TOUGH CLEAN-UP JOBS FAST! LOAD INTO THE CENTER OF BIG TANDEM-AXLE SPREADERS. CHOICE OF SIX MODELS.

### THE STRONG-BOXES

Built Extra Rugged For Extra Dependability.

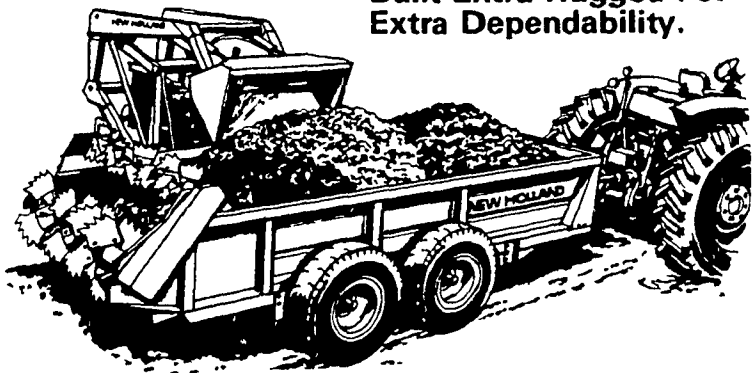

HAUL UP TO 14 TONS PER LOAD WITH A DEPENDABLE BOX-TYPE SPREADER YOU CAN "CUSTOMIZE" WITH OPTIONAL ATTACHMENTS.



After the sale...  
it's the service that counts!

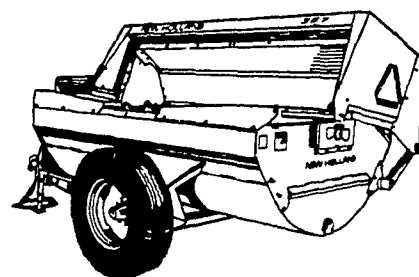

Keep your barn area tidy,  
the roadway clean  
and your neighbors happy!

Here's the spreader we'll stand behind! No drip! No trail! Plus, Sperry New Holland spreaders have a solid warranty

- Liquid-tight steel tank!
- All-weather operation!
- 593 to 1,421 gallons!

SEE YOUR NEW HOLLAND DEALER LISTED ON THE OPPOSITE PAGE FOR "TIME SAVING - MONEY MAKING" TOOLS THAT ARE JUST RIGHT FOR YOUR FARM. WHILE YOU'RE THERE ASK HIM HOW YOU CAN GET A CHECK FROM SPERRY NEW HOLLAND DURING DOLLAR DIVIDEND DAYS!

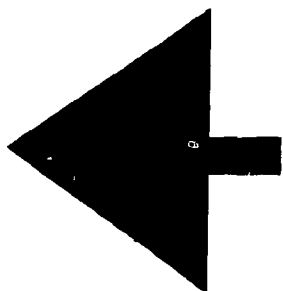

Your authorized SPERRY-NEW HOLLAND dealer