

4-H'er wins nutrition award

NEWARK, Del — For Seaford teenage Tami Jane Gundry, eight years of fun and fellowship in 4-H have paid off in a big way. Tami has been named a national 4-H award winner and recipient of a \$1000 scholarship at the National 4-H Congress in Chicago Nov. 29-Dec. 4, where the

awards were announced. Tami is one of four national winners from Delaware, all chosen by the Cooperative Extension Service on the basis of their accomplishments in 4-H project work, leadership and citizenship. The 17-year-old high school senior is the daughter

of Blanche and John Gundry, Route 3, Seaford. Her brother Tony, 14, is also active in 4-H, and her mother has been an assistant 4-H leader. Tami's award-winning activity was in foods and nutrition. As part of her project she conducted demonstrations on baking

for her club. She won the state contest in the foods category with a "red velvet" cake. An honor student with an aptitude for science and English, the poised and pretty brunette has also found time to become an expert baton twirler. She is captain of the Seaford High School majorettes, and frequently solos with the band. During her junior year she

was a delegate to the Governor's school for excellence, and was also awarded a scholarship to band camp. This year she was an alternate delegate to Girls' State. When the Gundrys are not involved in the operation of the family farm, they work together on a new house, a five-year project they hope to complete by Christmas. They are also active in the Seaford Methodist Church, where Tami is president of

the Methodist Youth Fellowship. After graduation in June, Tami hopes to spend a year abroad with the American Field Service in England, France or Spain. If she is not accepted in that program, she plans to enter West Virginia University to study medical technology. Tami's 4-H scholarship award and trip to Chicago was provided by General Foods Corp

A COUNTRY STORE FOR COUNTRY FOLKS

BALER TWINE

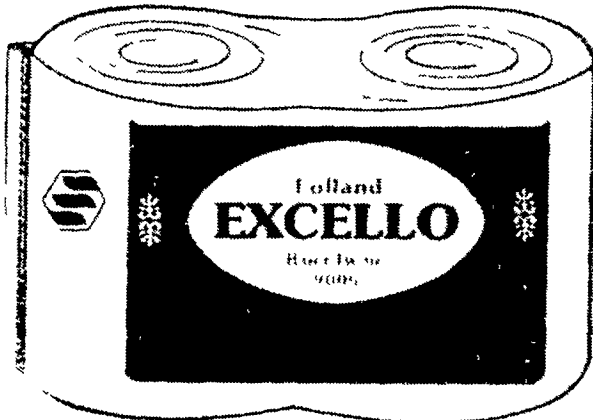

The World's Finest Twine
\$21.00 A Bale
 For 50 or more bales
\$21.25 A Bale
 For 10-50 Bales
 • 2 Rolls Per Bales
 Pay by Dec. 31, 1980

EXCELLO BALER TWINE
 Feet Per Bale 10,000 or 9,000
 Feet Per Pound 231
 Average Tensile Strength 350
 Gross Weight Per Bale 40 lbs.

Guarantee: All twine manufactured by Sisalana S A is guaranteed to work satisfactorily in any properly adjusted baler or binder. If by chance a ball should be found defective you may return it to your dealer and receive another ball in exchange.

BINDER TWINE

\$28.50 A Bale
 For 10-50 Bales
 • 6 rolls per bale
 • 26,000 Ft. per bale

QUAKER STATE DELUXE



10w-40
83c
 quart
 Reg. \$1.19
\$19.92 per case



Schauer
 LISTED
 6 AMP BATTERY CHARGER
 Reg. \$25.39
\$21.99
 • 6 Volt/12 Volt
 • Solid State
 • Automatic circuit breaker protected

	Reg.	SALE
10 amp	\$35.79	\$28.99
50 amp	44.89	\$39.99
100 amp	83.79	\$73.99
200 amp	111.99	\$94.99

HOMELITE CHAIN SAWS

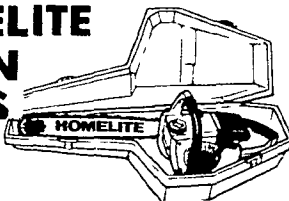

	Reg.	SALE
14" Super 2	\$169.99	\$144.99
16" VI Super 2	\$219.99	\$167.99
16" 150	\$229.95	\$187.99
16" Super E2	\$269.95	\$209.99

WE RENT LOG SPLITTERS -
 3 Pt. Hitch & Trailer Type
\$25.00 day

PORTABLE OIL HEATERS REDDY HEATER

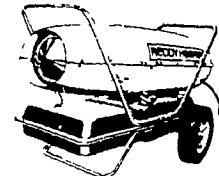

	Reg.	SALE
30,600	149.95	\$129.95
50,000	169.95	\$149.95
100,000	265.95	\$229.95
150,000	329.95	\$289.95
350,000	799.95	\$699.95
Thermostat	32.95	\$29.00

LIGHTS OUT?

PEACE OF MIND IS A HOMELITE GENERATOR

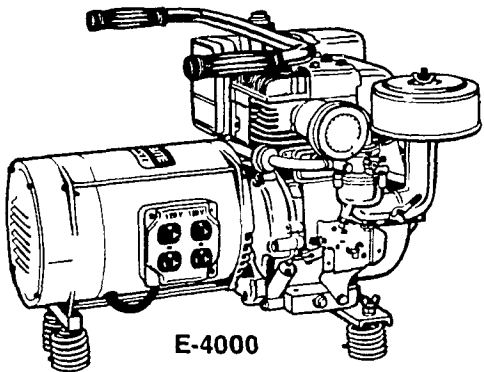

SAVE \$116.00

Watt	Reg.	SALE
1350	\$405.00	\$289.00
1700	\$439.00	\$339.00
2250	\$479.00	\$399.00
3000	\$589.00	\$469.00
4000	\$789.00	\$689.00



FLANNEL SHIRTS
\$9.99

BIG SMITH JEANS
\$9.99
 Reg. \$11.49

DESIGNER JEANS . \$15.99

FULL LINE OF FARM TOYS ERTL & TONKA

Reg. \$20.99
 NOW **\$17.99**

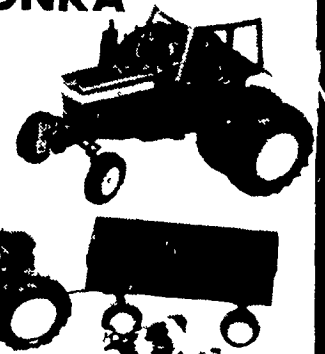

Reg. \$9.49 NOW **\$7.99**

JUST ARRIVED

Box type DOOR TRACK

8' - 18' Sections with all the accessories

- 16 gauge trolley rail
- adjustable trolley roller hangers

(400 lb. Door)

K.E.W. HI PRESSURE WATER CLEANER

PSI	List Price	OUR SALE PRICE
2200	\$2190.00	\$1879.95
1300	\$1715.00	\$1495.00
500	\$399.99	\$349.99

You Can Rent the 2200 or 1300 PSI for **\$30.00** one day



\$3.49 gal.
 Bring Your Own container

STOP pipe freezing

New **FROSTEX II** Heating Cable

\$1.35 Ft
 safer won't overheat even when overlapped use on any pipe even plastic
 more reliable new design for long life regulates its own heat output without a thermostat cut it to any length

WE UPS ANYWHERE - JUST CALL 717-464-3321
 SALE PRICES GOOD THROUGH DECEMBER 20

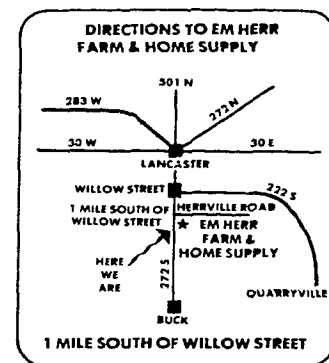

Store Hours
 Mon Thurs 7:30 A M - 6:00 P M
 Sat 7:30 A M - 5:00 P M
 Fri 7:30-9:00

EMHERR FARM & HOME SUPPLY
 R.D. 1, Rte. 272 South, Herrville Rd.
 Willow Street, Pa.
 Phone: (717) 464-3321

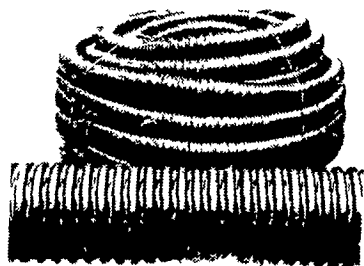

ADS
 ADVANCED DRAINAGE SYSTEMS INC.

4" Solid or Perforated
 6" Solid or Perforated

FIELD DRAIN PIPE
25c Ft
58c Ft