

THE GRINDER-MIXER YOU NEED IS HERE!

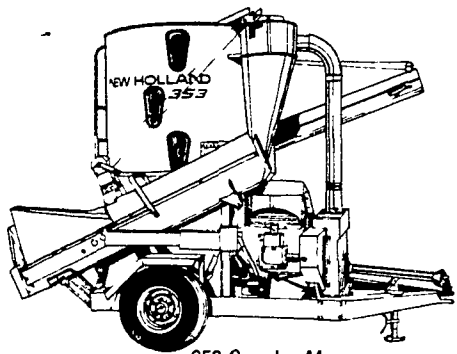

353 Grinder-Mixer
80 Bu. Tank with 16" Mill

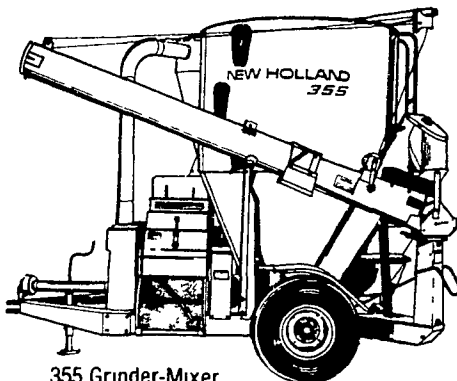

355 Grinder-Mixer
100 Bu. Tank with 21" Mill

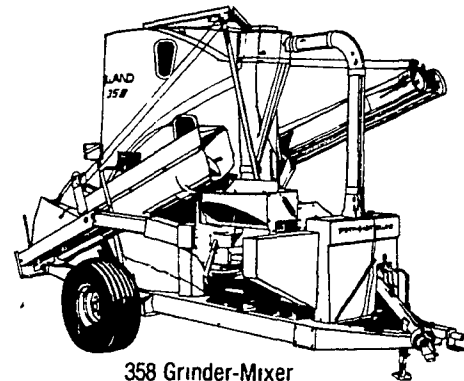

358 Grinder-Mixer
125 Bu. Tank with 21" Mill

BIG, 8-INCH DIAMETER UNLOADING AUGERS UP TO 20-FOOT LENGTHS THAT FOLD BACK TO 10 OR 12 FEET FOR EASY TRANSPORT AND STORAGE.

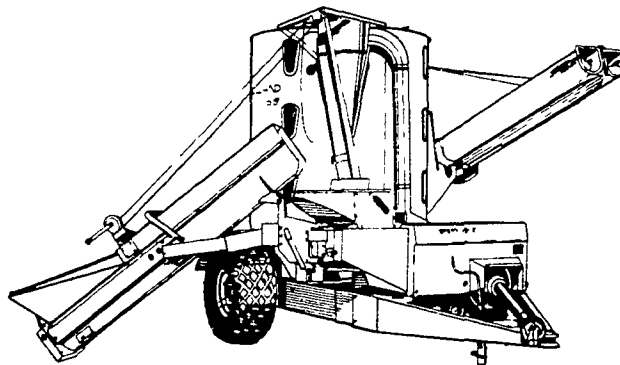

359 Grinder-Mixer
150 Bu. Tank with 25" Mill

ALL FOUR MODELS CAN BE EQUIPPED WITH OPTIONAL ELECTRONIC SCALE. OPTIONAL HYDRAULIC DRIVE AVAILABLE ON THREE MODELS.

WHILE CHECKING OUT THE COUNTRY'S LONGEST LINE OF GRINDER-MIXERS, ASK ABOUT OUR END-OF-SEASON SPECIALS ON SELECTED EQUIPMENT. WE'RE CELEBRATING DOLLAR DIVIDEND DAYS.

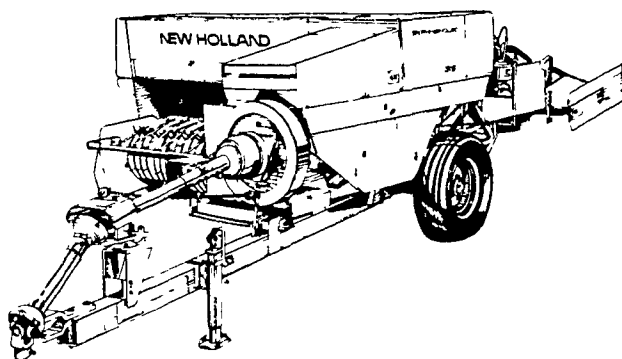

315 Baler

SAVE UP TO \$2,500 ON PURCHASES DURING DECEMBER!

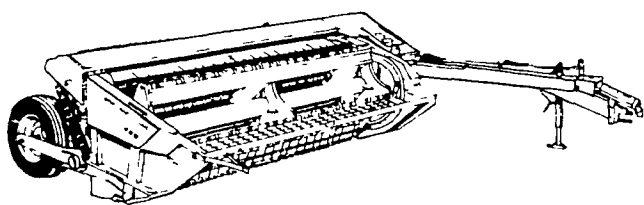

489 Mower-Conditioner

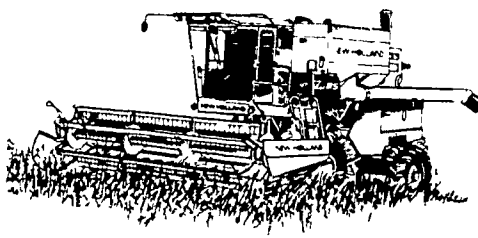

TR-85 Twin Rotor™ Combine

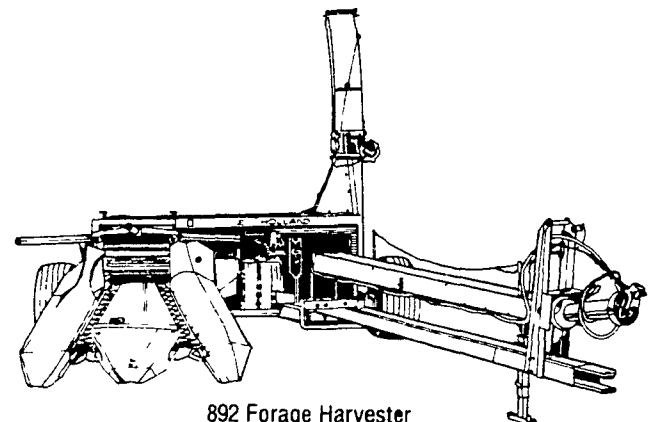

892 Forage Harvester

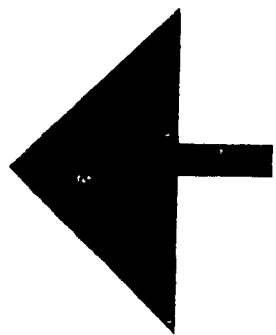

VISIT YOUR NEARBY SPERRY NEW HOLLAND DEALER LISTED ON THE OPPOSITE PAGE FOR DETAILS!

SAY QUALITY - SAY VALUE - SAY SPERRY NEW HOLLAND

