

York Farm Credit holds annual meeting



York Farm Credit manager Richard Zook thanked members for their continuing support during his annual report to the lending cooperative's meeting.

CARLISLE — Over 800 members and guests of the York Farm Credit Association jammed the elegant ballroom at the Embers Restaurant for the cooperative's annual dinner meeting last Thursday evening.

H Richard Zook, manager of the York Federal Land and associate manager of Production Credit Association, told the members, "We have never before experienced a time when the money markets have fluctuated like they have during the last year and a half."

"Interest rates through the Land Bank system climbed steadily from a nine and a half percent level in June, 1979, to 12 percent in

May, 1980, and then dropped a percent in July.

Production Credit's rates rose from 13 percent in January to 15 percent in April and then fell back to 12 percent in August.

Zook said the Farm Credit system realizes the need to provide prompt and sufficient credit to the farming industry, and will make every effort to supply that need to insure adequate food supplies for the nation.

As of September 30, 1980, the York PCA was handling loans for 920 members, with a loan volume of over \$31 million, a lending increase of 11 percent with five percent more members. A 6 percent dividend from PCA was paid to stockholders last December in the amount of \$11,570.70.

At the end of this year's third quarter, the Federal Land Bank was servicing 1312 members, with loans of over \$77 million. The York Land Bank's volume is up 22 percent in lending and over 16 percent in membership.

Within the past year, the Association has opened a full-time branch office in Perry County, staffed by loan officer Ronald Moore and office assistant Deloris Sutch.

Three Farm Credit directors were re-elected to the board for three-year terms: Maynard Weary, Newville R1, the current president of the Land Bank board, was returned to the board, as well as PCA

(Turn to Page B9)



Three directors were re-elected to the York Farm Credit's board. From left are Maynard Weary, Marlin Miller and Norman Blocher.

NO. 1 DAIRYING DIESEL

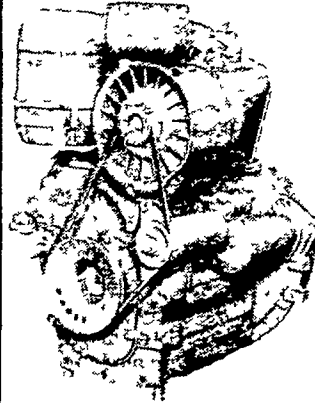

Since 1968 F2L-912 diesels have earned the reputation as the most reliable diesel. Don't settle for less.

2 Cyl F2L-912 (New Style)

EASIER STARTING: Heavy flywheel provides easy starting. No electric heater plugs.

QUIETER: Runs quieter than most water cooled diesels. Very quiet exhaust.

F2L-912 SPECS: 22 Hp @ 1500 RPM
27 Hp @ 1800 RPM
34 Hp @ 2300 RPM

It has direct injection, lube oil cooling, and oil cooled pistons. This engine has proven to survive the extreme heat of a heavy load in a small engine house better than any other engine.

PLUS - FAMOUS DEUTZ FUEL ECONOMY

**ASK ABOUT STAUFFER'S
5-YEAR ENGINE HEAD
& BLOCK WARRANTY**

Stauffer Diesel Inc.

312 W. Main St. New Holland, PA
Ph: 717-354-4181

HUSKY® LIQUID MANURE SPREADER

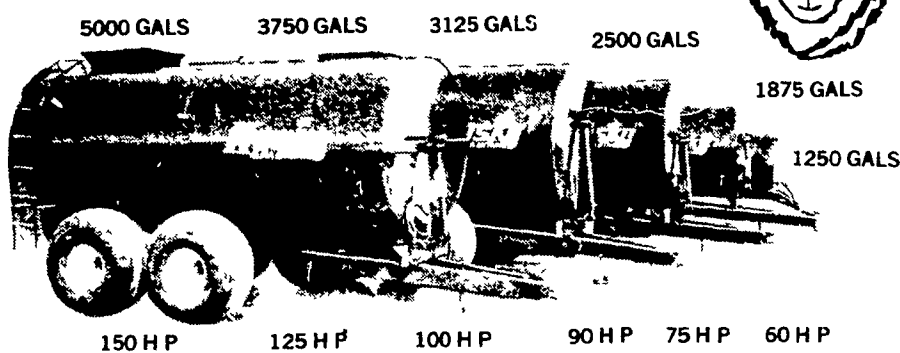

ASK ABOUT THE MANY ADVANTAGES LISTED BELOW

- Heavy duty tongue jack
- Full length auger inside for semi-liquid (optional)
- Corn row attachment to put manure between rows (optional)
- Cultivator attachment to work manure into the ground (optional)
- Hydraulic main drive (optional)
- Hydraulic Control Of Valve



WIDE SPREADING PATTERN

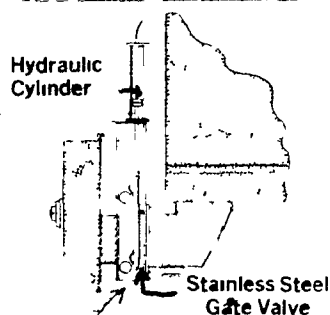

A false bottom for quick clean out of stones etc

LARGE 9" TANK DISCHARGE

• PLANNING LAYOUTS • SALES • INSTALLATION • SERVICE

SHENK'S FARM SERVICE

501 E. WOODS DRIVE, LITITZ, PA 17543

PHONE: 717-626-1151

Paul Repine - 717-626-2837 Mervin Nissley - 717-872-4565

Our Service Trucks Are Radio Dispatched • Bulk Tanks • Thermo•Stor
24 Hr. Service Offered

RED ROSE BUILDING SYSTEMS



P.O. Box 366
Manheim, Pa.

Call Collect
717-665-7150

**HOW TO GET
MAXIMUM
SPACE
AT
MINIMUM
COST...**

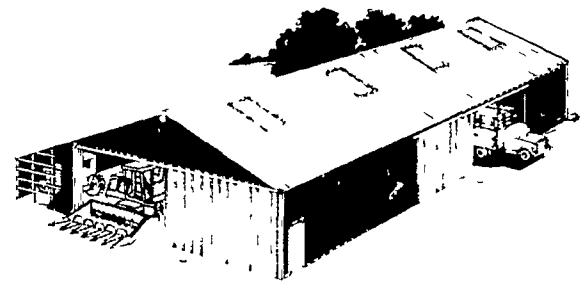

Red Rose EXTRA-WIDE SPANNERS. In terms of hard-cash savings, Off-Peak construction, offers you a great advantage. Full height, clear-span structure, plus a full length side bay can add close to 50% more floor storage per side. Yet costs less than half as much per square foot. Off-Peak buildings are an ideal solution for maximum room on a limited budget!

★ DO-IT-YOURSELFERS ★

Yes!

We Can Furnish You With A Complete Building Materials Package And Blueprints. Erect it yourself and Save Labor Costs!

Please contact me with information on the following:

- FARM BUILDINGS COMMERCIAL BUILDINGS
 DO-IT-YOURSELF BUILDING PACKAGES

Fill Out And Mail To: Red Rose Building Systems,
PO Box 366, Manheim, Pa. 17545

Name _____

Address or RD _____

Town _____ State _____ Zip _____

Phone (include area code) _____