

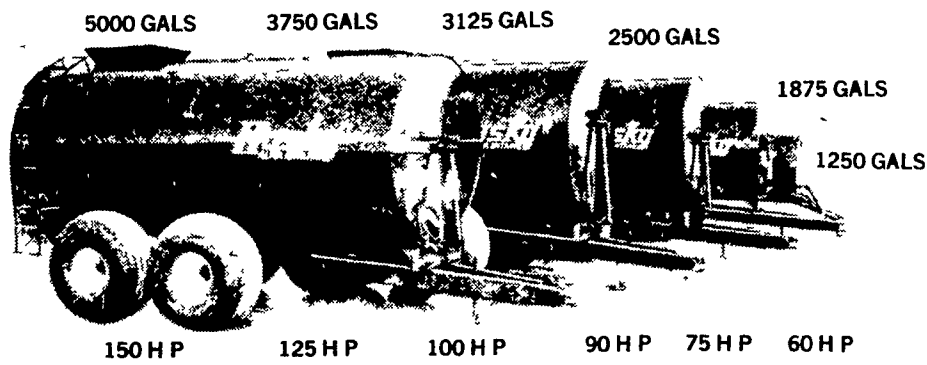

HUSKY[®] LIQUID MANURE EQUIPMENT

HUSKY LIQUID MANURE SPREADER

6 SIZES TO CHOOSE FROM



ASK ABOUT THE MANY ADVANTAGES LISTED BELOW

- Heavy duty tongue jack
- Full length auger inside for semi-liquid (optional)
- Corn row attachment to put manure between rows (optional)
- Cultivator attachment to work manure into the ground (optional)
- Hydraulic main drive (optional)
- Hydraulic Control Of Valve



WIDE SPREADING PATTERN

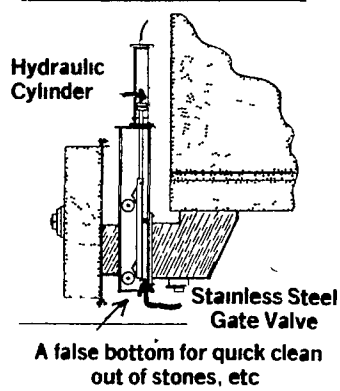

LARGE 9" TANK DISCHARGE

H5000 PUMP • PUMP IT

Can be changed from "pumping" to "agitating" at full speed

NO OTHER MANURE PUMP OFFERS ALL THESE FEATURES

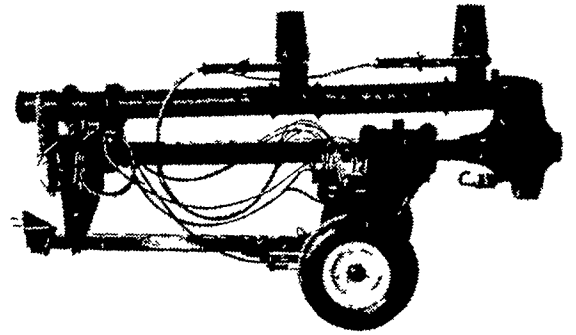

- 8" discharge
- Designed for 540 or 1000 rpm Simply turn gear box over
- Dual inlet
- Dual agitators - rotates 280°
- Curved impeller blades for greater hp efficiency
- Set up Fully Hydraulic pump can be installed in pit from tractor seat
- Can be changed from pumping to agitating at full speed
- Can rotate agitator spout hydraulically without disturbing filling spout
- Marine style rubber bearing has almost eliminated bearing wear
- Super heavy frame all bolted assembly for easy servicing
- Available for pits up to 12 ft deep

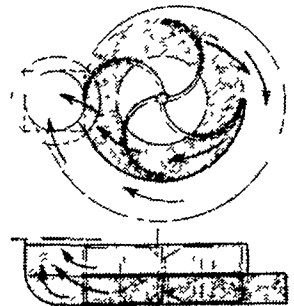

Manure enters in the top pump housing and in the bottom pump housing and has been designed so that the pressure on the propeller is equal With the inlet on top and bottom there is no side thrust on the bearings.

ASK US TO SEE A DEMONSTRATION

THE H5000 PUMP delivers to 5000 gallons per minute with 80 100 hp tractor designed for today's larger underground pits and hard to handle manure.

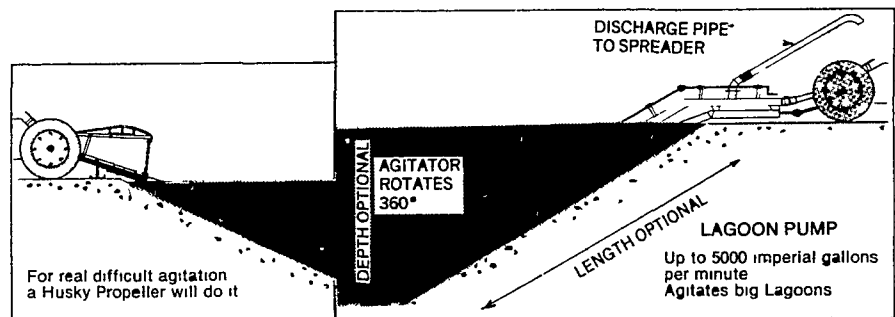

HUSKY[®] Model C72 2000 GPM - 65 HP

The HUSKY C72 has been well accepted for pumping and agitating - for cattle, poultry or hogs

Designed for 540 PTO speed with average size tractor freeing your larger tractor for hauling spreader

FEATURES

- Capacity up to 2500 gpm
- 5" discharge pipe 12 ft. long Quick disconnect flexible pipe rotates 360° for easy set up
- New "DILECTO" bearings water lubricated, acid resistant, long life
- Dual agitators
- Adapts to pits up to 12 ft. deep
- Heavy duty gearbox and PTO with shear pin
- Optional hydraulic cylinders to make set up easier

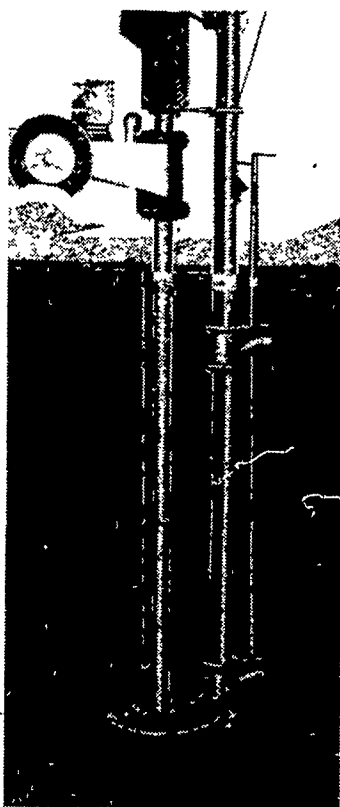

ACTION

HUSKY[®] side mounted AGITATOR PUMP

- High Capacity
- Simple construction
- Custom designed for above ground tanks - reasonable in price

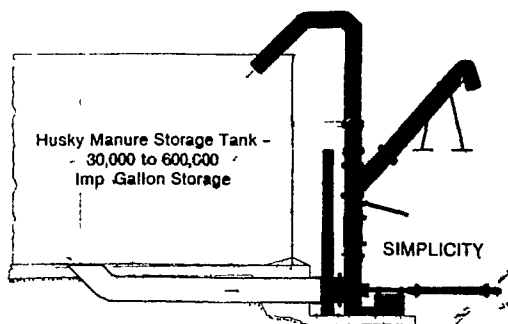

HUSKY[®] Model A TRANSPORT PUMP With 3 Point Hitch

Designed for 40 hp 1000 gpm.

Single agitator

For hog manure in tanks up to 50,000 gals

From 4 ft. to 12 ft. deep

This model has been on the market since 1965

A real economy model built for dependability

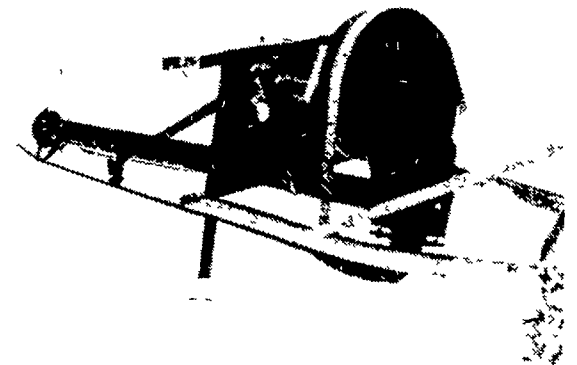

HUSKY[®] ELECTRIC YOUR IMAGINATION CAN ONLY DETERMINE THE USES FOR THIS PUMP

LOW PRICE!
TOPS IN SERVICE!

Used For:

- Filling above ground tanks
- Pumping out hog barns
- Filling flushing tanks
- Flushing gutters
- Pumping milk house waste
- Transfer manure or water from anywhere to anywhere

For 5 hp motor and up 3" discharge Up to 400 gpm Complete with agitator 'Fits in hole 15" x 21"

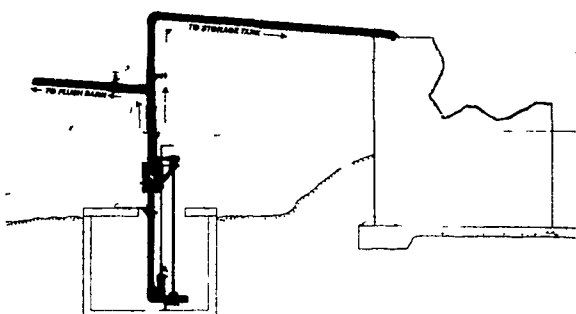

• PLANNING LAYOUTS • SALES • INSTALLATION • SERVICE SHENK'S FARM SERVICE

501 E. WOODS DRIVE, LITITZ, PA 17543

PHONE: 717-626-1151

Paul Repine - 717-626-2837

Mervin Nissley - 717-872-4565

Our Service Trucks Are Radio Dispatched • Bulk Tanks • Thermo•Stor 24 Hr. Service Offered

