

Chester County DHIA Monthly Report

September 1980
Chester County DHIA

Top herd for Fat in Chester County was Dunwood Farm with 2 18 pound fat per day.
Top herd for milk was George P Lamborn with 59 pound milk per cow per day.
Top cow for fat was Bessie with 1016 pounds. She is owned by Paul King.
Top cow for milk was Kornie with 28,077 pounds owned by John S Stoltzfus

OWNER	BREED	NO. COWS	% DAYS IN MILK	LBS. MILK	% FAT	LBS. FAT
Dunwood Farm	3	45 0	97 3	53 1	4 1	2 18
George P. Lamborn	3	38 0	94.3	59 0	3 4	2 00
Melvin Stoltzfus	3	40 6	84.6	49 5	4 0	1 97
Merle J King	B3	80 9	90.8	52 6	3 7	1 92
H & R Mason	3	99 4	83 5	49 6	3 8	1 87
John S Stoltzfus	3	68 0	84 0	49 9	3 7	1 86
D & T Kauffman	3	29 1	89 8	55 1	3 4	1 86
Ardrossan Farms	1	118 8	84 1	47 7	3 9	1 85
D Hostetter Jr	3	78 0	85 5	52 6	3 5	1 85
J Elmer Lapp	3	37 4	96 5	52 2	3 5	1 84
Lene Hill Farms	B3	50 6	89 2	51 7	3 6	1 84
Jonas B Stoltzfus	3	41 9	87 8	52 0	3 5	1 83
Christ Stoltzfus	3	51 1	87 3	53 3	3 4	1 82
David Windle	B3	41 7	88 5	47 9	3 7	1 79
Walmoore #2	B3	140 2	89 8	51 0	3 5	1 77
Jonas Z King	B3	33 2	86 8	50 1	3 5	1 77
J. Kenneth Landis	B3	50 4	93 9	49 4	3 5	1 75
Joseph S. King	B3	83 8	92 0	49 1	3 5	1 74
Round Top Farm	B3	72 0	86 1	48 6	3 6	1 74
Louis C Neyman	G3	35 0	90 4	45 6	3 8	1 72
Jay E. Graybill	B3	70 1	80 0	50 2	3 4	1 72
Newton Evans Jr	3	77 6	88 7	49 7	3 4	1 71
John M Umble	3	47 0	78 8	45 9	3 7	1 70
Walmoore #3	B3	137 1	89 2	48 3	3 5	1 70

John R Groff	B3	52 3	96 1	41 4	4 1	1 70
Paul King	3	68 6	86 8	45 1	3 7	1 68
Kulp Bros	G3	90 0	87 1	43 6	3 9	1 68
H Freese & Son	3	67 5	84 0	44 4	3 8	1 68
Floyd Miller	B3	54 6	87 6	42 5	3 9	1 67
Arthur D Hershey	3	54 6	96 5	47 1	3 5	1 66
David Stoltzfus	B3	39 6	85 9	45 2	3 7	1 65
Mast Stoltzfus	B3	54 4	85 2	45 2	3 6	1 64
D Hostetter Jr	3	52 0	86 0	45 5	3 6	1 64
Simon Z. Zook	G3	42 0	81 7	44 5	3 7	1 63
Harvey C. Waltz	B3	82 7	92 5	46 2	3 5	1 62
R. Proud & Son	B3	57 0	81 8	43 5	3 7	1 62
Hargret Dairy	B3	51 2	87 0	43 9	3 7	1 62
J R Harnish	B3	78 3	86 8	47 3	3 4	1 61
James V Yale	B3	59 0	87 2	45 9	3 5	1 61
Herman Stoltzfus	3	45 1	86 3	47 6	3 4	1 60
David E Weaver	3	83 4	76 0	42 8	3 7	1 59
V Guest & Son	B3	82 9	79 3	44 9	3 5	1 58
Marsh Acres Farm	B3	91 0	90 7	43 6	3 6	1 57
Ronald F Elliott	B3	62 7	88 7	38 3	4 1	1 56
Lloyd Mast & Sons	3	108 5	91 8	43 0	3 6	1 56
J Dean Cheek Jr	B3	45 2	87 8	43 5	3 6	1 56
Timothy Kauffman	3	39 3	86 8	42 7	3 6	1 55
Daniel Stoltzfus	B3	43 4	92 9	39 9	3 9	1 55
Elmer A Mast	B8	66 2	81 6	39 6	3 9	1 54
E Kent High	B3	131 0	97 0	44 5	3 5	1 54
Applebrook Guern	2	57 7	90 8	33 7	4 5	1 53
Kauffman Bros	3	62 0	90 9	43 7	3 5	1 53
Moran & Nickle	B3	77 6	83 5	41 9	3 7	1 53
Eli K Stoltzfus	B3	39 9	87 1	41 8	3 7	1 53
Calvin R Blank	B3	56 2	81 8	44 2	3 5	1 53
Earl Mast	3	33 4	82 1	45 1	3 4	1 52
B K Kauffman	3	40 4	89 1	38 1	4 0	1 52
Harold J Ranck	3	50 2	88 1	42 3	3 6	1 52
David L Weaver	B3	43 8	83 5	47 8	3 2	1 52
Charles H Gable	1	55 1	81 4	35 9	4 2	1 50
David Walton	3	45 6	85 1	42 3	3 5	1 50
Robert W Campbell	1	37 9	91 8	37 7	4 0	1 50

OWNER NAME OR NUMBER	DAYS IN MILK	LBS. MILK	% FAT	LBS. FAT	
Paul King	3	305	26,955	3 8	1016
Bessie	3	305	25,869	3 5	899
Snitzer	3	305	29,438	3 9	861
Roma	3	305	24,738	3 5	861
Bell	3	305	24,621	3 2	789
Rocky	3	305	20,982	3 6	764
Dusty	3	305	21,047	3 4	713
Jennie	3	305	21,047	3 4	713
Christ L Stoltzfus	3	305	20,078	4 8	973
Hopeful	3	305	23,448	3 9	909
Queen	3	300	21,360	4 0	858
Polly	3	264	21,870	3 7	816
Lucy	3	305	24,100	4 0	964

Lancaster Farming, Saturday, October 18, 1980—B11

Laura	3	305	25,894	3 3	848
Helen	3	305	20,035	4 1	821
Elmer A Mast	3	305	25,721	3 7	956
Ella	3	305	18,656	4 6	855
Hannan	3	305	21,267	3 7	793
Louise	3	282	17,457	4 4	770
Willie	3	300	21,445	3 5	757
Annie	3	305	14,990	4 9	740
Topsy	2	292	20,795	3 5	728
W. Flowr	3	305	19,254	3 8	727
Anita	3	305	20,388	4 5	927
Hargret Dairy Inc	3	296	18,606	4 4	816
54	3	305	20,499	4 5	924
John M Umble	3	305	21,945	4 2	920
Cream	3	305	20,523	4 1	837
Wimpy	3	305	19,260	4 2	809
Sue	3	283	19,444	3 8	743
Sybal	3	305	21,837	4 2	914
Sadie	3	305	20,105	4 3	857
Merle J King	3	305	22,838	3 6	832
Fifi	3	305	19,854	3 9	781
Evie	3	305	24,236	3 7	902
Connie	3	288	20,235	3 7	748
Rhonda	3	305	28,077	3 2	887
David E Weaver	3	305	20,744	4 0	837
Blacky	3	305	18,802	4 4	818
Pokadot	3	280	16,987	4 6	776
John S Stoltzfus	3	305	20,506	4 3	886
Kornie	3	305	25,202	3 5	885
Dust	3	305	20,412	4 3	883
Piper	3	305	24,509	3 6	877
Sherry	3	305	23,621	3 7	871
Gideon Stoltzfus, Jr	3	305	23,960	3 5	840
Lynn	3	290	20,099	4 0	809
H & R Mason	3	305	23,542	3 4	794
87B	3	305	23,019	3 4	790
2G	3	305	20,827	3 8	784
84B	3	305	19,451	3 8	739
27K	3	305	24,108	3 6	879
78	3	305	22,006	3 9	869
33G	3	305	21,808	4 0	869
44M	3	305	20,697	4 0	823
97A	3	305	20,697	4 0	823
57A	3	305	20,697	4 0	823
76B	3	305	20,697	4 0	823
George P Lamborn	3	305	24,108	3 6	879
Melisa	3	305	22,006	3 9	869
Newton Evans Jr	3	305	21,808	4 0	869
29	3	305	20,697	4 0	823
Donald Hostetter Jr	3	305	21,808	4 0	869
Idla	3	305	20,697	4 0	823
Jessie	3	305	20,697	4 0	823

(Turn to Page B12)

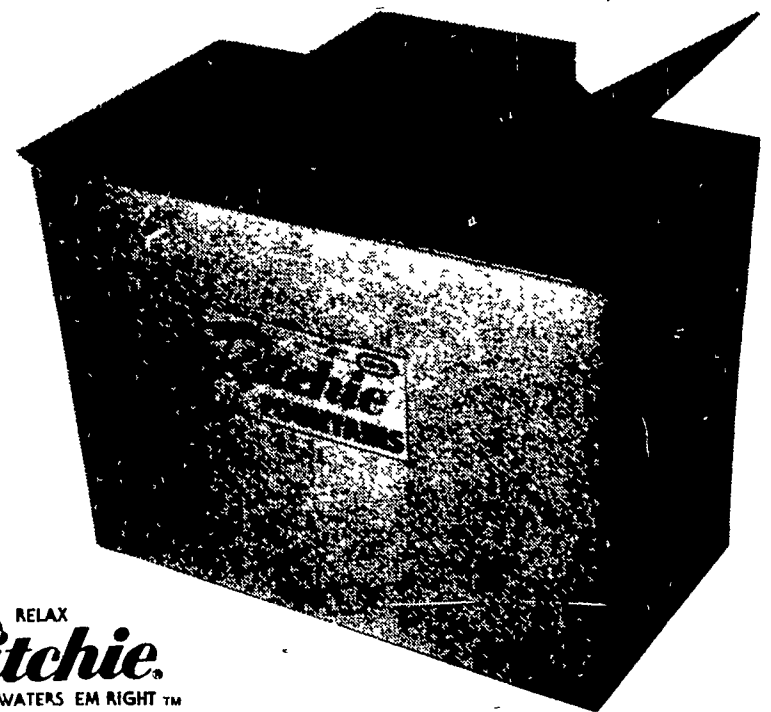

RELAX
Ritchie.
WATERS EM RIGHT™

WATER THAT WON'T QUIT

Ritchie Fountains deliver. Even in the dead of winter they are out there working. You're not weatherproof. You bet they are. Heating systems and efficient insulation keep water ice-free. Just set the Watt Watcher™ thermostat for minimal energy use. Big-throated, non-stick plastic valves keep water gushing in. Each of your cows get all the water they need to promote peak production.

Ritchie Fountains are tough, too. Quality-built with rugged heavy galvanized steel and CD-50 epoxy finish to stand up to weather and barnlot abuse.

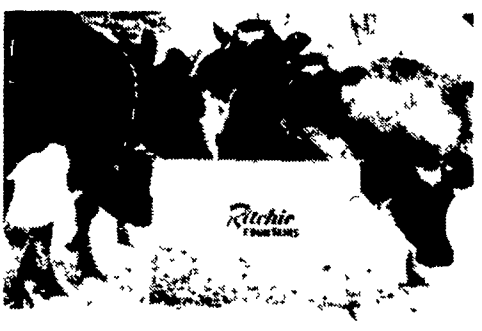

Why take chances on anything less than a red and yellow Ritchie Fountain? Call your Ritchie dealer for water that won't quit.

Automatic ELECTRIC FEED PROCESSOR

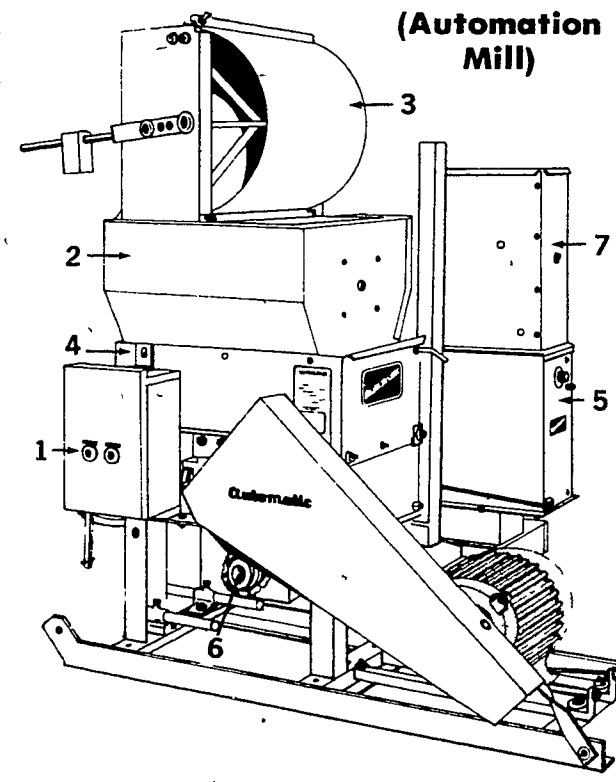

(Automation Mill)
Process and blend 3 or more ingredients at one time!

(1) Control center (Type III timer system) predetermines and records amount of feed grain. (2) Bin Switch regulates input auger, automatically controls grain level in hopper, (not visible). (3) Automatic scale meters preset amount of grain through roller mill, operates automatically and continuously without power. (4) Automatic Roller mill with fast roll attachment rolls grain. (5) Dial-controlled variable speed augers in electronic meter let you add protein, mineral or medication into mixing auger. (6) Mixing auger mixes and delivers processed feed to take-away auger. Supply auger and mill processed preset amount of grain. (7) Accessory hopper with flow switch.

Note: The Automatic Dump Scale and feed metering units may be gravity fed from overhead bins or hoppers. Flow-control switches are required if input augers are used in place of gravity flow.

EAR CORN UNIT

Automatic's ear corn unit handles wet, shucky and even frozen ear corn. The crusher unit shreds the cob followed by rollers that crack the corn, producing a flaky, dust-free feed for greater digestibility. The hydraulically driven intake auger swings to the rear for transport and may be operated at any angle from rear to side.

Dust-free rolled grain is more palatable, easier to digest, eliminates wheezing and many digestive disorders.

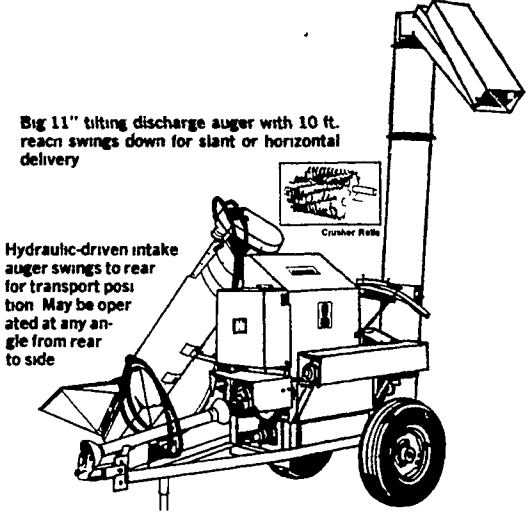

Big 11" tilting discharge auger with 10 ft. reach swings down for slant or horizontal delivery.

Hydraulic-driven intake auger swings to rear for transport position. May be operated at any angle from rear to side.

RYDER SUPPLY CO.

539 FALLING SPRING ROAD, P.O. BOX 219
CHAMBERSBURG, PENNSYLVANIA 17201
PHONE 717-263-9111