

SEE THESE MACHINES IN ACTION AT THE PENNSYLVANIA AG PROGRESS DAYS - AUG. 19-21

TOP OF THE 14" x 18" LINE

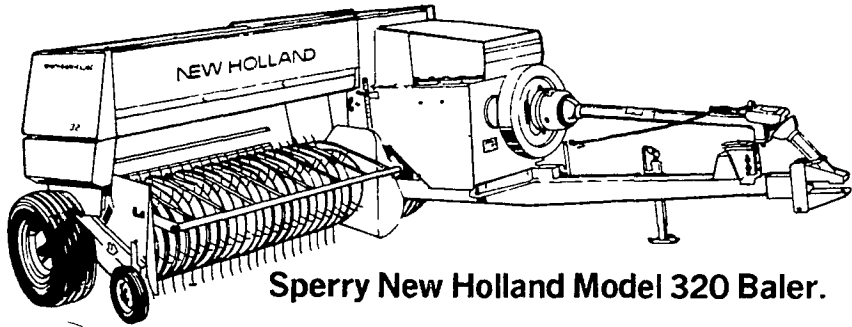

Sperry New Holland Model 320 Baler.

UNIQUE ROLAREEL HEADER 12' CUT AND 9' ROLLS

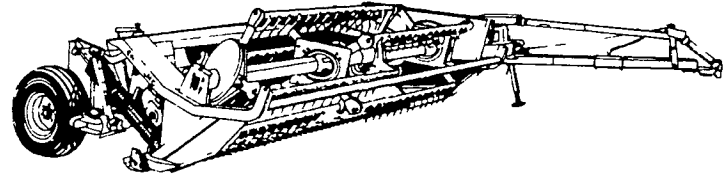

Model 495 Haybine Mower-Conditioner.

IT'S A ONE-MAN HAYING OPERATION

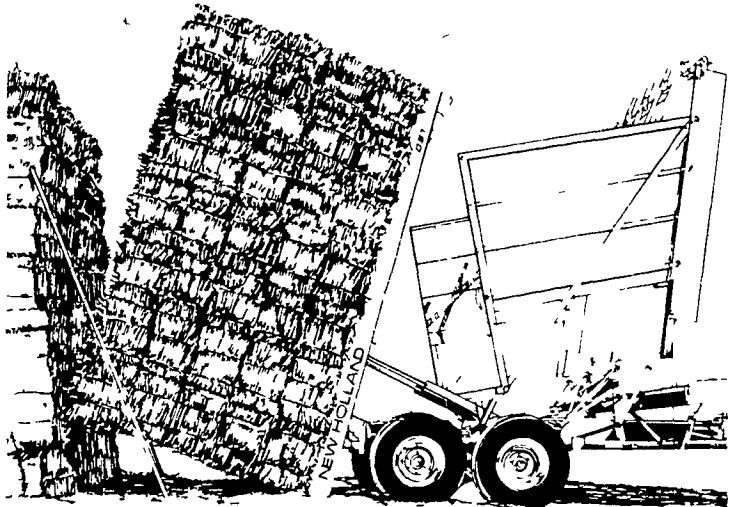

The Sperry New Holland Model 1037 Automatic Bale Wagon stacks three-wide for stability and hauls up to 4 tons per trip.

THE MOST AUTOMATED ROUND BALER YOU CAN BUY!

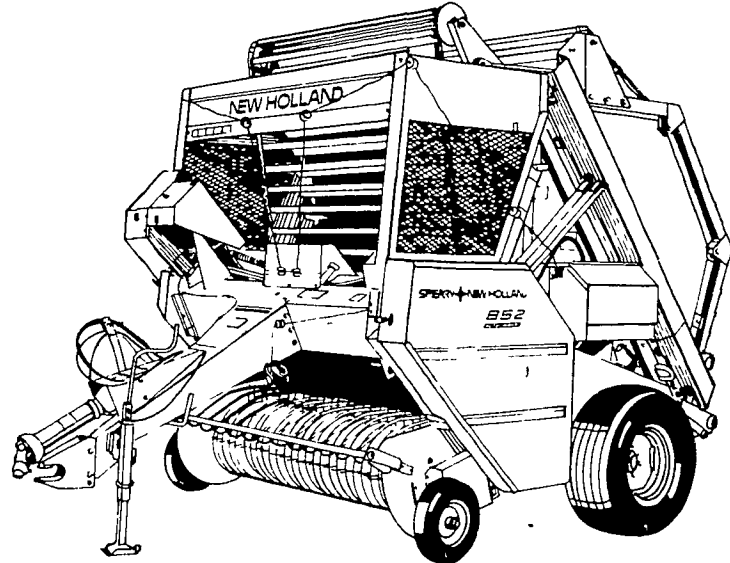

Model 852 Round Baler

OUR LARGEST CAPACITY PULL-TYPE CHOPPER

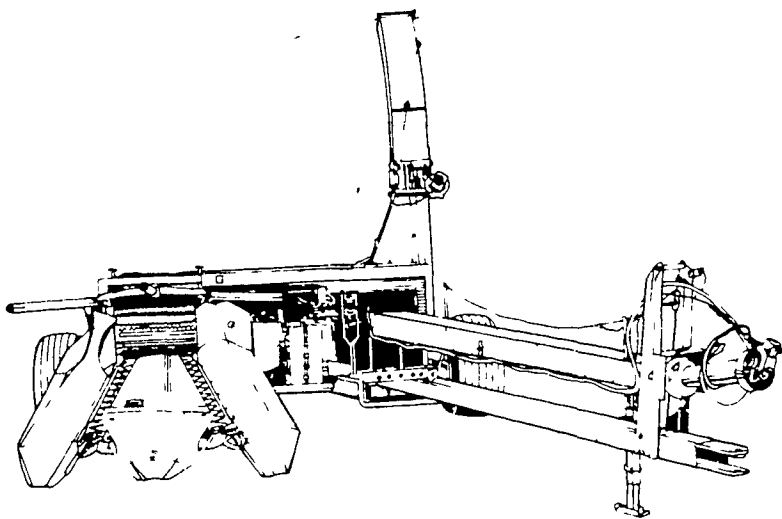

892 Forage Harvester

THE WORLD'S BIGGEST... THE WHOPPER CHOPPER!

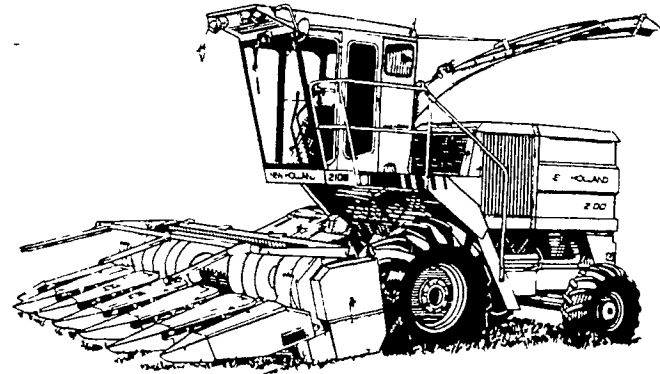

The Model 2100 is designed and constructed for the ultimate in capacity and durability.

WHILE YOU'RE AT THE SHOW, STOP AT THE SPERRY NEW HOLLAND DISPLAY AND ASK HOW YOU CAN SAVE TWO WAYS — NO FINANCE CHARGES UNTIL MARCH 1, 1981 ON HAY AND FORAGE EQUIPMENT PLUS COMBINES. AND LOWER ANNUAL PERCENTAGE RATES WHEN YOU USE THE SPERRY NEW HOLLAND RETAIL INSTALLMENT PLAN.

SPERRY  NEW HOLLAND