

PROGRESS DAYS 1980

By Our "Hands On" Display

May Items To Be Demonstrated

Products of
RYDER SUPPLY CO.

GLASBORD®

ELIMINATES THE EPOXY AND OTHER YEARLY COSTLY MAINTENANCE TO WALLS AND CEILINGS

FOR FARM BUILDINGS
←CLEANABLE DURABLE→

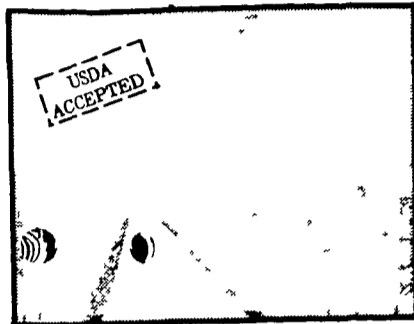

- MOISTURE PROOF
- RUST PROOF
- STAIN RESISTANT
- ODOR FREE
- WILL NOT ROT
- CLEANS SIMPLY & QUICKLY
- USDA ACCEPTED

FORCED PLASTIC

STOUGH AND ABRASION

INSTALLS EASILY
ON WALLS, HOLDINGS, SLAUGHTER

RESISTS DIRT, CORRODE, WASTES ORDINARY

IN STOCK - AVAILABLE NOW

3/32 & 1/8" THICKNESS,
4 x 8 FT. PANELS
3/32 & 1/8" - 4 x 40
AND 4 x 45 FT. ROLLS

ALL CORNER MOLDING AND FASTENERS



VINYL MOLDINGS ARE AVAILABLE TO GIVE A FINISHED APPEARANCE & A WATERTIGHT INSTALLATION.

Automatic ELECTRIC FEED PROCESSOR (Automation Mill)

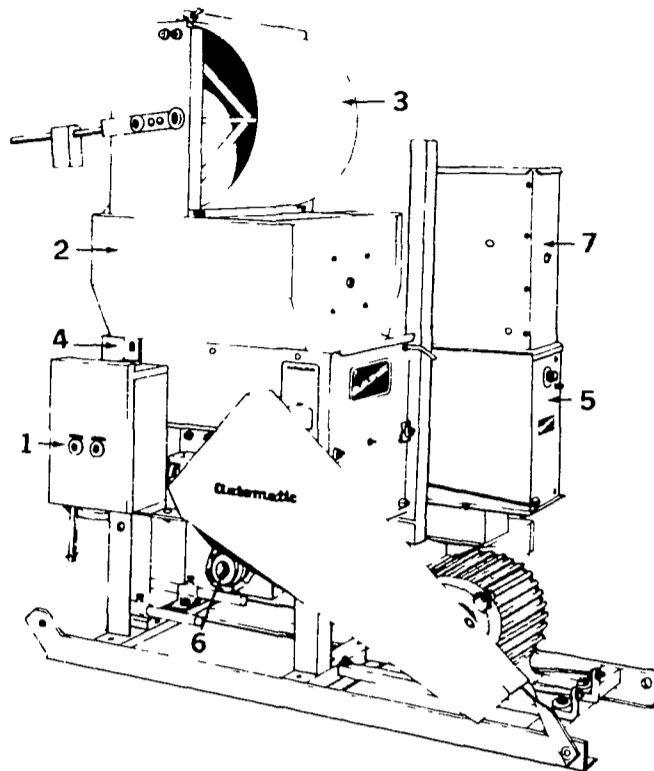

Process and blend 3 or more Ingredients at one time!

(1) Control center (Type III timer system) predetermines and records amount of feed grain (2) Bin Switch regulates input auger, automatically controls grain level in hopper, (not visible), (3) Automatic scale meters preset amount of grain through roller mill, operates automatically and continuously without power, (4) Automatic Roller mill with fast-roll attachment rolls grain, (5) Dial-controlled variable speed augers in electronic meter let you add protein, mineral or medication into mixing auger, (6) Mixing auger mixes and delivers processed feed to take-away auger Supply auger and mill processed preset amount of grain, (7) Accessory hopper with flow switch

Note: The Automatic Dump Scale and feed metering units may be gravity fed from overhead bins or hoppers Flow-control switches are required if input augers are used in place of gravity flow

EAR CORN UNIT

Automatic's ear corn unit handles wet, shucky and even frozen ear corn. The crusher unit shreds the cob followed by rollers that crack the corn, producing a flaky, dust-free feed for greater digestibility. The hydraulically driven intake auger swings to the rear for transport and may be operated at any angle from rear to side.

Dust-free rolled grain is more palatable, easier to digest, eliminates wheezing and many digestive disorders.

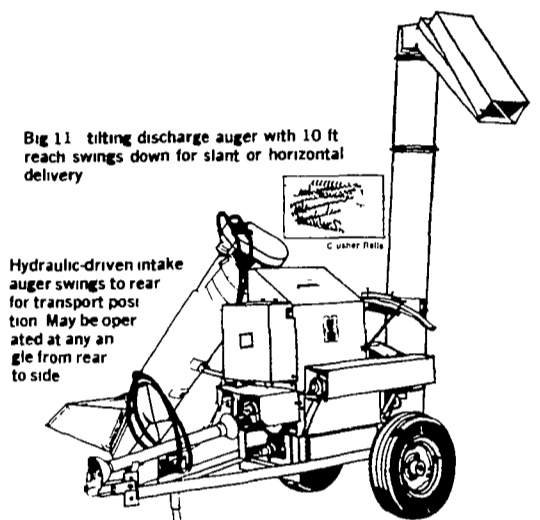
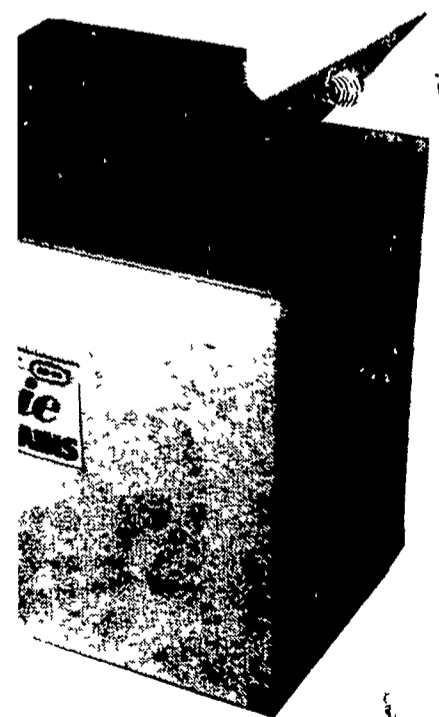

Fig 11 tilting discharge auger with 10 ft reach swings down for slant or horizontal delivery

Hydraulic-driven intake auger swings to rear for transport position. May be operated at any angle from rear to side.

Ritchie Fountains deliver. Even in the dead of winter they are out there working. You're not weatherproof. You bet they are. Heating systems and efficient insulation keep water ice free just set the Watt Watcher™ thermostat for minimal energy use. Big throated, non stick plastic valves keep water gushing in. Each of your cows get all the water they need to promote peak production. Ritchie Fountains are tough, too. Quality built with rugged heavy galvanized steel and CD 50 epoxy finish to stand up to weather and barnlot abuse. Why take chances on anything less than a red and yellow Ritchie fountain? Call your Ritchie dealer for water that won't quit.

THAT WON'T QUIT



RELAX
Ritchie
WATERS EM RIGHT™

Tenderfoot The Original and Still No. 1

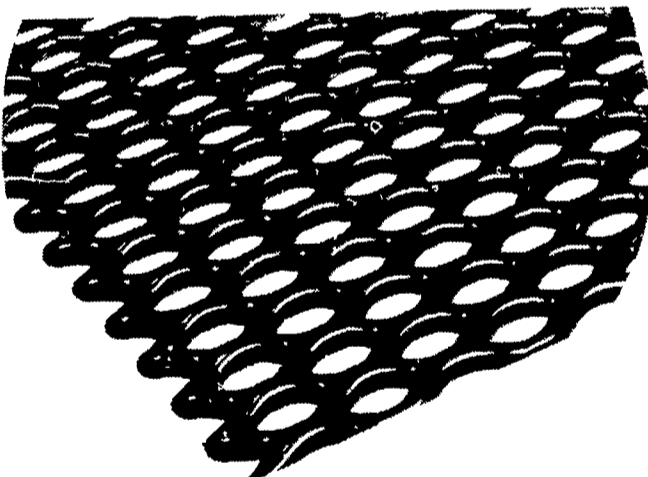

Livestock Flooring Fights Stress 4 Ways

- 1** IN FARROWING CRATES
helps piglets avoid crushing, reduces health problems involving poor sanitation, chilling, cuts and abrasions, promotes udder massage
- 2** IN NURSERY PENS AND DECKS
Tenderfoot stays cleaner, is warmer and virtually eliminates cuts and abrasions caused by bare metal or concrete
- 3** AS FINISHING FLOORS
cleanliness, sure-footed security and comfort of Tenderfoot helps fight stress to keep hogs gaining efficiently
- 4** IN BREEDING PENS
boars and sows are sure-footed on Tenderfoot, perform like on dirt, with no fear of slipping or injury

THE BEST AND LARGEST LINE OF SPECIALISTS AVAILABLE ANYWHERE

- **MANURE HANDLING** •
AGROMATIC Hydraulic Transfer Pump
H D Chain Barn Cleaners
AGROMATIC Cable Barn Cleaners
FEED EASY Vacuum Tanks
FEED EASY 1500 thru 3000 gal Liquid Manure Tanks
FEED EASY Agitator/Filler Pumps
- **POWER FEEDING** •
WEAVERLINE Powered Silage Carts
ROTO-FEEDERS (Lazy-Susan)
AGROMATIC 9" & 12" Auger Feeders
S S Shaker Feeders
- **SELF-FEEDING** •
SERV-O-MATIC Feeder
IDEAL Round Cattle Feeders
IDEAL Hog Feeders
Fiberglass Push Silage Cart
Mineral & Salt Feeders
CIRCLE Bulk Storage Bins 3 to 50 Ton
- **SILAGE & GRAIN HANDLING** •
FEED EASY Double Auger Silo Unloaders
Silage Conveyors
FEED EASY (TMR) Mixer Feeder Wagons
Supplement Meters
Automatic Roller Mills
Dump Scales
JET FLOW 4" & 6" Utility Augers
CIRCLE Grain Storage
- **BARN EQUIPMENT** •
 Water Bowls
 Cow Mats
 Free Stalls
 Comfort Stalls
 Hoof Trimming Stalls
 Ventilation Systems (Exhaust & Tube)
 Kozy-Komfort Calf Stalls
- **MY-D HAND** •
 Head Gates
 Squeeze Chutes
 Portable Corrals
- **LIVESTOCK WATERERS** •
RITCHIE Cattle Waterers
RITCHIE Hog Waterers
IDEAL Stock Tanks
RITCHIE HogFount-S S Construction
- **ELECTRIC POWER PLANTS** •
(550 to 150,000 Watts)
 KATOLIGHT PTO Alternators
 Engine Driven Portable & Automatic
- **HAY HANDLING** •
 GRAVES Bale Elevators
 GRAVES 3 Pt Bases w/Forks
 GRAVES Speed Wagons
 Slant Bar Hay Feeders
- **SPECIALTIES** •
KEMILITE Glasbord
IDEAL Farrowing Crates
IDEAL Tubular Gates
Livestock Scales
Ornamental Windmills
TENDERFOOT Livestock Flooring
Bedding Chopper

RYDER SUPPLY CO. 8/16
P O Box 219 RR 8 (Falling Spring Rd)
Chambersburg Pa 17201 PH 717 263 9111

NAME _____
ADDRESS _____
PHONE _____

Please have a Ryder rep phone me
Send Literature Checked Above

SUPPLY CO.

539 FALLING SPRING ROAD, P.O. BOX 219
CHAMBERSBURG, PENNSYLVANIA 17201
PHONE: 717-263-9111

SEE ON DISPLAY AT
AG PROGRESS DAYS-
AUGUST 19, 20, 21