



# Talk to the man who knows

**Pump...Agitate...Fill!** The versatile Badger Northland Pump/Agitator is available now! The portable Badger Northland BN 103 is built for years of tough, dependable, high capacity performance. It's versatile enough to handle anything you can give it. Designed to pump and agitate pits or lagoons, it can also be used as a manure transfer system for transferring manure from holding pits to lagoons or other storage facilities. Choose the gearbox that matches your tractor's horsepower and PTO RPM.

The BN 103 features an agitator nozzle which sweeps a full 300° for thorough agitation. Reaches all corners of the pit or lagoon.

Add to this the pitched blade of the "Scuper-Charger" which moves material into the impeller for smooth, uniform high capacity pumping. The semi-cupped design of four paddles develops more pressure for mixing settled solids. Breaks up crust.

See your Badger dealer now. Ask him to show you how the BN 103 and other Badger manure handling products can add dollars and cents efficiency to your operation.

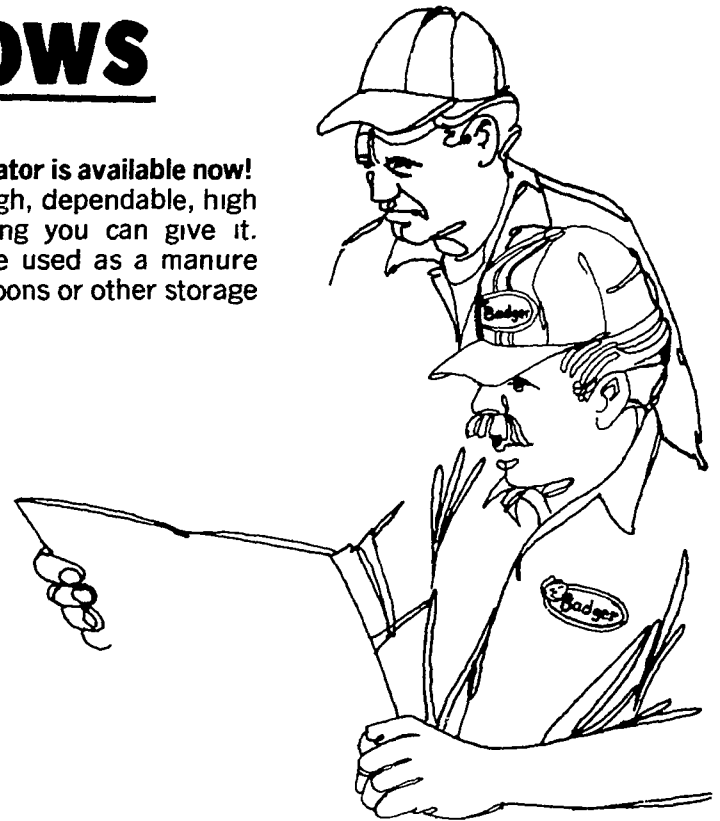
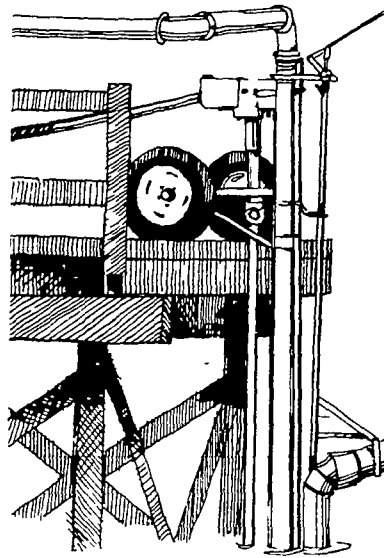

**The Badger Souper-Trail Lagoon Agitator/Pump for long reach . . . fast agitation and fast fill.**

Now you can pump solid or liquid manure from storage basins quickly and efficiently without the need for ramps or docks.

That's right. The Badger Souper-Trail Agitator/Pump is a powerful, rugged and versatile piece of equipment. It transports easily behind your tractor.

The Souper-Trail is easy to position and can be used in any depth lagoon. And its long reach and high capacity pumping allows for fast economic agitation of large manure basins. It will quickly fill even the largest manure tank.

Other features include a special chopper blade rotating ahead of the impeller housing. The heavy-duty hydraulic controlled spout breaks up large clumps and surface crust. Mixes settled solids.

Your dealer has two Souper-Trail models available for use with either 540 or 1000 tractors. See him now and count on him for all your manure handling system needs.

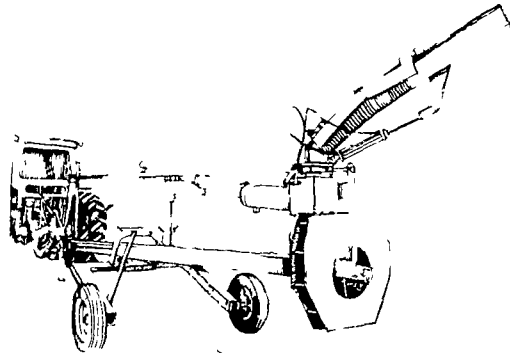

**The best built, fastest and easiest unloading spreaders money can buy!**

You convert to a liquid manure system to save time and labor and increase the overall efficiency of your operation. You don't want to buy short when it comes to unloading and spreading equipment. And that's where the Badger 2300, 1500 and 1000 vacuum tanks come in. These husky vacuum spreader tanks unload fast. Cuts field and tractor time. 2300 and 1500 feature rugged "walking tandems" that make spreading easier, even in rough fields. 1500 and 2300 gallon tanks are also available in models with spreader capabilities.

Here's a tank with time saving capacity. 3000 gallons big, it makes fewer trips with less labor. Supported by two pairs of large flotation tires, the Badger 3000 literally floats over plowed fields or rough roads. Other features include full length skid supports, extra heavy "A" frame tongue, hydraulic controls and a tractor actuated braking system. The Badger 3000 . . . for BIG jobs.

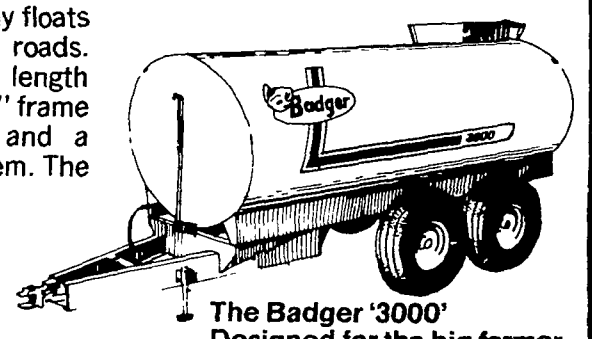
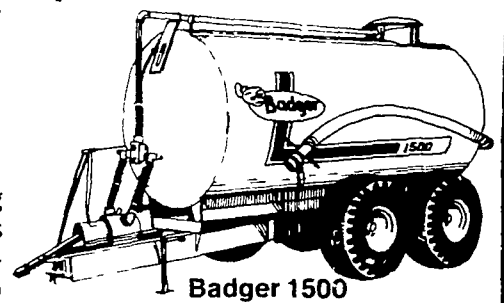
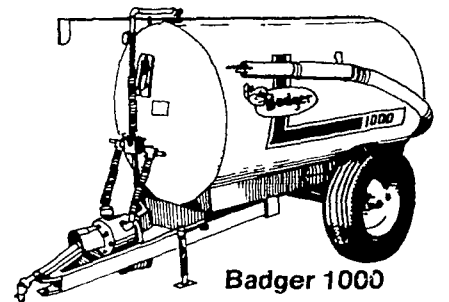

**No agitation job is too tough for the Souper Mix Blender!**

Now you can quickly restore that heavily crusted and weed covered manure basin to a free-flowing slurry for easy pumping.

The Souper Mix Blender is built tough to last with rugged construction throughout. Features large aggressive propeller with strong 3 point hitch.

See your Badger dealer now. Ask him for his ideas on how to achieve efficient profitable manure management in your operation.

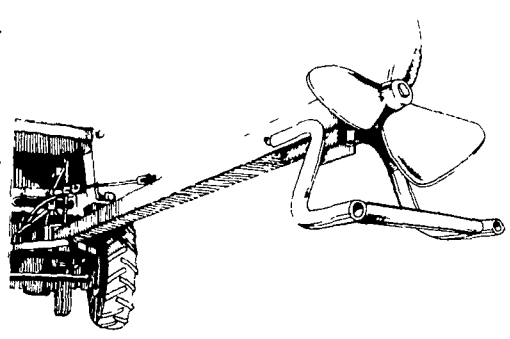

See your Badger dealer between now and July 31st and **CASH IN ON MANURE ASSETS!**

That's right, call your dealer and arrange to have him do a cost projection on what you can save with a Badger manure handling system and get a chance to win a FREE manure agitator, pump or spreader. Nothing to buy and no obligation . . . call him now!



**WAIVER OF FINANCE NOW AVAILABLE**

- ★ Till Sept. 1, 1980 on MANURE SPREADERS
- ★ Til Oct. 1, 1980 on LIQUID MANURE EQUIPMENT

## CONTACT THE BADGER EQUIPMENT & SERVICE PROFESSIONAL IN YOUR AREA

**GRUMELLI'S FARM SERVICE**

Mechanics Grove  
Quarryville, PA 17566  
(717) 786-7318

**McMILLEN BROS.**

RD 1  
Loysville, PA 17047  
(717) 789-3961

**REX RUSSEL EQUIPMENT**

RD1  
Rome, PA  
(717) 247-7858

**SHOW-EASE STALL CO.**

523 Willow Rd  
Lancaster, PA 17601  
(717) 299-2536

**AUMILLERS SALES & SERVICE**

RD 1 - Box 63  
Milroy, PA 17063  
(717) 667-2115

**JOHN BROWN**

RR 1  
Forksville, PA 18616  
(717) 924-3492

**PIKEVILLE EQUIPMENT INC.**

RD 2  
Oley, PA 19547  
(215) 987-6277

**ROY O. CHRISTMAN**

RD 1  
Hamburg, PA 19526  
(215) 562-7218

**RALPH KETTERER**

Deep Run Road  
Perkasie, PA 18944  
(215) 766-8531

**KNUD HERMANSEN**

RD 2  
York Springs, PA 17372  
(717) 766-3639

**LLOYD E. KREIDER**

RD 1  
Cochranville, PA 19330  
(215) 932-4700

**MECKLEY DALMATIA**

Box 147  
Dalmatia, PA 17017  
(717) 758-3021

**CECIL DAIRY SERVICE**

RD 1 Rt 274  
½ Mi South Rising Sun, MD 21911  
(301) 658-6923

**ALLEN ZEIGLER**

RR 1  
Leighton, PA 18235  
(717) 386-4593

**MARLIN W. SCHREFFLER**

Pitman, PA 17964  
(717) 648-1120