

**CENTRAL TRACTOR**  
**FARM & FAMILY CENTER**

**Hurry!**

Sale prices good only through  
**Saturday, Feb. 16, 1980**

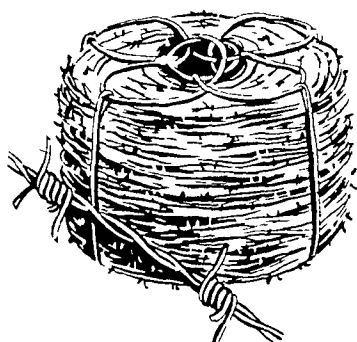

**29<sup>97</sup>**

Reg. 33.97 / SAVE 4.00  
 24672-282

**4 Pt. Barb Wire**  
 12½ gauge, 4 pt wire. 5" spacing. 80 rod spools. Made in USA

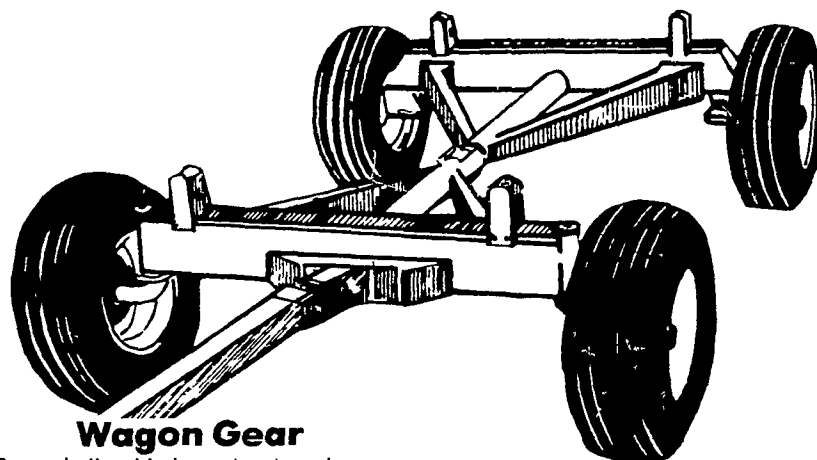

**Wagon Gear**

Rugged all-welded construction, heavy duty spindles, adjustable wheel base, standard tongue, and 5' reach (additional charge for longer reaches) All come less tires

**49<sup>99</sup>**

20320-159 F E T 1 38  
**9.5L x 15" 8 Ply Hi-Flotation Tires**

**50<sup>99</sup>**

20319-159 F E T 1 55  
**11L x 15" 8 Ply Hi-Flotation Tires**

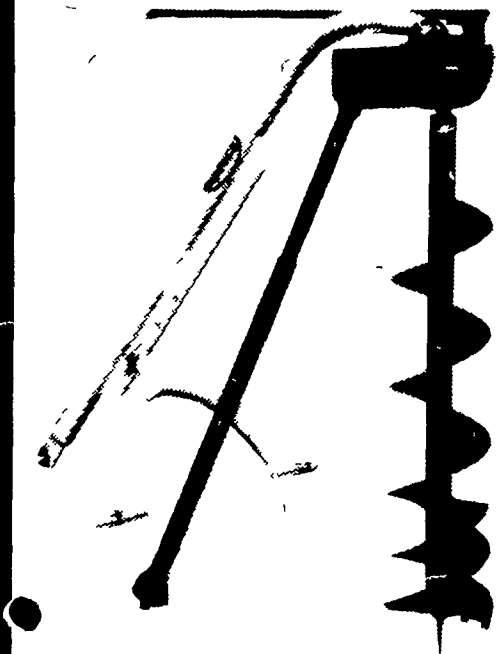

**277<sup>88</sup>**

Reg. 347.88 / SAVE 70.00  
 20226-157

**9" Post Hole Digger**

**298<sup>88</sup>**

Reg. 368.88 / SAVE 70.00  
 20227-157

**12" Post Hole Digger**

Three point hitch hookup, frame made of high strength steel tubing, gearbox has special alloy gears. Made to last.

**5 Ton**  
 8030-046 Reg 369 95 **319<sup>95</sup>**

**6 Ton**  
 8039-046 Reg 429 95 **379<sup>95</sup>**

**8 Ton**  
 8045-046 Reg 479 95 **429<sup>95</sup>**

**10 Ton**  
 8059-046 Reg 569 95 **519<sup>95</sup>**

**54<sup>99</sup>**

Reg. 60.99 / SAVE 6.00  
 3"x8" 6501-017

**59<sup>99</sup>** Reg 64.99 / SAVE 5.00  
 3½ x 8 6585-017

**Tie Rod Cylinder**

Double acting. Up to 2500 psi., 20¼" retracted length, 8" stroke, 1-3/8" rod diameter

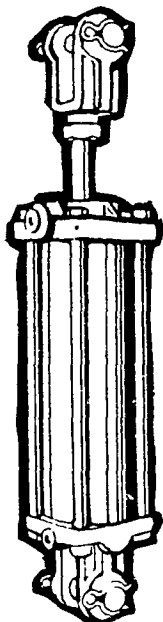

**589<sup>99</sup>**

Reg 669.99 / SAVE 80.00  
 150 gallon 16521-100

**629<sup>99</sup>** Reg 719.99 / SAVE 90.00  
 200 gallon 16714 100

**3 Pt. Sprayers**

Quick, easy to attach, and simple to operate 3-point hitch 8 row sprayer with polyethylene tank Fits tractors with Cat 1 or 2 three point hitches 7/8" pins for category 1, order bushings to bush 7/8" pin to 1-1/8" for category 2 Less pump

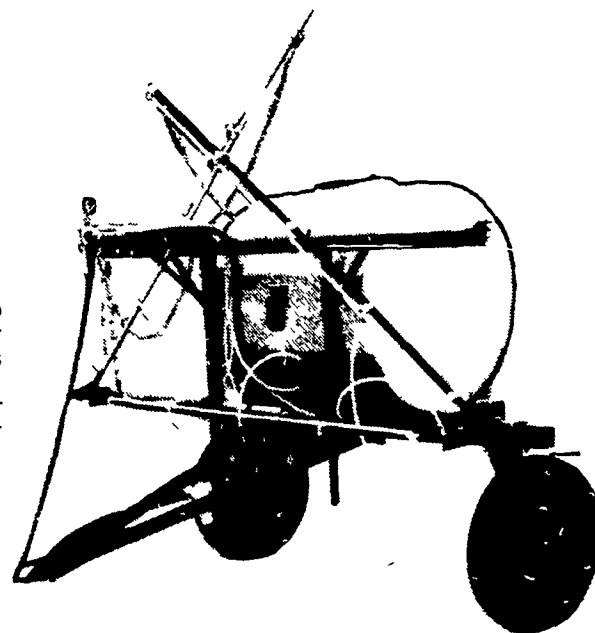

**1199<sup>99</sup>**

Reg 1349.99 / SAVE 150.00  
 16560-100

**500 Gal. Field Sprayer**

This big 10 row, 21 nozzle sprayer will give approximately 35 ft. coverage. Comes with ½" hose booms (standard EVA tubing), nylon fittings on booms and hoses, and high speed Timken bearings and 15" rims (less tires) The heavy duty axle trailer gives you a 40" row width down to any row width desired plus complete visibility 20 GPA tips standard, other tips available Less pump and tires

**769<sup>99</sup>**

Reg 869.99 / SAVE 100.00  
 200 Gallon 16440-100

**879<sup>99</sup>** Reg 999.99 / SAVE 120.00  
 300 Gallon 16511 100

**Field Sprayer**

Polyethelene tank, 8-way selector valve, 20 gallon tips, 2 braid hose, ¾" suction hose and ¾" nylon type strainer 8 row boom, tread easily adjustable from 51" to 88", comes less pump and tires.

**41<sup>88</sup>**

Reg. 47.97 / SAVE 6.09  
 6 Roller Pump 16380-100

**52<sup>88</sup>** Reg 62.97 / SAVE 10.09  
 7 Roller Pump 16470 100

**Roller Pumps**

Backport pump with quick coupler, jumbo nylatron rollers, cast iron body with stainless steel drive shaft Pump capacity is 9.2 gpm at 550 rpm. Pressure range is 0 to 200 psi.

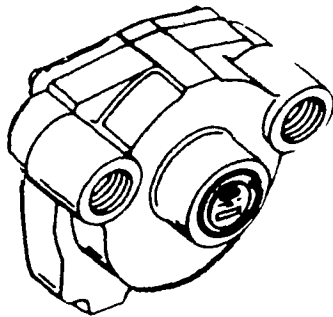

**78<sup>88</sup>**

Reg 86.97 / SAVE 8.09  
 16471-100

**7 Roller Ni-resist Pump**

7 roller twin port pump with quick coupler Ni-resist body, jumbo nylatron rollers, 7/8" stainless steel shaft 15 gpm at 550 rpm Pressure gauge from 0 to 200 psi



**FARM & FAMILY CENTER**

**LANCASTER**

1570 Manheim Pike, Hwy 72 North  
 Ph 717-569-0111  
 Sale Hours  
 8 to 6 00 Monday - Thursday  
 8 to 6 Friday, 8 to 5 Saturday

**SHAMOKIN DAM**

Orchard Hills Shopping Plaza, Rt 11 & 15  
 Ph 717-743-1911  
 Sale Hours  
 Monday Thru Wednesday 9 to 6  
 Thursday and Friday 9 to 9, Sat 9 to 6

**CHAMBERSBURG**

1351 Lincoln Way East  
 Ph 717-264-8282  
 Sale Hours  
 9 to 6 Monday - Thursday  
 9 to 9 Friday, 9 to 5 Saturday

All items are subject to stock on hand  
 We reserve the right to limit quantities  
 Sale ends on the above date