

## Schuylkill County DHIA Monthly Report

**SCHUYLKILL HAVEN** — Ten year old Sugar, of the Miller and Rex, Inc herd, was the cream of the crop during her 305 day lactation record for Schuylkill County's DHIA. This cow led the county with 928 pounds of fat and 23,078 pounds of milk.

Mollie, a six year old in the William R. Daubert herd, turned in a record that ranked second in the county. She milked 21,370 pounds with 873 pounds fat.

Out of the forty-nine cows completing lactation records of over 600 pounds milkfat, one beat the 900 pound level, eight were over 800 pounds, fourteen gave over 700 pounds, and 27 made over 600 pounds fat.

Miller & Rex, Inc. were the high herd in pounds of milkfat per cow per day with 2.07 pounds for their 35.4 cows on test.

The following herds are reported from the IBM report for December 1979. A total of 860 cows were tested. Only herds averaging 1.4 lbs. of milkfat per cow per day or over, and on an official program are reported. The report on individual cows includes only those reported and producing over 600 lbs. of milkfat.

OWNERS	NO COWS	LBS MILK	LBS FAT
Miller & Rex, Inc.	35.4	49.4	2.07
Suntrail Dairy Farm	52.2	48.3	1.85
William R. Daubert	81.5	39.9	1.75
Wilbert Moyer	37.8	44.9	1.72
Carl & Dale Heisler	62.8	47.4	1.70
Emmett W. Rhein	75.4	34.0	1.62

Martin L. Daubert	32.0	35.3	1.57	Doris	6.4	21,904	753
John P. Leatherman	51.6	41.6	1.56	Ginger	5.9	21,412	654
Bruce Leatherman	67.9	45.1	1.52	Elam Z. Stoltzfus			
Paul Heisler	50.4	39.2	1.51	49	5.0	21,932	834
Lester D. Moyer	31.6	37.9	1.49	Freda	3.1	14,594	636
Elam Z. Stoltzfus	37.1	39.4	1.48	John P. Leatherman			
Henry J. Reiner	18.3	35.6	1.43	Melle	7.7	25,930	826
				Wilbert Moyer			
<b>OWNER NAME OR NO.</b>	<b>AGE</b>	<b>LBS. MILK</b>	<b>LBS. FAT</b>	Jubilee	5.5	20,731	804
Miller & Rex, Inc.				Kelly	6.4	19,619	753
Sugar	10.5	23,078	928	Greta	4.4	18,882	697
Belle	4-10	19,813	682	Millic	6.3	16,931	608
William R. Daubert				Bruce Leatherman			
Mollie	6.4	21,370	873	Black	5.3	20,314	800
Polly	7.3	22,360	829	14	8.3	23,008	768
Becky	8.10	19,177	777	Stacy	1-11	17,523	685
Leona	7.0	17,051	763	Suntrail Dairy Farm			
Happy	4.1	16,706	734	Peg	4.9	23,214	767
Jolene	4.5	19,516	712	Arlene	6.4	18,438	708
Queette	4.4	18,939	711	Agnes	6.1	18,038	691
Lucy	5.0	16,257	700	Elsie	3.0	15,172	683
Roxie	4.9	19,085	670	Molly	2.0	18,684	643
Carl & Dale Heisler				San	2.0	16,304	612
10	3-11	17,942	868	Marlin L. Leshner			
21	3.3	23,078	789	Julie	5.2	17,572	730
72	6.4	15,630	692	Emmett W. Rhein			
65	7.2	13,673	676	Nedra	7.7	16,363	702
26	3.1	19,204	606	Norma	5-11	13,521	630
Henry J. Reiner				Martin L. Daubert			
Patsy	8-7	21,282	855	Sleet	5-0	14,863	679

(Turn to Page D15)

# Volumatic<sup>®</sup> III silage distributor-unloader by JAMESWAY<sup>®</sup>

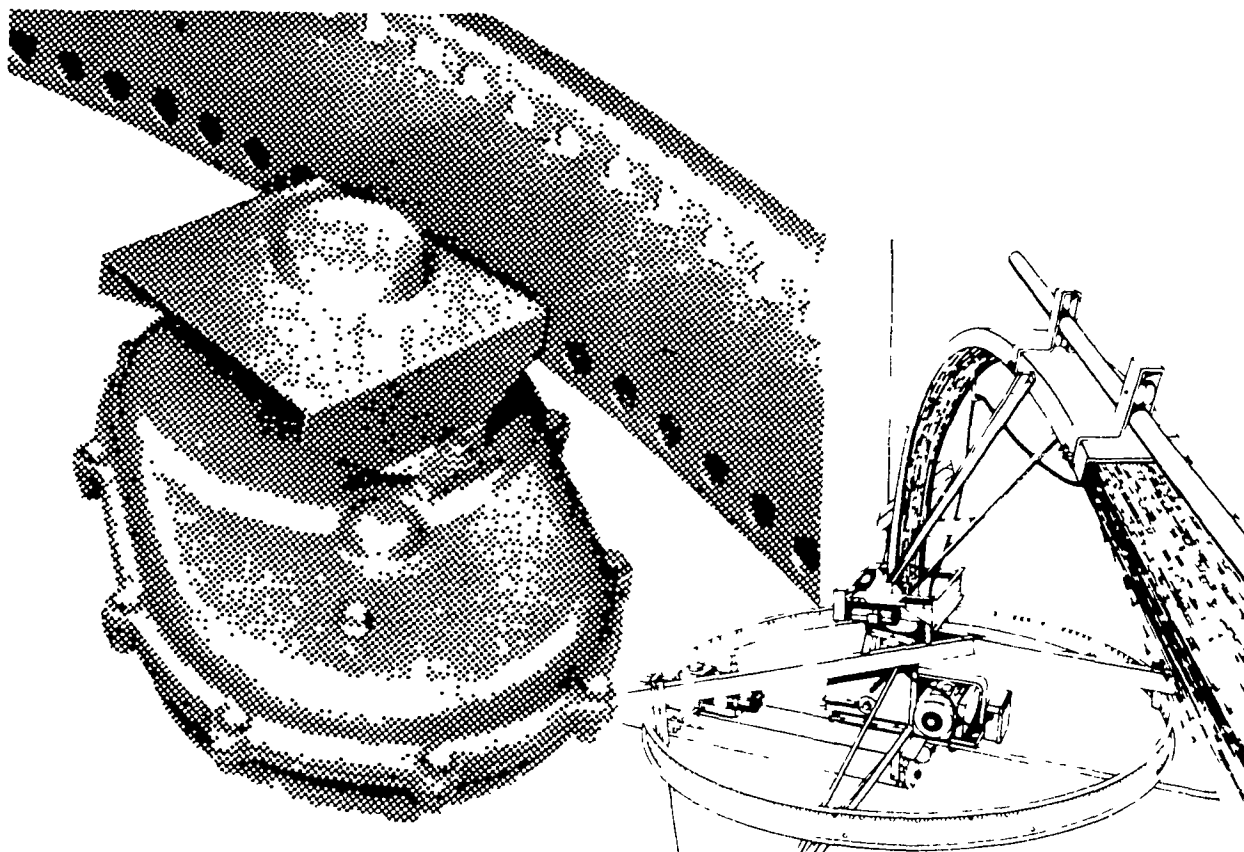

## Get capacity

Another reason why all ring-drive silo unloaders are not alike: Independent power-ring drive, with separate 1/2 hp motor, powers the Volumatic III silage distributor-unloader around the silo. Frees the auger/impeller motor to put its full power into big-volume unloading. Provides positive rack and pinion traction. Features slip-clutch protection.

See us for systems and service that help make the good life better.

### AGRI-EQUIP.

RD4, Farmersville, Ephrata, PA 717-354-4271

### I. G.'s AG. SALES

Rt 113, Box 200 Silverdale, PA 215-257-5135

### ERB & HENRY EQUIP., INC.

22-26 Henry Avenue New Berlinville, PA 215-367-2169

### DEPENDABLE MOTORS

Honey Brook, PA 215-273-3131 215-273-3737

### HENRY S. LAPP

RD1, Cains, Gap, PA 17527 717-442-8134

### M. S. YEARSLEY & SON

114 E. Market St West Chester, PA 19380 215-696-2990

### HARRY L. TROOP

Rt 1 Cochranville, PA 19330 215-593-6731

### TAM SYSTEMS CORP.

RD 1, Mountain Rd. Dillsburg, PA 17019 717-432-9738

### ROVENDALE SUPPLY

RD 2, Watsonstown, PA 17777 717-538-5521

### SOLLENBERGER SILOS

RFD 2, Chambersburg, PA 717-264-9588

### J. A. SWOPE

Box 121, RD1 Myerstown, PA 717-933-4758

### DETWILER SILO REPAIR

Rt 2, Newville, PA 717-776-7533

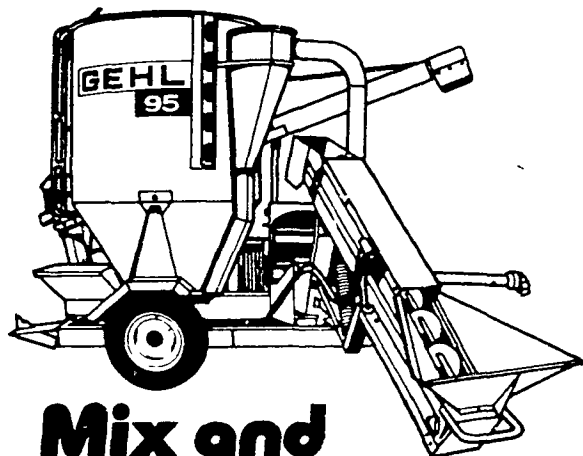

## Mix and feed with ease

Handle grinding and mixing chores in a hurry with a Gehl Mix-All<sup>®</sup> Hydraulic and mechanical drives available for easy loading. And big 21" mill grinds feed efficiently. Unloading auger with optional extension lets you unload just about anywhere. See us today and learn more about the Mix-All.



### PEOPLE'S SALES & SERVICE

Oakland Mills, PA 717-463-2735

### N.G. HERSHEY & SON

Manheim, PA 717-665-2271

### A. L. HERR & BRO.

Quarryville, PA 717-786-3521

### S. JOHNSON HURFF

Pole Tavern Monroeville, NJ 609-358-2565 or 609-769-2565

### STOFFER BROS. INC.

Chambersburg, PA 717-263-8424

### ARNETT'S GARAGE

Rt 9 Box 125 Hagerstown, MD 301-733-0515

### UMBERGER'S MILL

Rt 4 Lebanon, PA (Fontana) 717-867-5161

### ZOOK'S FARM STORE

Honey Brook, PA

### BINKLEY & HURST BROS.

133 Rothsville Station Road Litz, PA 717-626-4705

### AGWAY, INC.

Chapman Equip. Center Chapman, PA 215-398-2553

### KING'S TOWN TRACTOR CO., INC.

Rt 213 South Chestertown, MD 301-778-1640

### CHAS. J. MCCOMSEY & SONS

Hickory Hill, PA 215-932-2615

### WERTZ GARAGE

Lineboro, MD 301-374-2672

### LEBANON VALLEY IMPLEMENT CO., INC.

Richland, PA 717-866-7518

### CLAIR J. MYERS

Lake Road R1 Thomasville, PA 717-259-0453

### COLUMBIA CROSS ROADS EQUIP.

RD 2 Box 62 Columbia Cross Roads, PA 717-297-3873 717-297-2991

### PETERMAN FARM EQUIPMENT, INC.

225 York Rd Carlisle, PA 717-249-5338