

Grassland FFA

(Continued from Page 114)

Longenecker, daughter of Dr. Joseph and Mrs. Longenecker, Denver R1; 9. Dennis Weaver, son of Mr. and Mrs. John M. Weaver, New Holland R1; and 10. Mervin Zimmerman, son of Mr. and Mrs. Mervin B. Zimmerman, East Earl R2.

The top placing team consisted of ninth-graders from the New Holland Production class. They were Rodger Weaver, Jeff Snader, David Mull, Sheila Eager, and Lilly Fisher, daughter of Mr. and Mrs. Daniel E. Fisher, Blue Ball.

The second place team came from the 10th grade New Holland Environmental class. Along with Wanda and Doug, team members were Darlene Horning, Ruth Cox and Cindy Boyd.

The second team from the New Holland Production class came in third. Team members were: Kevin Martin, Mervin Zimmerman, Gerald Weaver, Dean Nolt, and Dennis Weaver.

The fourth team was the

second New Holland Environmental team. Members were: Janis Longenecker, Reggie Bennett, Scott Buzzard, Matt Schnader, and Daryl Weinhold.

Placing fifth was the Ephrata team consisting of Charles Bewley, Harold Kauffman, Ray Good, Harry Becker, and Ray Good.

Solanco and Manheim Central High School FFA members also took part in the competition, but did not place in the top five.

The FFA members had five sites, four to six feet deep to judge. They determined the slope, stoniness, texture of surface soil, depth of topsoil, depth of soil and internal drainage. They then determined the capability class of the soil for agriculture, identifying natural limiting factors. The land judges made land use and conservation recommendations for each site. They also evaluated the site for a house, septic tank and disposal field, and lagoon building.

The top land judges from each school will compete in the state contest this Summer at the Pennsylvania State University. The national competition will be held next Spring in Oklahoma City.

Officiating at the contest was Southeastern Regional Soil Conservation Specialist Albert Backer of Lebanon.

Team coaches included Lou Ayres, Ephrata High School; Philip Oglie, Grassland Environmental chapter, and Robert Woods with the Grassland Production teams.

A special thanks was given to Jay Roy Wise who farms the Zerbe Sister's farm. Wise was instrumental in setting up the judging sites and facilities provided for the FFA members.



The top placing team at the Lancaster County FFA Land Judging Contest included (left to right)

David Mull, Sheila Eager, Rodger Weaver, Lillie Fisher, and Jeff Snader.



WETMORE DIVISION

6, 8, 10, 11 & 12 TONS

WAGON GEARS

Designed with ample safety factor to meet load capacity. Built-in trailability for tractor speed roadability.

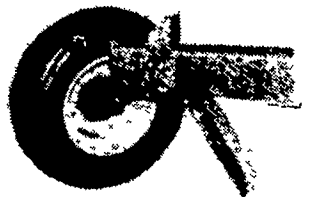

5, 6, and 8-bolt hubs and reinforced axles for greater structural strength. 72" tread to provide more stability. Bolter stakes adjustable from 38" to 42" to fit any hauling job.



Short turn radius and front steer for easy maneuverability. Tapered roller bearings to reduce friction and prolong life of parts.

A FULL LINE OF RUNNING GEARS, RUGGEDLY BUILT AND DESIGNED FOR FORAGE BOX, GRAVITY BOX, FERTILIZER TANK, AND ANY OTHER HAULING WORK IN YOUR FARM OR INDUSTRY.

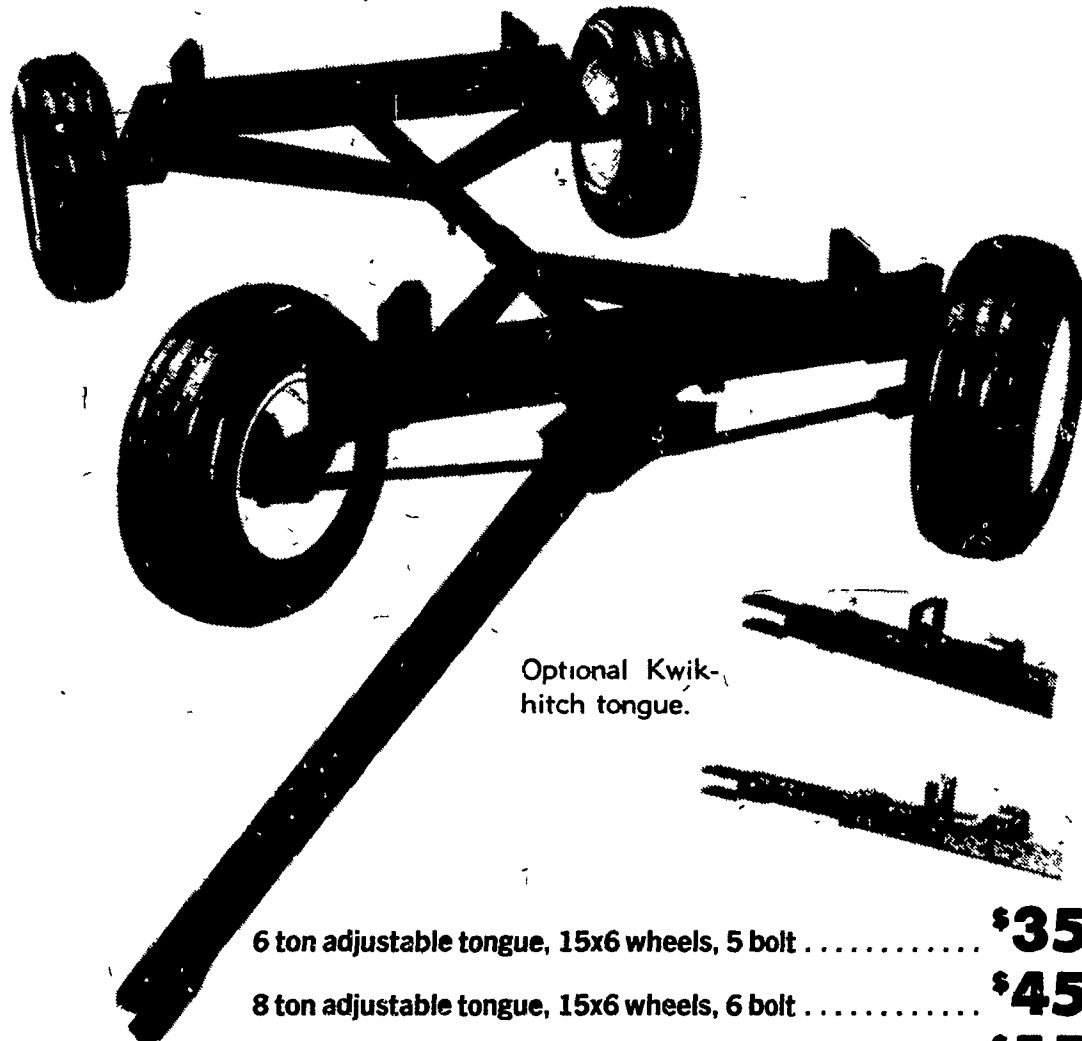

Optional Kwik-hitch tongue.

- 6 ton adjustable tongue, 15x6 wheels, 5 bolt **\$350**
- 8 ton adjustable tongue, 15x6 wheels, 6 bolt **\$450**
- 10 ton quick hitch tongue, 15x8 wheels, 6 bolt **\$550**
- 11 ton tandem quick hitch tongue, 15x8 wheels, 6 bolt **\$750**
- 12 ton quick hitch tongue, 15x10 wheels, 8 bolt **\$750**
- Optional Kwik-Hitch Tongue **\$45**

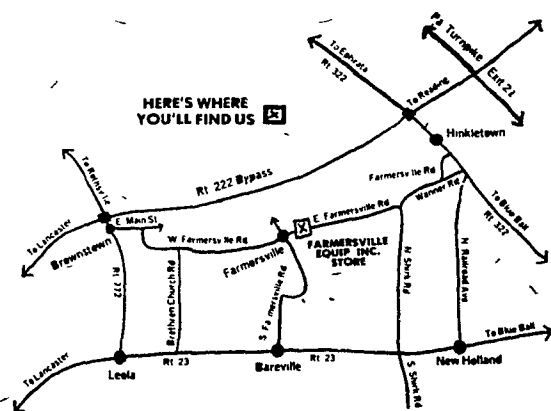

FARMERSVILLE EQUIPMENT

INC.

RD 4, Ephrata, PA

717-354-4271

NEW HOURS

Mon., Tues., Wed., Fri. — 7:30-5:30
Thurs. — 7:30-9:00
Sat. — 7:30-3:00



BARN PAINTING
Call Us Now
For Free
Estimates
PHARES S. HURST
RD 1, Box 420
Narvon, Pa. 17555
215-445-6186

We Specialize in.

- repastering Silos. We use Granite interior finish on all brands of Silos.

- We also tear down and rebuild silos, install silo extensions, new roofs, Lancaster Level-Flo pipe and distributors.

- New Silos, Berg and Farmway Equipment

GUTSHALL'S SILO REPAIR

RD 1,
Womelsdorf, Pa. 19561
Phone 717-933-4616