



CENTRAL TRACTOR



SALE PRICES GOOD SAT. JAN. 20th TO SAT. JAN. 27th, 1979. SALE PRICES SUBJECT TO STOCK ON HAND.

8⁹⁷

Reg. 9.97 / SAVE 1.00
19015-141

50 Lbs. Terramycin Crumbles

Increased disease protection fights in two ways, in the blood and in the gut

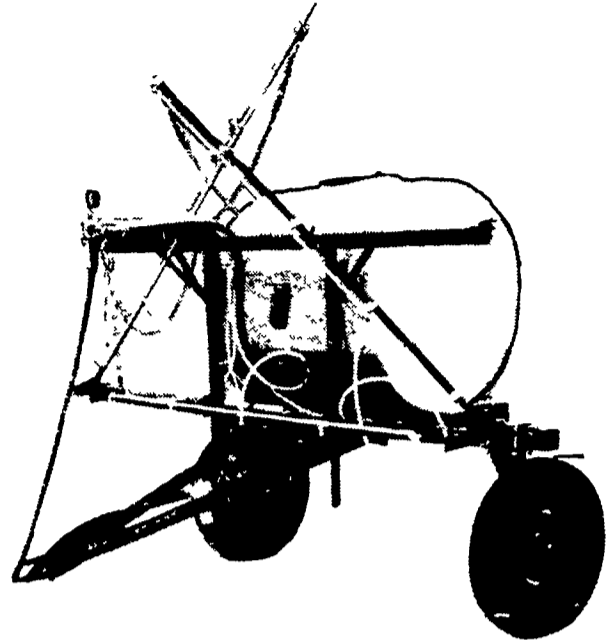
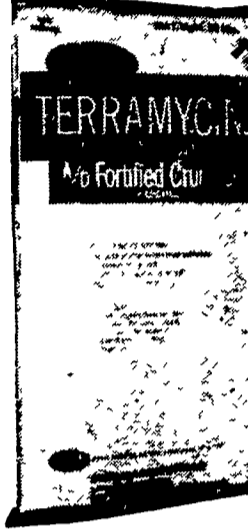

10% OFF ON ALL FIELD SPRAYERS IN STOCK

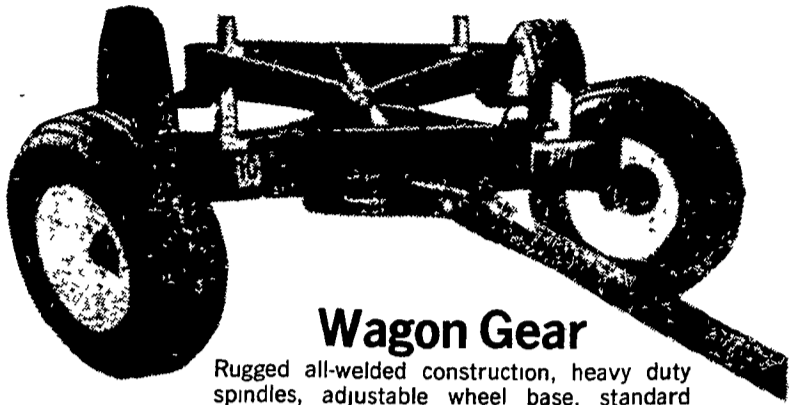

Wagon Gear

Rugged all-welded construction, heavy duty spindles, adjustable wheel base, standard tongue. All units come less tires

- 5 Ton**
8030-046 Reg 314 95 **SALE 299⁹⁵**
- 6 Ton**
8039-046 Reg 359 95 **SALE 339⁹⁵**
- 8 Ton**
8045-046 Reg 399 95 **SALE 379⁹⁵**
- 10 Ton**
8059-046 Reg 484 95 **SALE 459⁹⁵**

49⁹⁹

Reg. 54.99 / SAVE 5.00
6501-017

3" x 8" Tie Rod Cylinder

Double acting. Up to 2500 psi. 3" bore, 8" stroke, 20 1/4" retracted length. Rod diameter 1 3/8"

54⁹⁹

Reg. 59.99 / SAVE 5.00
6585-017

3 1/2" x 8" Tie Rod Cylinder

3 1/2" bore 8" stroke, 20 1/4" retracted length Up to 2500 psi Rod diameter 1 3/8"

4⁶⁶

Reg. 5.88 / SAVE 1.22
27802-285

Golden Choice Dog Food

25 lb. bag. Golden Choice is a complete food supplying all the nutrients necessary to keep your dog in healthy, alert condition

11⁹⁹

Reg. 15.49 / SAVE 3.50
9595-055

Cordomatic Handy-lite Reel

Pull out 18 gauge, 2 wire cord to desired length, up to 20 ft., and it locks, retracts automatically. Bulb protector is plastic

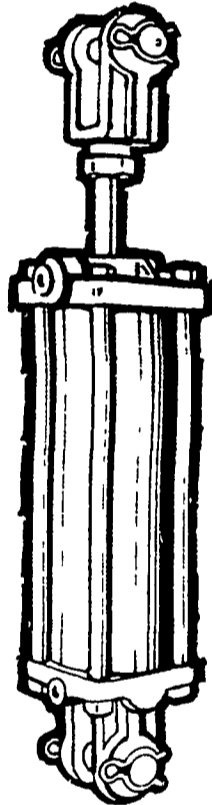
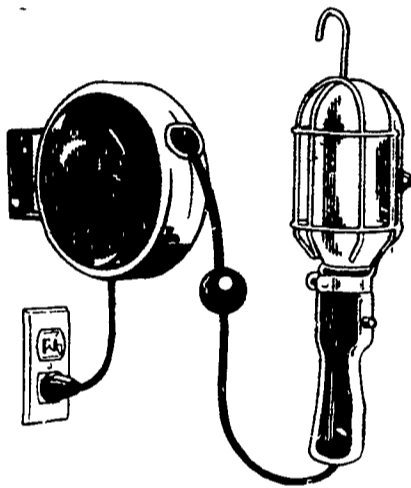

SAVE 2.00
Floating Stock Tank De-Icer

Completely sealed terminal immersion element heats water directly. Alloy construction. Portable, just plug in the 8' power cord. Automatic thermostat control.

1,000 watts **18⁸⁸**
18951 144 Reg 20 88

1,500 watts **21⁸⁸**
18952 144 Reg 23 88

13⁹⁹

Reg. 16.99 / SAVE 3 00
19975-149

8 Lb. Wood Chopper's Maul

Forged high carbon steel head on 36" axe eye hardwood handle. An indispensable tool for the serious wood chopper



99⁹⁹

Reg. 114.99 / SAVE 15.00
20250-157

6 Ft. Economy Tractor Blade

Easily adjusts to 3 angles and tilts with side link adjustment. Withstands 1500 lb pull, designed for tractors up to 30 horsepower

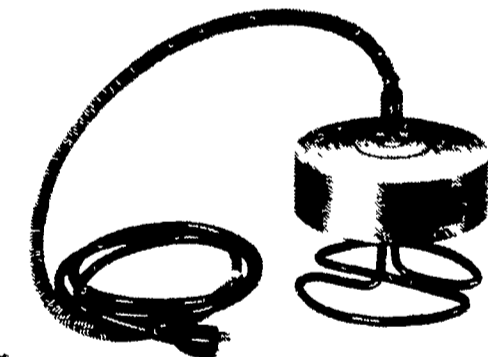

259⁹⁹

Reg. 284 99 / SAVE 25 00
25402-293

High Pressure Washer

Handy cart mobility 500-600 psi, computerized mixing for easy cleaning and spraying. Built-in tank eliminates the need for bottles, etc. Special duty 3/4 Hp motor 5-way valve selects cleaning phase desired. 100% chemical, metered chemical, rinse tank filling, and off 2 gpm pump. 6 ft grounded power cord 3 1/2" high, 1 1/2" wide, 18 3/8" deep. Requires 15 amps power at 115 volts

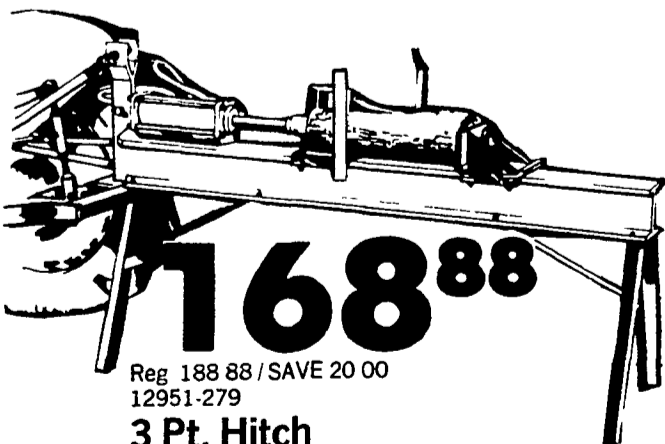

Reg. 188 88 / SAVE 20 00
12951-279

3 Pt. Hitch Wood Splitter

Fits category 1 or 2, allows you to split a cord of wood in less than an hour. Exclusive quick adjust backstop, heavy duty construction, can be used free standing with ground stand or mounted on tractor. Uses 8" to 18" stroke hydraulic cylinder. Does not include cylinder, valve, hoses, or stand

Stand for above 12953-279 **28.99**

FARM & FAMILY CENTER

LANCASTER

1570 Manheim Pike, Hwy. 72 North
Ph: 717-569-0111

Sale Hours:

8 to 6:00 Monday - Thursday
8 to 6 Friday; 8 to 5 Saturday

CHAMBERSBURG

1351 Lincoln Way East
Ph: 717-264-8282

Sale Hours:

9 to 6 Monday - Thurs.
9-9 Friday
9-5 Saturday