

FARM EQUIPMENT

FARM EQUIPMENT

FARM EQUIPMENT

For Sale
Feed Carts & Silage Carts
10" air tire wheels,
made out of 3/4" preserved plywood
C.B. HOOBER & SON
Intercourse, PA
717-768-8231

FARM EQUIPMENT

FARM EQUIPMENT

SPECIAL OF THE WEEK
7 LEASED WAGONS
GOOD YEAR END SALE PRICE

EQUIPMENT FOR SALE OR LEASE

BADGER
3,000 gal. liquid manure tank
1,500 gal. vacuum tank
205 Bushel Manure Spreader
Forage Wagons
Forage Blowers
Persuader Pumpagator for Lagoons
Handy High Pressure Washers
Oswalt Mix Wagons
Also:
Registered Holstein Bulls
SHOW-EASE STALL CO.
573 Willow Rd. Lancaster, Pa.
Ph: 717-299-2536

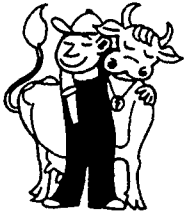

USED TANKS

Good Condition, For Farm & Industrial Use
#2 - 5,198 gal. glass lined, \$1650.
#3 - 5,198 gal. glass lined, \$1650.
#4 - 3,938 gal. glass lined, \$1250.
#5 - 4,725 gal. glass lined, \$1500.
#6 - 5,638 gal. epoxy lined, \$1150.
#7 - 5,638 gal. epoxy lined, \$1150.
All Prices F.O.B. Plus Delivery
E Z MFG. CO.
RD 1, New Holland, Pa. 17557
Phone: 717-354-4348

TRACTOR & MOTOR REPAIRS

Over 20 years experience with Ford tractors and equipment.

Shop & Road Service
Pickup and Delivery
WALT STIVELY, JR.
Springville Road
Quarryville, RD3
Phone 717-786-2252

WANTED

Grain cleaner, 3 screen, capacity 150-300 bushels per hour.
Phone Collect - 302-378-9343
or Write
William A. Cross
Box 23, R.D. 2, Middletown, DE 19709

USED EQUIPMENT

1 4 wheel drive 4-150 White tractor with duals, like new 200 hrs.
1 Case 800 tractor
1 IHC 656 tractor
1 AC 180 diesel
1 H JD with all attachments
1 Farmall 560 tractor w/WF & 18.4x38 tires, Ex. Cond.
1 JD Forage box with roof
1 IHC 6 bottom auto reset plow
1 NH L-35 loader w/backhoe
2 Used elevators
4 Used pickers
COMPLETE LINE OF AC TRACTORS IN STOCK
UNIONTOWN FARM EQUIPMENT
412-437-9851

IF YOU ARE BUYING A 100 H.P. TRACTOR OR OVER... SEE THE 86 SERIES BEFORE THE PRICE INCREASE!

Model 357: Big and tough!

Sperry New Holland grinder-mixers have built-in durability and convenience for more efficiency!

Power bale feeder available to reduce time and manual labor required to feed bales into the grinder-mixer

• Table swings vertical for transport! • Engage and disengage feed table conveyor from either side of housing! • 21-inch mill! — • 120-bushel capacity! • Special hopper (standard) for adding grain into the ration!

The 357 grinder mixer can also be equipped with:
• Loading auger
• Optional hydraulic drive
• Optional electronic scale for accurate control of rations

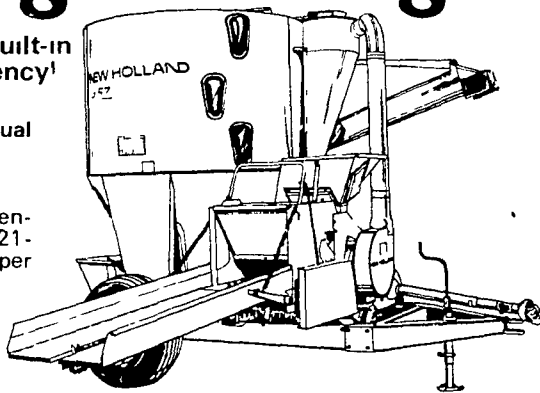

FORRESTER BROS. FARMS

1337 Lincoln Highway East
Chambersburg, PA 17201
Phone: 717-263-0705
We Service What We Sell.

JD 4320	3 Ford 3000
7 JD 4020	Ford Roadless 95 4 wd.
JD 3120	Int. 856
2 JD 2120	Int. 674
5 JD 2020	Int. 574
JD 1020	Int. 454, cab
JD 60 3 pt., w.f.	Int. Farmall H
Ford 8600	MF 175 multipower
3 Ford 8000	Ferguson 35
2 Ford 6700	David Brown 1200
4 Ford 5000	w/loader
3 Ford 4000	
Ford 4000 row crop 63 w.f.	

Field Ready Tractors.

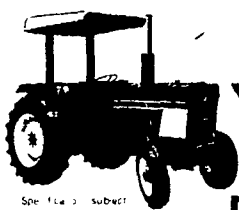

You get more in a new 84

WAIVER OF FINANCE ON NEW & USED

- Harvesters
- Crop Carriers
- Blowers
- Hay Equipment



IH 1586 160 PTO H.P.
TRACTOR RENTAL AVAILABLE

IN STOCK: A COMPLETE LINE OF FALL TILLAGE EQUIPMENT. ★ READY TO GO!

IH Wing Disk Model 475 17'5" Wide.

IH Stalk Shredder Model 50 12'6" Wide.

— Just Traded —
IH 1066 D, 1100 hrs.
IH 756 D, Reconditioned
IH 460 New TA

COMPLETE LINE OF USED EQUIPMENT

NH Model 273 Baler w/Model #226 shredder attach.
IH 315 Packer-Mulcher
IH 1150 Grinder-Mixer
JD Grain Drill
NH 273 Baler
NH 277 Baler
NH 269 Baler
NH 270 Baler

NH Super 717 1-Row Pickup
IH 225 S.P. Haybine
NH 479 Haybine
IH 460 Tractor
IH 211 Plow
IH 311 Plow
IH 50 Harvester
Several Used Spreaders
Several Used Disk Harrows

- SPECIAL -
234 Running Gears
w/31x13.50-15 Tires

Oliver 4 Bot. Semi-Mtd Plow
IH 990 Mower-Conditioner
JD 494 6-Row Planter
NH S.P. 1880 Diesel, 3 Heads, (Good Cond.)

WE'VE ADDED A NEW PHONE NUMBER! 717-653-8867
Now You Can Call Us Toll-Free From Lancaster, Manheim and Surrounding Areas.

MESSICK FARM EQUIPMENT, INC.

RHEEMS EXIT - RT. 283 ELIZABETHTOWN, PA.
PHONE: 717-367-1319 — 653-8867
M. DALE HERR - HOME 859-2490 WARREN SPICKLER - HOME 653-4560



FALL SAVINGS

CALL STEVE OR JACK, WE WILL NOT BE UNDER SOLD ON ANY DEAL!

- ★ Interest Free on New AC Tractors til 3/1/79
- ★ Interest Free on Used Tractors til 3/1/79
- ★ Interest Free on New & Used Combines till 6/1/79

NEW EQUIPMENT
(1) Gleaner M2KS hydro (1)(2) Gleaner F2KS

USED EQUIPMENT
Farmall 400 Tractor (1)(2) AC WD Gas
Ford 2000 Tractor IHC 10' Disc Harrow
Allis Chalmers G NI 702 CombinsOLD
AC D17 Diesel, New Paint, New Tires, MF 510D Combine
Clean MF 410 Combine
AC WD 45 Diesel Gleaner 500 combine, 1968
Ford 8N SOLD Case 960 Combine
Ford 9N SOLD JD 55 C50 combine
Ford 800

TOWNE TRACTOR
Highway 33, Freehold, NJ
201-431-3838