

CENTRAL TRACTOR



CENTRAL TRACTOR



SALE PRICES GOOD AUG. 26 THRU SEPT. 2

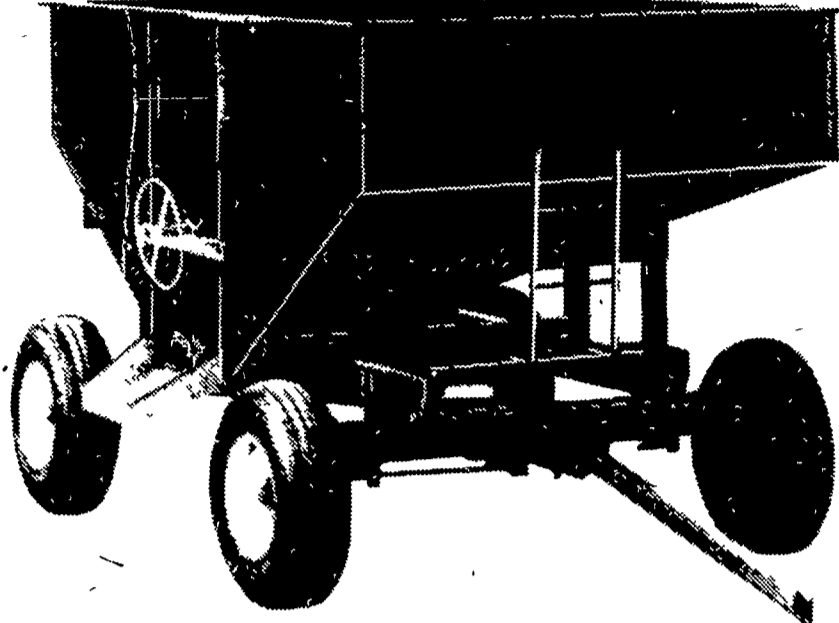

\$339⁹⁵

Frnt. Included

165 Bu. Gravity Box
#28900-250 Reg. \$364.95 + \$30.00 Frnt.

\$449⁹⁵

Frnt. Included

225 Bu. Gravity Box
#28901-250 Reg. \$484.95 + \$30.00 Frnt.
WAGON & TIRES NOT INCLUDED

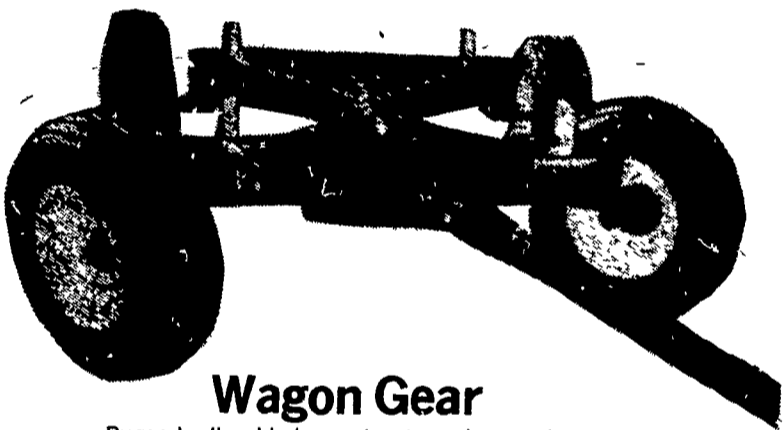

Wagon Gear

Rugged all-welded construction, heavy duty spindles, adjustable wheel base, standard tongue. All units come less tires

5 Ton
8030-046 Reg \$279 95 **SALE 259⁹⁵**

6 Ton
8039-046 Reg \$319 95 **SALE 299⁹⁵**

8 Ton
8045-046 Reg \$364 95 **SALE 344⁹⁵**

10 Ton
8059-046 Reg \$449 95 **SALE 414⁹⁵**

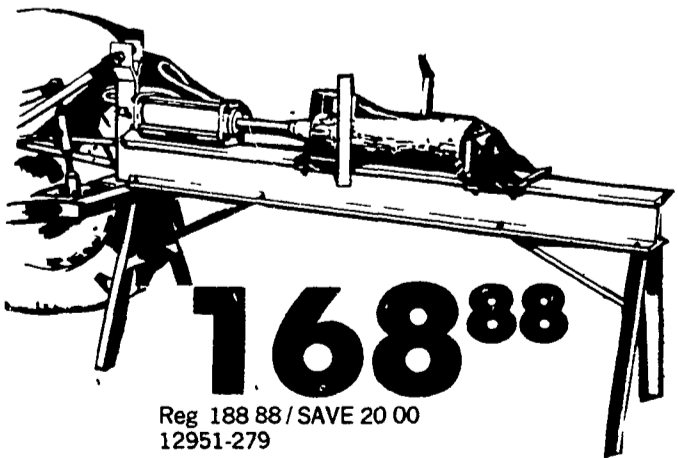

168⁸⁸

Reg 188 88 / SAVE 20 00
12951-279

3 Pt. Hitch Wood Splitter

Fits category 1 or 2, allows you to split a cord of wood in less than an hour. Exclusive quick adjust backstop, heavy duty construction, can be used free standing with ground stand or mounted on tractor. Uses 8" to 18" stroke hydraulic cylinder. Does not include cylinder, valve, hoses, or stand.

Stand for above 12953-279 **28.99**

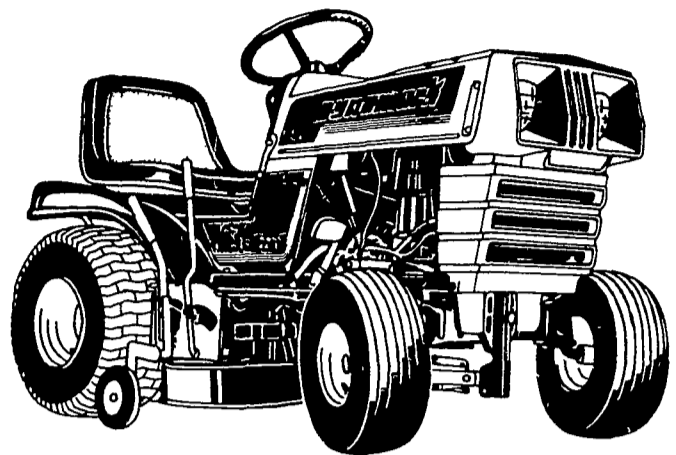

699⁹⁹

Reg 799 99 / SAVE 100 00
22501-258

10 Hp. 36" Rear Discharge

The newest innovation in riding lawn mowers. Grass clippings are ejected to the rear instead of side, to prevent clogging. Includes electric starter, alternator, sealed beam headlights, twin blades for 36" cut, gas and ammeter gauges, and rack and pinion steering.

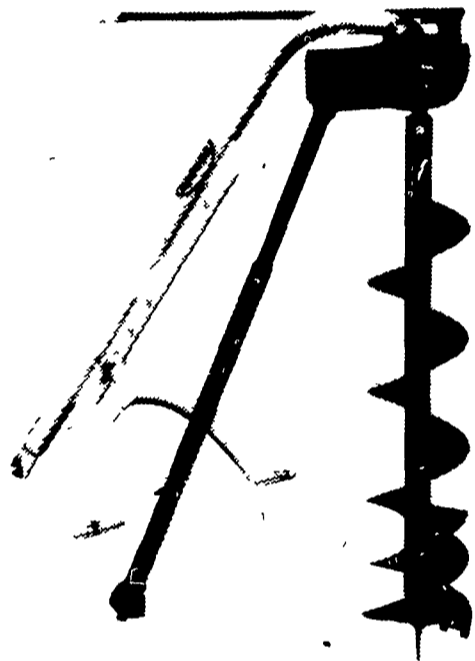

259⁹⁹

Reg 279 99 / SAVE 20 00
20226-157

9" Post Hole Digger

279⁹⁹

Reg 299 99 / SAVE 20.00
20227-157

12" Post Hole Digger

Three point hitch hookup, frame made of high strength steel tubing, gearbox has special alloy gears. Made to last.

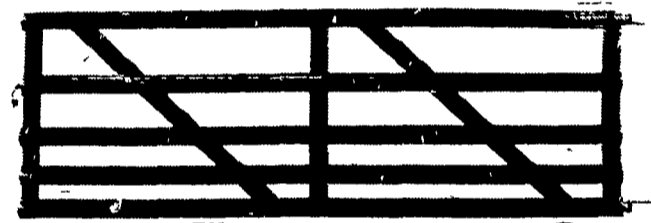

5 Panel Steel Gates

48" high gates with panels made of heavy 22 gauge galvanized steel. Gates are 4" shorter than listed to compensate for hinges and latch. Complete with screw hooks, hinges, and slide hatch.

10'
17646-253 Reg \$32 49 **SALE 27⁹⁹**

12'
17647-253 Reg \$36 59 **SALE 30⁹⁹**

14'
17676-253 Reg \$41 19 **SALE 34⁹⁹**

16'
17677-253 Reg \$44 69 **SALE 37⁹⁹**

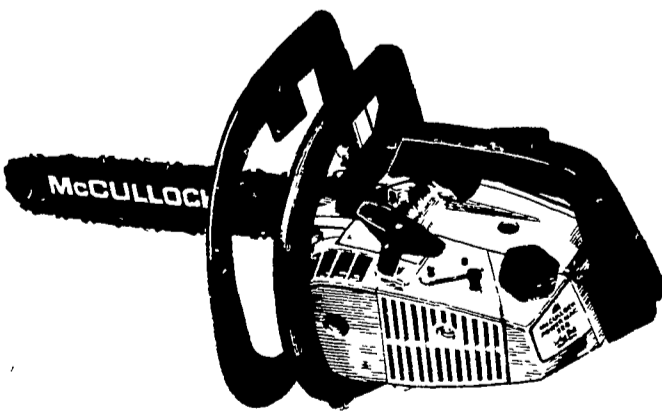

154⁹⁵

Reg 169 95 / SAVE 15.00
27948-098

McCulloch Power Mac 320

Features automatic chain sharpening, 2.1 cu in engine with solid state ignition, 16" sprocket tip bar, auto and manual chain oiling.

FARM & FAMILY CENTER

LANCASTER

1570 Manheim Pike, Hwy. 72 North
Ph: 717-569-0111

Sale Hours:

8 to 6:00 Monday - Thursday
8 to 6 Friday; 8 to 5 Saturday

CHAMBERSBURG

1351 Lincoln Way East
Ph: 717-264-8282

Sale Hours:

9 to 6 Monday - Thurs.
9-9 Friday
9-5 Saturday