

SAVE TIME AND MONEY MOVING CROPS

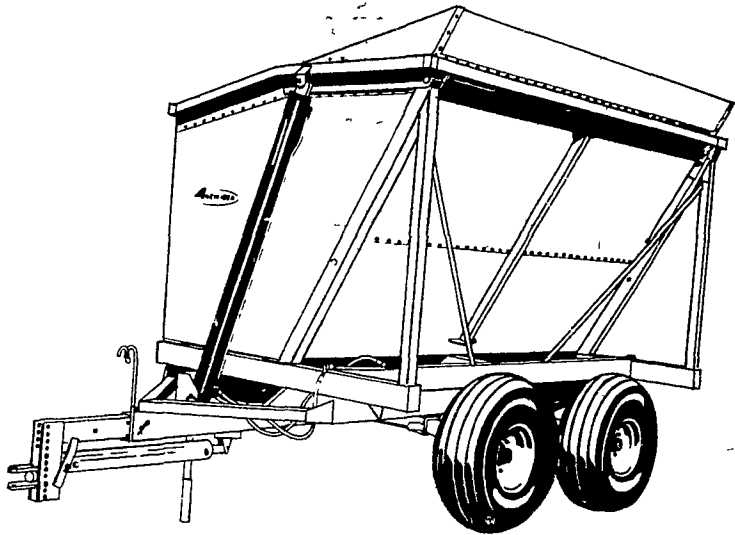

Whatever your tough hauling job may be, save time, labor and equipment costs with an Avco New Idea Hydraulic Dump Box.

Choose from two styles and three box sizes for rapid transfer and easy handling of material. New Idea offers three types of running gears: single, tandem or 4-wheel auto-steer. Ideal for seed corn, sweet corn, corn silage, haylage, shelled corn, small grains, sugar beets or dry chop materials. One all-purpose dump box will reduce your material transfer time and improve transport vehicle and driver efficiency.

YOU GET MORE HAY AND BETTER QUALITY HAY WITH THE MODEL 299 MOW/DITIONER

It does three jobs for you in a single pass — cuts a full 9 feet 3 inches, conditions and swaths or windrows — under just about any field condition.

The "Quick-Response" header flotation means less damage to guards and sickle on rough fields, and gives you more hay by maintaining a uniform stubble height.

Not only are you saving time, you're making higher quality hay with minimum damage to the valuable, nutrient-loaded leaves. The "Spiral Press" conditioning rolls run lug-on-lug to intermittently flatten stiff plant stems and is gently to tender leaves and short stems.

Maintenance is quick and simple, so you can spend more time in the field.

Put all of these things together, and you'll see why Mow/Ditioners are making sense to more and more farmers.

Rugged cutterbar gives you long life. The cutterbar is formed from one piece 3/8-inch steel and welded to the deck sheet to form a box section for maximum strength.

Adjustable windrow shields match drying and pickup width requirements. Convenient handles adjust either shield independently. A quick-adjust swath deflector slows and fluffs material for better air circulation and fast drying.

High-flotation tires distribute the weight evenly and because they are located up close to the machine center of gravity, they provide excellent balance and weight distribution to minimize sidedraft.

"Quick-Response" header flotation means uniform stubble height and minimum guard and sickle damage in each of six cutting positions. A unique pivot arrangement on the main frame, combined with the up-close position of the low profile, high flotation tires, quickly raises the cutterbar over obstacles. This design simply scissors the tongue and main assembly with the help of two adjustable springs.

Four-bar pickup reel lifts downed crop for a quick, clean cut, then sweeps it uniformly, butt first, into the conditioning rolls.

Wobble box knife drive gives fast cutting action for field travel — up to 8 mph.

Disc-type slip clutch provides complete drive line protection against shock and overloading.

Overrunning clutch protects both the gear box and the tractor from sudden deceleration.

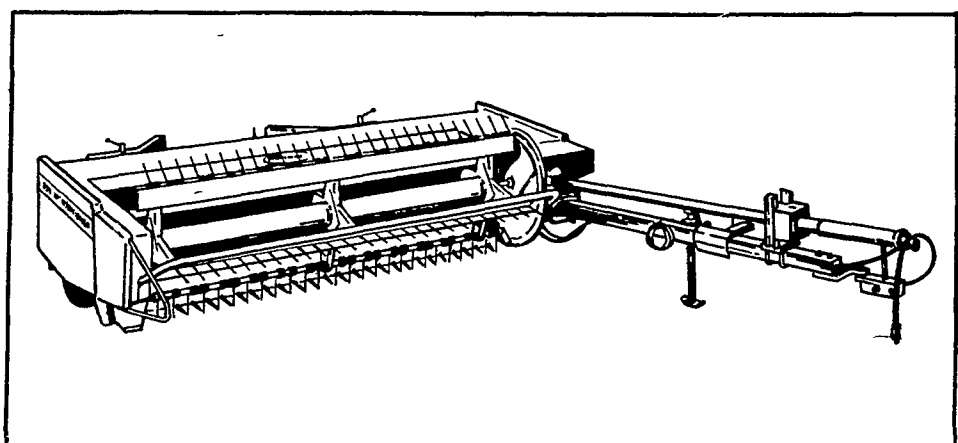
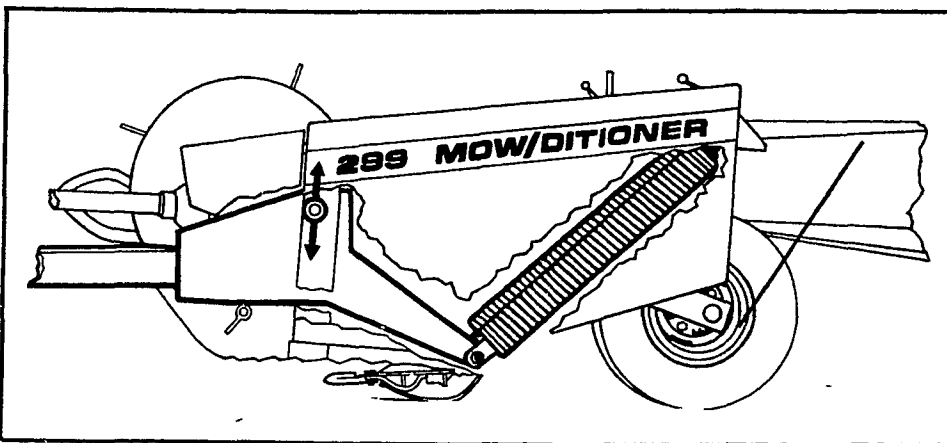

where the whole idea means better performance

SEE DEALERS BELOW AND ON OPPOSITE PAGE

WASHINGTON CO.

ALLISON BROS.
Main St.
Hickory, PA
412-356-2261

FIELDS IMPLEMENT STORE
P.O. Box 97
Eighty Four, PA
412-222-1154

ARMSTRONG CO.

SNYDERS IMPEMNT STORE
220 N. Grant Avenue
Kittanning, PA
412-543-2441

FAYETTE CO.

UNIONTOWN FARM EQ. CO.
P.O. Box 1030
Uniontown, PA
412-437-9851

INDIANA CO.

W.G. SATTERLEE, INC.
Main Street
Marion Center, PA
412-397-5533

BLAIRSVILLE FARM SERVICE, INC
R.D. 1, Box 625
Blairsville, PA
412-459-9600