

Berks Co. FFA holds PP contest

LEESPORT - The Berks County Future Farmers of America held their annual parliamentary procedure contest at the Agriculture Center. Twin Valley and Kutztown FFA chapters participated in the contest.

Twin Valley came out victorious by two points over Kutztown. Twin Valley consisted of president, Clarence Jennella; vice president, Howard Griest; secretary, Deb Ford; treasurer, Dan Mosteller; reporter, Doris Mast; sentinel, Lewis Kohl; chaplain, Steve Kearns; and junior advisor, Tom Kearns.

The Twin Valley chapter will receive \$75.

Kutztown consisted of president, Daryl Kunkel; vice president, Steve Angstadt; secretary, Sheryl Farber; treasurer, Randy Rabenold; reporter, Chris Bear; sentinel, Terry Klinsmith; chaplain, Rich Dietrich; and junior advisor, Dave Reigel. Kutztown will receive \$60. Both teams are eligible to compete in the area contest along with Schuylkill and Lebanon Counties.

Judges of the contest were Ken Heimbach and Tom Engle.

10 Red Rose supervisors honored



The above pictured Red Rose D.H.I.A. supervisors recently received the "Award of Merit" for their work in 1977. The "Award of Merit" is presented to those D.H.I.A. supervisors in Pennsylvania who meet employment qualifications and who excel in performance of their duties. From left

to right the supervisors are: Lee Landis, Narvon; Wilbur Houser, Lampeter; Harold Lindecamp, Peach Bottom; Harold Breneman, Strasburg; Floyd Zook, Strasburg; Moses Martin, Ephrata; Harold Probst, Bart; Dave Harnish, Quarryville; Jay Mylin, Manheim; and Ray Risser, Lancaster.

"Hitch your silo blower to a star"

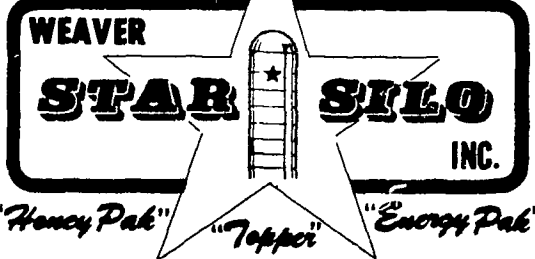

R.D. 4 MYERSTOWN, PA. 17067
CALL COLLECT 717-866-5708



WETMORE DIVISION

6, 8, 10, 11 & 12 TONS

WAGON GEARS

Designed with ample safety factor to meet load capacity. Built-in trailability for tractor speed roadability.



5, 6, and 8-bolt hubs and reinforced axles for greater structural strength. 72" tread to provide more stability. Bolter stakes adjustable from 38" to 42" to fit any hauling job.



Short turn radius and front steer for easy maneuverability. Tapered roller bearings to reduce friction and prolong life of parts.

A FULL LINE OF RUNNING GEARS, RUGGEDLY BUILT AND DESIGNED FOR FORAGE BOX, GRAVITY BOX, FERTILIZER TANK, AND ANY OTHER HAULING WORK IN YOUR FARM OR INDUSTRY.

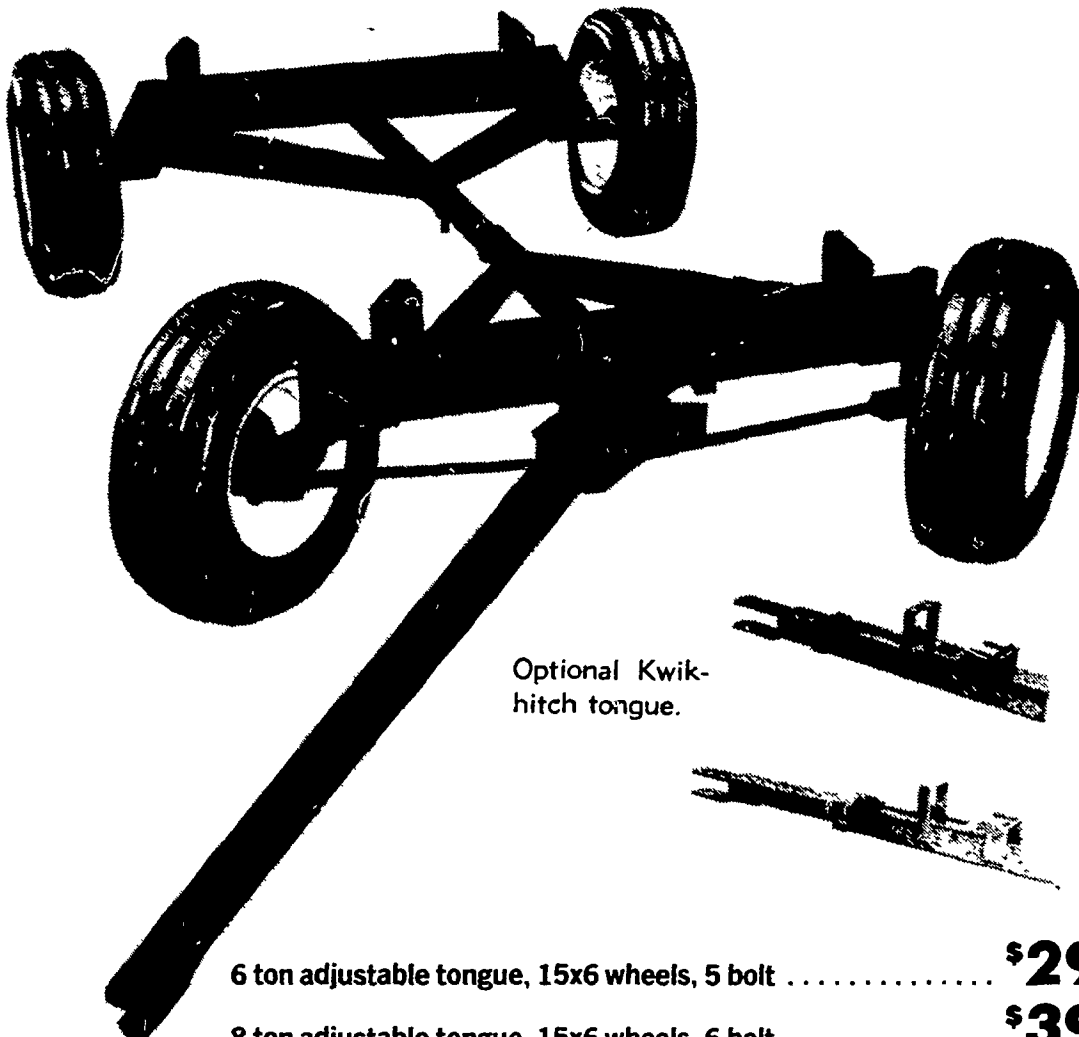

Optional Kwik-hitch tongue.

- 6 ton adjustable tongue, 15x6 wheels, 5 bolt \$295
- 8 ton adjustable tongue, 15x6 wheels, 6 bolt \$395
- 10 ton quick hitch tongue, 15x8 wheels, 6 bolt \$495
- 11 ton tandem quick hitch tongue, 15x8 wheels, 6 bolt \$695
- 12 ton quick hitch tongue, 15x10 wheels, 8 bolt \$695

Officers named

ALBURTIS - The Eastern Berks 4-H Dairy Club held their reorganization meeting recently.

Officers elected included: Wendy Shaw, president; Helen Seidel, vice president; Ruth Schuler, secretary; Nancy Latshaw, treasurer and news reporter; and Scott Hausman, game leader.

During the meeting, F.M. Brown's and Sons, Inc. gave a presentation on successful methods of raising a healthy calf.

The next meeting will be held on May 12 at the home of Wendy and Steve Shaw.

A recent survey conducted by the National Association of Realtors revealed that the median age of real estate firms surveyed was nine years. Firms in business the longest generally were located in the Northeast. The West has the largest share of newer firms.

COMPLETE FARM PAINTING



We Use Quality PAINT AERIAL LADDER EQUIPMENT

- Modern and Efficient Method
- Reasonable Prices
- Spray On and Brush In Method
- Sandblasting If Necessary

FOR FREE ESTIMATES WRITE

ESH SPRAY PAINTING

(Daniel S. Esh, C. Ralph Miller) SPRAY-ON AND BRUSH-IN PAINTER Box 350A Ronks, PA 17572 or call this number 717-687-9155 INDUSTRIAL COMMERCIAL RESIDENTIAL

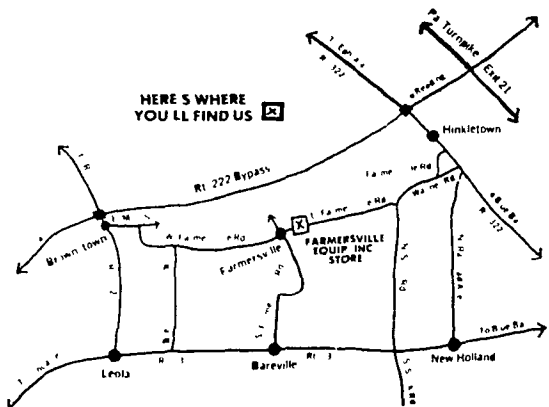

FARMERSVILLE EQUIPMENT

INC.

RD 4, Ephrata, PA

717-354-4271

HOURS

Mon., Tues., Wed., Fri. - 7:30-5:30
Thurs. - 7:30-9:00
Sat. - 7:30-3:00