

# PYRAMID CHORE-TIME MID CAGE LAYER SYSTEM

## ★ LESS BIRD STRESS

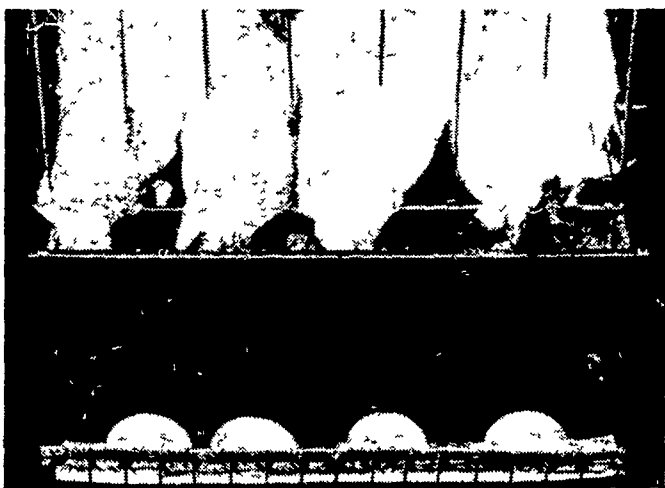

The system has been designed for bird comfort! Each bird has her place at the feed trough. Each has easy access to water. Obstruction to light and the flow of air have been greatly reduced, providing more uniform ventilation and lighting for every bird. Combined with Chore-Time's automatically controlled air inletting system, you get a layer house environment designed for bird comfort and the resulting better production.

## ★ NO DROPPING BOARD SCRAPER

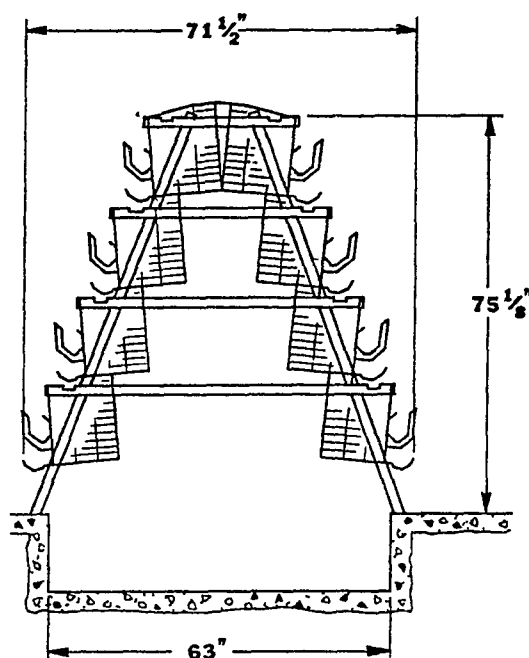

It requires no dropping boards or scrapers. It is available in either three-hi or four-hi models, with the four-hi configuration providing the same bird density per square foot of building space as do conventional three-hi systems, without increasing building costs.

## ★ LESS CHANCE OF CHECKS & CRACKS

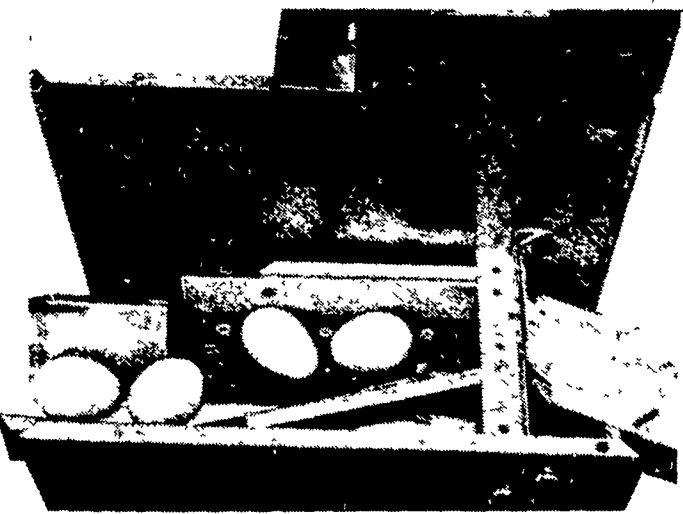

With a shallow cage design we were able to reduce the cage slope for more gentle roll-out. Eggs don't travel as far to the belt and once on the belt, move single file down the entire cage row. They are then transferred, one at a time, into the newly designed Soft Touch II "de-eggscalators" and onto the cross conveyor.

## ★ MINIMIZES FEED WASTE

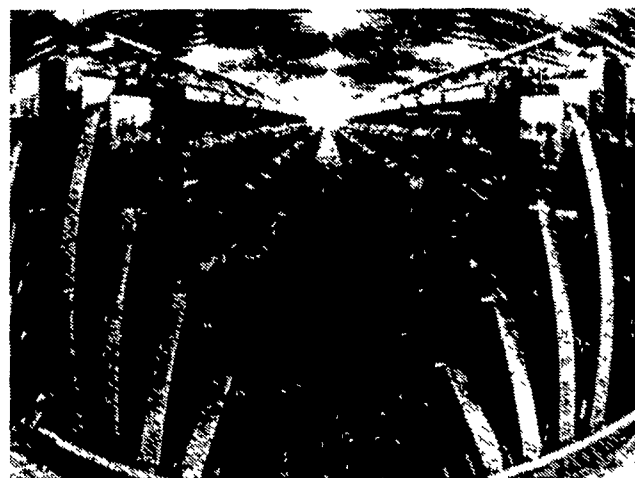

Not only the physical shape of the feed trough, but the operation of the feeder has been engineered to reduce feed waste. The trough shape cuts down on feed loss from "raking" and "billing," while the feeder has been specifically designed for Chore-Time's programmed and performance feeding concept.

"PYRAMID . . . AN EGG PRODUCTION SYSTEM DESIGNED FOR A CHANGING INDUSTRY"

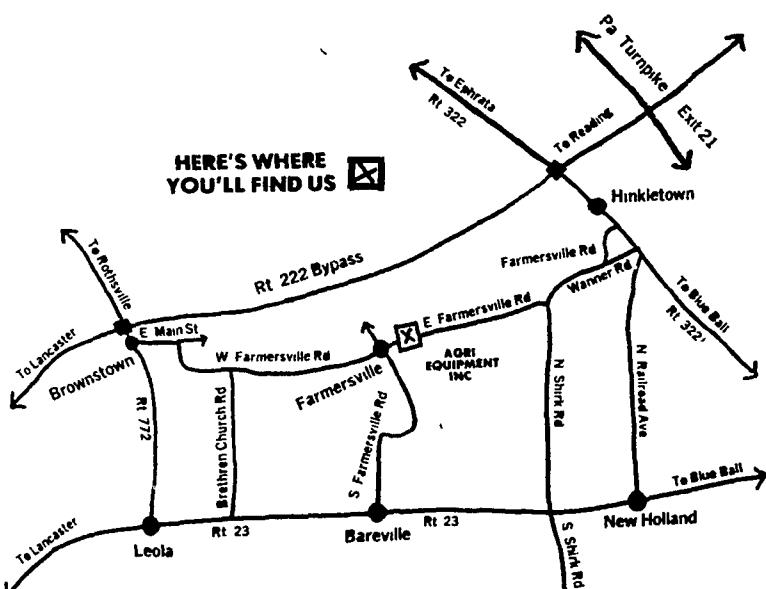

**AGRI-EQUIPMENT, INC. OFFERS COMPLETE**  
• SALES • INSTALLATION • SERVICE •



**CATTLE - HOG - POULTRY EQUIPMENT**

NEW STORE HOURS: MON., TUES., WED., FRI. 7:30-5:30  
THURS. 7:30-9:00; SAT. 7:30-3:00