

LANCASTER COUNTY

3.4 ACRES with frame Cape Cod dwelling, featuring entry, living room, dining room, kitchen, 1½ baths, 3 or 4 bedrooms, utility room off kitchen, enclosed porch, full concreted basement. Also 40x20 barn with extension and 2 car garage. Large shade trees, privacy and road frontage. Large shade trees, privacy and road frontage. Bart Twp.

4.0 ACRES with 2½ story frame home featuring modern kitchen, dining room, living room, 1 modern bath, 4 bedrooms, family room, 3 fireplaces and concreted basement. Also 40x60 barn, corn barn, machine shed and 4 car garage. Plenty of mature shrubs and trees. Fulton Twp.

YORK COUNTY

139 ACRES grain farm in high state of cultivation, Chester silt loam soil, some of the best laying farm ground in Southern York Co. with 6,854 ft. of hard road frontage. Remodeled frame house, frame barn and other out buildings in excellent condition and setting well back from main road among shade trees. Spring and pond in meadow, some woods, approx. 110 acres tillable. Buy all or part. Owner will finance to qualified buyer. Chanceford Twp.

215 West Fourth Street

Emory D. WAGNER Co. Quarryville, Pa. 17566

Realtors (717) 786-2131 or 786-3020

REAL ESTATE

REAL ESTATE

EXCELLENT BARN with 78 ties, 2 unloaders and cleaner on 289 acre dairy, gravelly silt loam soil. Very nice 8 room home, oil heat. 78 Holstein milkers, tractors and machinery. \$260,000.

WOULD COST \$200,000 TO REPLACE new 127 tie barn in Central N.Y.S., 28x40 wing for 60 head young stock, DeLaval pipeline, 4 concrete silos. 425 acres, deep, well-drained loams. 4 good homes. Asking \$400,000.

STOCKED AND EQUIPPED 289 acre dairy, 200 tillable. 60 cow pipeline barn, cleaner, unloader. Also 2nd barn with cleaner. Fine 8 room home. Hook up for trailer. 60 milkers, young stock, 4 tractors, good equipment. \$192,500.

WIDOW MUST SELL 72 acre farm. Large barn for about 65 head, new wing, 16x40 silo. Good 9 room home, 1½ baths, oil heat. Asks \$49,900 all offers submitted.

ALL KINDS OF FARM PROPERTIES, FREE LISTS.



REALTOR

WIMPLE REALTORS SLOANVILLE, N.Y.

518-875-6355

REAL ESTATE

REAL ESTATE

310 acres all modern dairy and hog farm, 50 tie stall barn and other buildings. Most buildings are less than 5 years old Well kept, recently remodeled older 2 story home. Terms available. Owner selling due to health Located in SE Minnesota.

305 acres dairy or beef farm, new home, machine shed and silo. Well drained land Also located in SE Minnesota. Terms available.

Contact:

BUYRITE REALTY INC.

Dodge Center
507-374-6328
Jerry Dallmann

Rochester
507-288-6909
Lydon Gesselle

SOUTH CENTRAL PENNSYLVANIA FARMS

CUMBERLAND COUNTY

DAIRY (Newville)
110 Acre limestone, 93 free stalls, double 5 herringbone parlor, 600 gal. tank, 3 concrete stave silos (2000 ton), large 8 room brick house, center hallway, open staircase.

GENERAL (Carlisle)
87 Acre limestone, no barn, solid modern 7 room brick house.

DAIRY (Carlisle Springs)
40 Acres, shale, gently rolling, large bank barn with 32 stanchions, 2 silos, charming modern frame house, beautiful never failing stream.

FRANKLIN COUNTY

DAIRY (Orrstown)
70 Acres, shale, 39 tie stalls, stable cleaners, pipeline, bulk tank, 3 silos w/loaders, comfortable log and aluminum house, large farm pond and creek.

PERRY COUNTY

GENERAL (Blain)
122 acres, highly productive, gently rolling (110 tillable), large bank barn, frame house and other out buildings, 2 strong springs bordering Shermans creek

If you are thinking about selling your farm, give us a call for a "No Obligation Appraisal".

John B. Niesley, Farm Representative
Home Phone 717-243-7575

GEORGE L. EBENER

139 West High Street
Carlisle, PA
Phone 717-243-6195

HERE'S YOUR RIGHT CONNECTION

IH 45 VIBRA SHANK CULTIVATOR

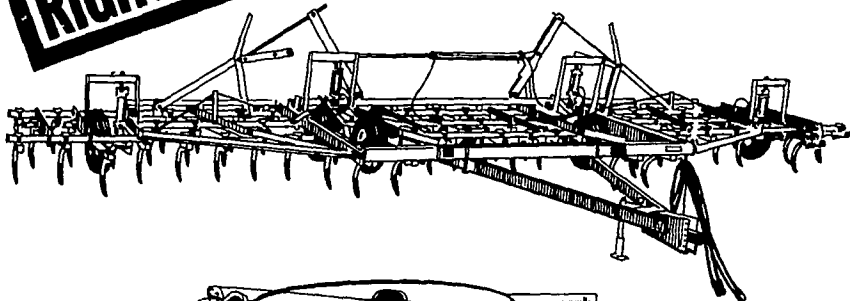

SPECIAL PRICE THIS WEEK!

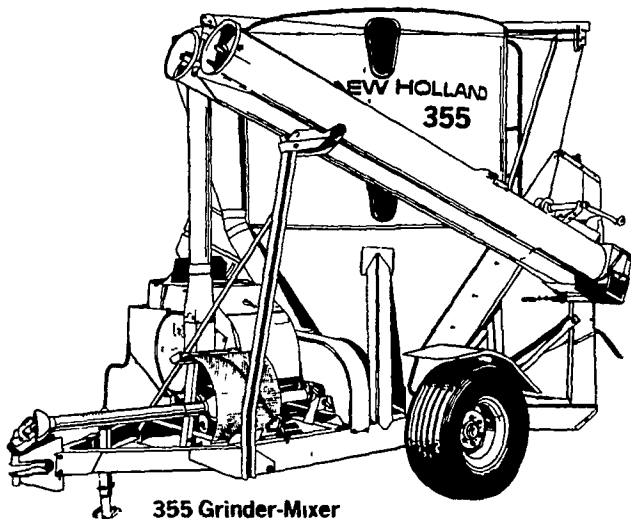

355 Grinder-Mixer

Good Selection Of Used Forage Equipment

- IH 650 Harvester - 2 row head
- IH 50 Harvester - 2 row head
- IH 55 Harvester, 2 row head
- NH 717 Harvester - 2 row head
- NH 23 Blower - Real Nice
- Fox High Capacity Blower

JUST TRADED

**NEW IDEA 325
2 ROW NARROW PICKER
WITH 318 GRINDER.
USED ONLY 100 ACRES.**

WAIVER OF FINANCE ON NEW AND USED EQUIPMENT

- ★ FORAGE EQUIPMENT TIL SEPTEMBER 1, 1978
- ★ HAY EQUIPMENT TIL JUNE 1, 1978
- ★ TRACTORS TIL MARCH 1, 1978

- JD 720 Tractor
- IH 1066 w/cab, 20.8x38 tires
- Bear Cat Grinder-Mixer
- MF Plow, 3-14"
- John Deere #2 Tedder
- Fox High Capacity Blower
- Farmall 806 Diesel
- IH 315 Combine, 2-row head, 13 ft. platform

- Gehl Haybine
- NH 469 Haybine
- NH 352 Grinder-Mixer
- IH 370 Disc, 12 ft.
- IH 650 Harvester, 2-row narrow
- IH 700 5-bot. plow
- NH 320 Baler w-thrasher excellent
- NH 1469 Haybine, self propelled w-Ford engine
- Gehl Blowers

- IH 990 Haybine
- JD 480 Haybine
- IH 50 Harvester
- NH 717 Harvester, 2 row
- IH 710 4-bottom Plow
- IH 160 Bu. Spreader
- NH 145 Bu. Tank Spreader
- NH 518 Spreader
- Brillion 12 ft Transport Harrow

SEE US AT THE MANHEIM FARM SHOW - OCT. 5-6-7

MESSICK

THE RIGHT CONNECTION

FARM EQUIPMENT INC.

2750 N. MARKET STREET PHONE 367-1319 ELIZABETHTOWN, PA.
JOHN KREIDER — HOME 367-6039 WARREN SPICKLER — HOME 653-4560

119 ACRE DAIRY FARM
80 oak-partitioned free stalls divided in two buildings. Barn with stanchions to stable 32 cows for milking. Large milkhouse. Located away from metropolitan area and is readily adaptable to hog operation. Old log house renovated with 4 bedrooms, living room, dining room, kitchen, bath and concreted basement. 60 tillable...47 pasture and 12 wooded. Large stream borders farm. Adjoining land can be rented, only \$1,000 per acre. Also second home can be purchased with this property.

95 ACRE FARM...
Beef and hog operation, approx. 55 tillable, balance pasture and woods with stream, 2 harvestores and bunk feeder. Large barn, large log house very tastefully remodeled, 2½ baths, very nice kitchen, plus many extras. Spring house, private setting, good location near Penn Nat. Race Track. Farm also has other possibilities.

22 ACRE FARM - DAUPHIN CO...
11 acres tillable, 11 acres pasture and wooded. Quiet along back road near the mountains. Stream flows through part of the farm and another borders on south side. Nice small barn, 2 car garage, log house remodeled with 3 bedrooms, living room, kitchen and bath.

For more information, call and ask for either:
JESSE ZIEGLER - Evenings (717) 838-1257
JUDY ROGOZINSKI - Evenings (717) 859-1384



LIST YOUR FARM WITH US!

We have a professional farm agent and with ERA we now have national exposure.

SLAUGH FAGAN AND ASSOCIATES

Realtors/Insurers (717) 733-6556