

REAL ESTATE

REAL ESTATE

REAL ESTATE

REAL ESTATE

REAL ESTATE

REAL ESTATE

Sale by Owner - modern farm Juniata County. 122 free stalls, 40 barn with 6 unit silo, 2 Harvestors, one silo, 120 ft. bunk, 12' manure pit - aluminum house. Owner financing available. Phone 717-4896.

Sale - 193 acre farm, 150 acres, Juniata County. Phone 717-898-8441 Realtor.

Pa. farms: 160 acres, 140 acres, very clean, owner finance, asking \$100,000. Also 15 acres good buildings, Chambersburg - 200 acres with large home, etc., to settle estate. 200 acres, or dairy with lovely view, \$150,000.00. Van Cleve Estate, New Oxford, Pa. Phone 717-624-8201

Sale - 126 acre farm, house and outside bldgs. Located 2 1/2 miles Le Raysville. Wanted bidders. Owner reserves right to object or reject bids. Simon Yoder, Le Raysville, Pa. 18853.

DALHART, TEXAS - A GREAT PLACE TO GROW CROPS AND KIDS. Buy irrigated farmland starting in the \$750 per acre price range and grow 150-200 bushel corn. Pay 50 cents-\$1.00 property tax per acre. NO STATE INCOME TAX. Mild winters, 178 day growing season, and excellent local grain market. Friendly community and good school system. Free brochures available: Call collect day or night. (806) 249-5613, (806) 249-4000. Mike Justice & Associates, Box 501, Dalhart, Texas 79022.

FOR SALE - 81-acre steer feeding farm, Brecknock Township, Berks County. Large 10-room stone home with 2 full baths plus 2 powder rooms. Wall to wall carpeting throughout house. Newly remodeled. 3-room guest house w-fireplace. Large bank barn 40'x100', feed lot macadamized and fenced. A-frame office building 24'x30'. 72 acres of cropland, 9 acres of pasture with stream and pond. For more information call - 717-393-3921 - Lancaster Production Credit Association, 411 West Roseville Road, Lancaster, Pa. 17604

For Sale - 250 acres of rich flat land, 190 tillable, 50 acres in corn. New 180' barn, new 48 x 72 addition for machinery and 28 heifer stanchions. Barn cleaner, pipe line, 20 x 60 and 20 x 45 concrete silos and unloaders, automatic feeder in barn for corn and haylage. Large 12 room house with central heating, garage and tool shed, large machine shed, 85 head. Buy stocked and equipped or bare. In Mennonite area. Lowville, 315-376-2518.

**TIOGA CO. BY OWNER:**  
150 plus acres, ideal for beef, hogs, or horses. 2 barns (1 barn remodeled for hogs) and other out buildings. 30 acres of timber, large 9 room house in excellent condition, has new kitchen, fully insulated, heat with wood or electric, private setting. Taxes are \$431. Price \$79,500.  
Call after 4:30 PM for appointment  
**717-549-5882**

140 acre farm, modern house, automated feed lot, glass-lined silo, modern farm buildings and bank barn. Port Royal, Juniata County. PH: 717-527-4093.

**FARMS FOR SALE COLUMBIA COUNTY**  
Beef farm, 130 acres, new barn 48 x 200; also bank barn and good two-story home and stream.  
67 acre dairy farm, new 50 stall barn, two silos, additional rental land adjoining.  
Call  
Wandell Real Estate  
Phone 717-784-8172

**WANTED**  
Farm with retail milk jug operation. Send response to P. O. Box 266C, c-o Lancaster Farming Newspaper, Lititz, Pa. 17543

For Sale - building lots - 1 1/2 to 2 1/2 acre lots in Juniata County. Also, 10 acre lots - Snyder County - road frontage - Ph: 717-444-3682

Farm for sale by owner, St. Lawrence Co., New York. 175 acres, 2 barns, silo, Gleaner, Mow elevator, oversize one bay garage, 4 bay garage, 70 ft. equipment shed, 4 bedroom home, forced air heat, new kitchen, new bath, 16 x 30' living room with fireplace, wall to wall carpeting, aluminum storm windows and screens, black top road, and school bus at door. \$75,000.  
**BILL MULLAN**  
RT. 1  
Richville, NY  
Phone 315-287-1848

**FARMS FOR SALE NEW YORK**  
**FARMS DAIRY-GRAIN-LIVESTOCK 100 to 1000 ACRES BIG FIELDS RICH SOILS RURAL REALTY**  
Venice Center, NY 13161  
CALL TOLL FREE: New York 800-962-1480 Elsewhere 800-448-4511

**FOR SALE BERKS COUNTY**  
15 miles north of Reading, 36 acres, springs, barn, out buildings, 10 room house, new roof, windows, aluminum siding, approximately 400 ft. frontage - \$75,000  
Call 215-926-4615 (owner)

**HORNING FARM AGENCY, INC.**  
Main Street Morgantown, Pa. 215-286-5183  
**Nittany Valley:**  
142 acres, 80 tillable, 41 woodland, balance pasture, mountain spring, 7 room dwelling, 37.5 x 60 steel implement shed, no barn, asking \$125,700.  
155 acres 119 tillable, large meadow with stream, 7 room brick dwelling, bank barn with 34 stanchions, 2 silos, 16 x 55 and 12 x 55, 2 large steel sheds, mountain spring supplies dwelling and barn. Make offer.  
**Perry County:**  
Pick your farm today— 700 acres plus, 500 tillable, 4 dwellings, 3 barns, lots of creek frontage.  
Roy E. Haller, Agent  
215-484-4844

New Dairy Farm, Strasburg, 40 acres, 26 stanchions, bulk milk tank, 12 x 60 silo, two story, 8rm house. Possession early spring, for details ask for Ken.  
Stream and pasture, Strasburg area. Here is a good clean 2 1/2 story house with lots of green grass around, modern eat in kitchen (new cabinets), a cozy livingroom, 3 bedrooms and bath, closed in and paneled sun porch, even a new furnace. There is a good barn for horses and other livestock, plenty of fencing, meadow and stream. 5 acres includes some fruit trees. \$60,000, ask for John N. Landis.  
New listing 90 mi. North of Lancaster, Northumberland Co. A fantastic opportunity to own a completely remodeled home on 69 acres with two never-failing springs, large farm pond, horse corral, and a gorgeous view of the mountains. \$77,500.  
Call  
**Town & Country REALTY**  
717-299-4885  
250 North Duke Street Lancaster, Pa.

**CENTRAL PA:** 52 acres of woodland near State College. Has been surveyed in 10 acres parcels with roads cut in to each tract. There are several springs on this mountaintop land and is adjacent to 3000 acres of Game Land. Also only minutes from Joseph Sayer Dam. Excellent hunting, fishing and boating only a short distance from I-80. \$40,000 for all 52 acres or \$9000 for a 10 acre parcel.  
**SNYDER CO:** a modern dairy operation with 3 silos, including 2 Harvestors, a good home, new 2500 sf equipment storage shed, milking parlor, bulk tank and a free stall barn. 104 acres of land. Owner will help with financing for a qualified buyer.  
**THE BOWEN AGENCY**  
"PHOTOS BY WIRE"  
22 NORTH MARKET STREET SELINGROVE, PA 17870  
717-374-2165  
Evenings call Realtor Assoc., John Arnold 717-837-0061 or Phil Graybill 717-374-8038 Paul Kuhu 717-374-4144

HERE'S YOUR RIGHT CONNECTION

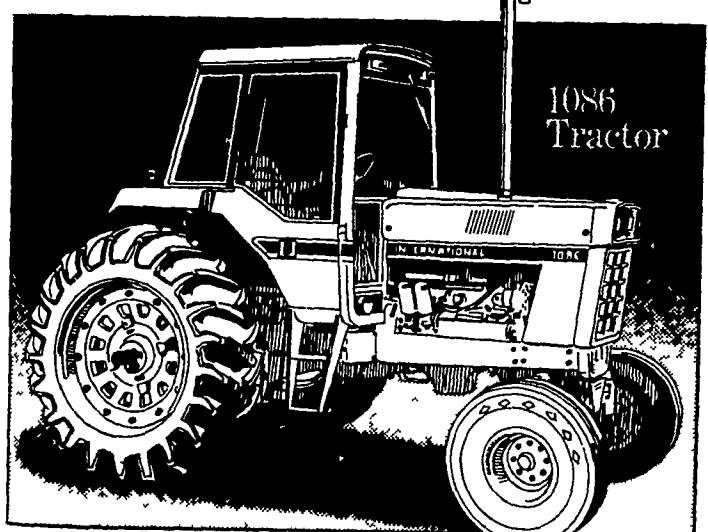

FOR BIG POWER AND COMFORT  
IH 1086 TRACTOR

**WAIVER OF FINANCE MANURE SPREADERS & GRINDER MIXERS TILL OCT. 1, 1977 FORAGE EQUIPMENT TILL SEPT. 1, 1977**

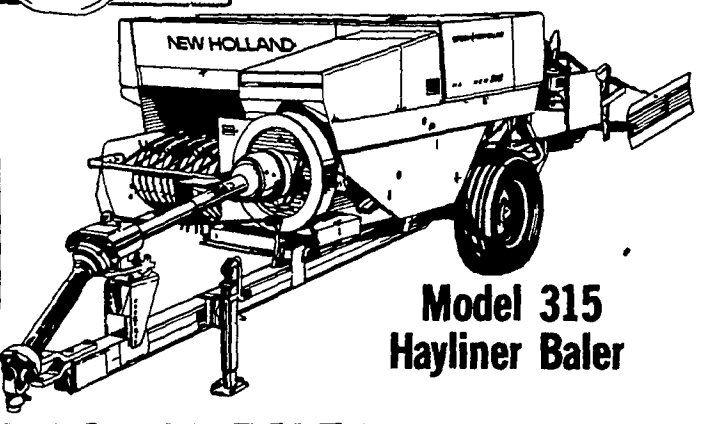

Model 315 Hayliner Baler

**RENT OR BUY NH 850 ROUND BALER**

**M.H. 82 COMBINE, 12 FT. PLATFORM, 2 ROW CORN HEAD, REAL NICE**

- |                                     |                                    |                                 |
|-------------------------------------|------------------------------------|---------------------------------|
| Farmall 806 - new paint - real nice | Int. Model 710 4 Bot. Plow         | 300 Gal. Waish Sprayer          |
| IH 574 Diesel                       | Int. Model 700 5 Bot. Plow         | 5 ft. Rotary Cutter             |
| IH 1066 w/cab, 20.8x38 tires        | Farmhand Wheel Rake                | IH 50 Harvester                 |
| N.H. 68 Baler                       | IH 160 Bu. Spreader                | NH 1717 Harvester, 2-row        |
| N.H. 352 Grinder-Mixer              | NH 145 Bu. Tank Spreader           | Gehl Blower, Hi-throw, Model 88 |
| Bear Cat Grinder Mixer              | IH 650 Harvester, 2-row and pickup | IH 370 Disk, 12 ft.             |
| MF Plow 3-14"                       | NH 330 Spreader                    | John Deere Disk, 12 ft.         |
| John Deere #2 Tedder                | NH 1469 Haybine - Excellent        | Fox Blower                      |

**MESSICK FARM EQUIPMENT INC.** THE RIGHT CONNECTION  
2750 N. MARKET STREET PHONE 367-1319 ELIZABETHTOWN, PA.  
JOHN KREIDER HOME 367-6039 WARREN SPICKLER HOME 653-4560

**FOR RENT**  
8 room house with 1 1/2 baths and laundry room, large 3 car garage can also be used for storage or work shop, large plot of ground for garden or truck patch. Located just East of Lancaster on Route 340. Asking \$300. per month.  
Call John Fisher 215-269-2727