

Real Estate

Real Estate

Real Estate

Real Estate

**FOR SALE - POULTRY FARM IN OPERATION**

16,000-18,000 pullets or  
36,000-40,000 broilers

On approximately 5 acres with stream in Southern York County.

Easy access to I-83. 4 bedroom home with bath, kitchen and dining area, living room. Three horse stable, 1 other out building.

Ph: 717-741-1389

(home phone, anytime)

PH: 717-244-6425

(Mon, Tues. & Sat., 10-5 PM)  
(Wed. Thurs. Fri. 10-9 PM)

**DAIRY FARMS**

320 acres, 160 tillable. 53 stanchion barn with pipeline. 2 silos - one 80 ft. Garage and tool shed. Home with fireplace.

300 acres, 250 tillable. 60 stall barn plus stalls for heifers. 2 box stalls. Covered barn cleaner room. 2 silos. Mow conveyor. Large house with combination furnace. Owner financed.

235 acres, 170 tillable. New 80 tie barn with pipeline. Large silo. Covered cleaner room. Mow conveyor. New calf barn. New 40 x 100 tool shed. Nice 2 bath house. Stocked and equipped.

Over 300 acres, 250 tillable. 100 cow barn with pipeline. 1000 gallon tank. Covered cleaner room. 2 silos. 2 mow conveyors. Tool shed. Large corn crib. Nice house.

This is just a sample of our listings. Please call or write for our free catalog.

**FARM SPECIALIST REALTY, INC.**

1116 Arsenal Street  
Watertown, New York 13601  
315-782-2270

242 A 60 stall Harvestore, immaculate home; Also tenant house.

120 A 56 stalls, silo, 3 homes, only \$145,000.

226 A 68 stalls, 3 barns, 3 silos, immaculate stone mansion, 3 fireplaces, also nice home for manager, \$250,000

32 A Lancaster County, excellent buildings, horse barn, pasture with creek

104 A 39 stalls, 2 nice homes, development possibility

10 A nice creek, trees, no buildings.

**BLUE BALL REALTY**

Blue Ball, Pa.  
Phone: 717-354-4536

PREMIUM CASH CROP FARM, 1,220 acres, 1,020 tillable, very large fields. 7 good houses. 50,000 bushel grain storage, metal bins, silo, excellent dryer. 140x40 pole barn.

EXCELLENT DAIRY BUY! 268 acres Otsego County. 46 cow barn, cleaner, unloader, new machine shed. Ranch home with nice setting and lawns. 34 milkers, young stock, 3 tractors, equipment. \$110,000.

71 COW BARN with pipeline, cleaner and unloader on 177 acre dairy. 5 room mobile home with basement. \$79,900.

TRUCK FARMERS! Rare offering of 275 acres with best soils and growing season. This land has never needed nitrogen! Warehouses.



**WIMPLE REALTORS,  
SLOANSVILLE, N.Y.**

REALTOR

518-875-6355.

Real Estate

Real Estate

**FARMS**

All sizes and types  
Finger Lakes Area

**J. R. ALLEN REALTOR**

Dundee, N.Y. 14837  
607-292-3180



**NEW YORK DAIRY FARM**

400 acres, 250 tillable. Stream through property. 60 stanchions. 2 box stalls. Calf barn. 625 gallon bulk tank and dumping station. 16 x 48 and new 18 x 56 silo put up after picture was taken. Storage shed. 2 bay garage shop. 1 1/2 story 4 bedroom house. Excellent cared-for line of equipment. Good young dairy. All for \$165,000.

**FARM SPECIALIST REALTY, INC.**

1116 Arsenal Street  
Watertown, New York 13601  
315-782-2270

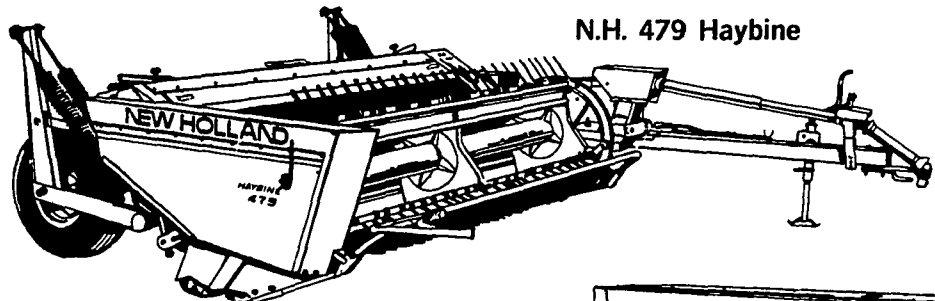

N.H. 479 Haybine

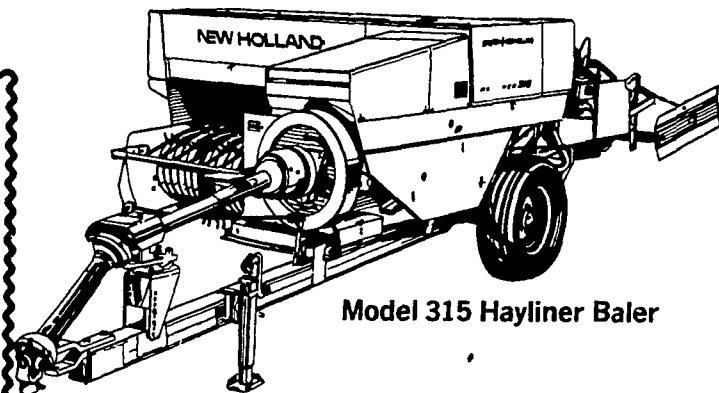

Model 315 Hayliner Baler

**WAIVER OF FINANCE**  
Hay Equipment - June 1, 1977  
Manure Spreader - Aug. 1, 1977  
Grinder-Mixers - Aug 1, 1977  
Forage Equipment -  
Sept 1, 1977

IH 806 Diesel  
IH 574 Diesel  
IH 1066 w/cab, 20.8x38 tires  
IH 460 Utility  
Farmall Cub w/thrower  
Ford 8N N.H. 273 Baler w/thrower  
N.H. 68 Baler  
N.H. Super 69 Baler w/thrower  
Dunham Culli-mulcher  
NH 352 Grinder-Mixer  
NH 275 Baler with thrower

Bear Cat Grinder Mixer  
Gehl Haybine  
John Deere #2 Tedder  
Farmhand Wheel Rake  
I.H. 160 Bu. Spreader  
N.H. 145 Bu. Tank Spreader  
N.I. 2 Row Picker model 325 with  
327 Husking bed, also with  
grinder model 318  
IH 650 Harvester, 2-row and  
pickup

I.H. 50 Harvester  
N.H. 717 Harvester, 2-row  
Fox Blower  
Gehl Blower  
IH 370 Disk, 12 ft.  
John Deere Disk, 12 ft.  
IH 370 Disk, 10 ft.  
N H. 30 Ft Elevator

**SPECIAL PRICE**

**NEW HOLLAND 1890 SELF-PROPELLED HARVESTER**  
WITH 3 ROW HEAD AND WINDROW HEAD, 150 HOURS,  
EXCELLENT CONDITION

**MESSICK**

**FARM EQUIPMENT INC.**

2750 N. MARKET STREET PHONE 367-1319 ELIZABETHTOWN, PA.  
JOHN KREIDER HOME 367-6039 WARREN SPICKLER HOME 653-4560

Farmette: 30 Acres, 10 tillable, bal. pasture & woods, with pond, large 3 story frame house, modern kitchen, fire place in den, oil hot air heat, porch completely around house, new roof. large bank barn, 2 barn floors, in excellent repair, located only 2 miles from Pa. Turnpike in Fulton Co., Pa. Priced to sell quick at only \$59,000. Water is from spring.

Farmette: 41.53 acres, only 3 miles from Fulton Co. seat, 7 acres tillable, bal. woodland with ideal homesites avail. Spring water on this property, 2 story, 3 bedroom house, no modern conveniences except elect. Small concrete block bran. Ideal for summer home horse farm or beef cattle \$36,000. will take it.

Homesite acreages, average from 6 A plots up to 28 acres. This farm subdivided, 1 plot with frame barn, macadam road frontage on many, others has township frontage, stream running through many of these plots, excellent rural farming view. Excellent hunting and fishing. Stake your claim quick, these will not last long. Only 15 minute drive from Pa. turnpike and I-70 in lower Franklin Co., Pa.

**STROUT REALTY, INC.**

L. Wayne St. Clair, Broker  
398 North Main St.  
Mercersburg, Pa. 17236  
Phone 717-328-2180 or  
717-328-3788

Sunbury - 123 Acres Beef & Hog Farm. Hog feeder barn for 250 hogs w-bins, silos 14x40, grain dryer, (2) 3,500 capacity bins, 40 stanchions, loafing barn, real nice 12 room house, farm pond, only \$135,000.

110 A. General Farm, 1 farm house, 1 immaculate ranch house w-fireplace.

80 Acre General with Mobile Home Park. Montour Co. 152 Acre General \$139,000. Clinton Co.

Nittany Valley - 146 Acre General Farm, Limestone and Hagerstown soil \$100,000. Clinton Co. Spring Possession. Offers Accepted.

73 Acres, Mountain stream, trout pond \$78,000. Clinton Co.

56 Acre General \$60,000. Northumberland Co.

80 Acres, no buildings, \$80,000. Columbia Co.

**NORTHUMBERLAND COUNTY**  
70 Acre Dairy, 16 stanchions, Rt. 54 between Turbotville & Montgomery. Spring Possession. Offers Accepted.

60 A. General, 58 Acre tillable \$70,000.

67 A. General, 50 A. tilled. \$85,000 (Millersburg North)

**WITWER REAL ESTATE**

Paul Martin, Agent  
Lewisburg 717-524-4580  
Merle Miller, Agent 717-285-3360  
Joe Zimmerman, Agent 215-267-7963

Ephrata, Pa. Office 717-733-4138