

UEP supports target price formula

WASHINGTON, D.C. - In testimony on March 2 before the House Committee on Agriculture, Mike Hirth, Chairman of the United Egg Producers Feed Grain

Committee, called for commodity target prices in the new Farm Bill to be pegged at about 80 per cent of the cost of production and requested that finished or processed agricultural products be encouraged under P.L. 480 programs.

Hirth was among 12 witnesses who appeared before the Committee concerning wheat and feed grain issues. His testimony was along similar lines as that presented by UEP to the Senate Agriculture Committee during 1975 hearings on target prices.

Hirth noted that the key to the target price concept was what constitutes the farmers' cost of production. For this purpose, he suggested the House Committee adopt the methods and formula of the Senate Committee on Agriculture, Nutrition and Forestry which was announced January 18 when Sen. Herman Talmadge introduced his proposed Agriculture and Consumer Protection Act of 1977 (S.275). In that formula, Hirth noted that the Committee based land values on a 35-year average of land acquisition costs. He said the Congressional Budget Office figures which used current land value figures were not as realistic as the Senate committee's.

"Our recommendation of 80 per cent of total cost of production will not assure grain farmers of a break-even position should supplies be grossly in excess of demand, but neither will it encourage producers to grossly over-produce since they will know government will not bail them out." Hirth said. "These levels should remove the likelihood of outright bankruptcy, encourage greater efficiency in production, represent sufficient encouragement for grain farmers to produce sufficient supplies for projected market demand, and lessen the need for government intervention."

Hirth told the Committee UEP favors the 35-year average of acquisition cost of land because it will have less influence on the escalation of land values. To use a formula for the cost of production which reflects the immediate land sale values would only add to the inflationary pressures to escalate those values, he said.

"We believe the below-production cost target price levels we recommend will also reduce the need for federally held commodity reserves which later will be used to depress grain prices and encourage over-production in the livestock and poultry industries," the U.E.P. spokesman con-

tinued. He told the Committee that UEP would support an extension of time for commodity loans beyond the current one-year period in order to give producers an opportunity to move his product into the market in another marketing year. He said this, too, would minimize government involvement in federally held grain reserves while assuring producers of a cushion against a severe market drop in any crop year.

In concluding his testimony before the House Agriculture Committee, Hirth asked that language be included under both Title I and Title II of the Food For Peace Programs (P.L. 480) "which would encourage utilization of processed agricultural products" in the export programs.

"The egg industry believes it can help meet the world's need for high protein foods with such products as dried egg mix and canned fowl meat," Hirth stated. "We believe both of these products would be excellent relief commodities for the hungry around the world. Our members feel that PL 480 and other export programs should also emphasize products that represent agriculture and labor via the finished or processed state."

Hirth pointed to the outstanding history that egg mix and canned fowl has within the U.S. as part of the USDA commodity programs. They can be packaged in small or large units and all a person needs for preparing a meal is water, fire and some type of utensil for cooking, he added.

From UEP's United Voices

PUZZLED?

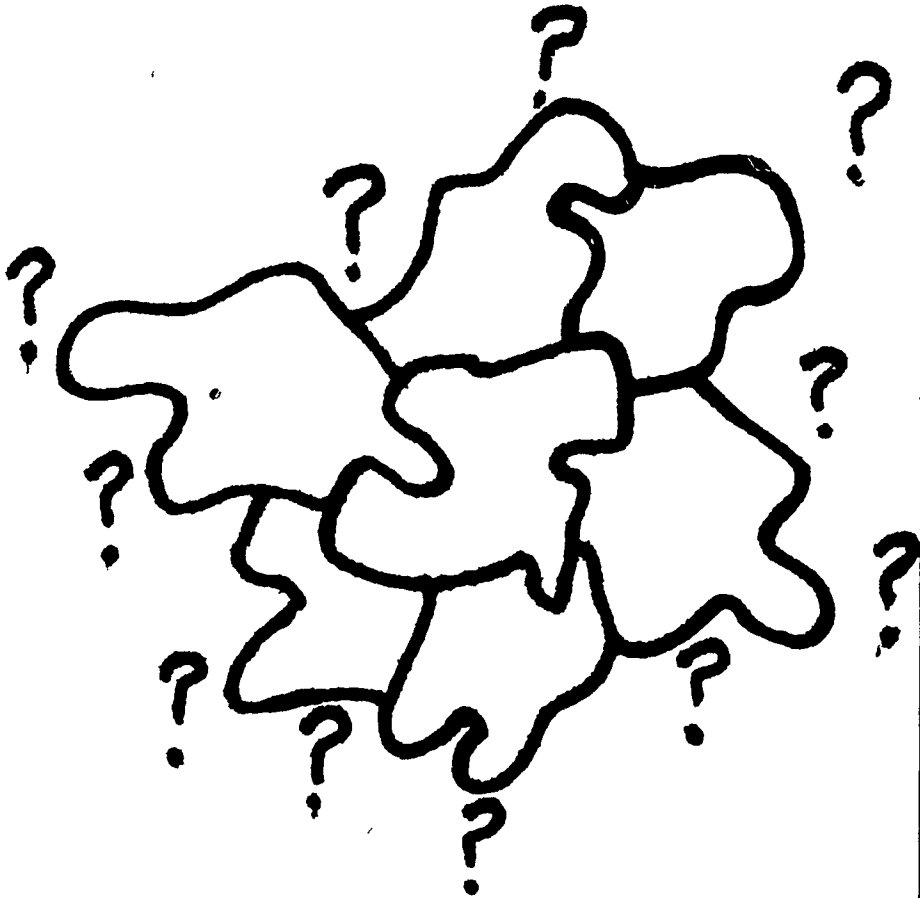

Feed Companies all across the U.S. are puzzled at the rate their customers are switching to VIGORTONE FEEDS!! They are even more puzzled at how hard it is to get even one of them to switch back!!

To find out some of the reasons why, contact your local VIGORTONE PRE-MIXES serviceman soon!! You will find him to have 100 PER CENT INTEREST in your livestock needs, and your increased profits!

Over 150 Servicemen in Penna. alone!

*Better rations cost less . . .
with Vigortone.*

VIGORTONE

PRE-MIXES Especially Now!

50 warehouses—over 5400 servicemen
3 manufacturing plants

LEON B. HERSHEY
Box 166 Paradise, PA
717-442-4807

RON L. HERSHEY
R2 Gap, PA
717-442-8573

JASON E. MILLER
R4 Lancaster, PA
717-393-7244

WM. J. YODER
R1, Conestoga, PA
717-872-8047

ELI KING
R1 Box 59 Ronks, PA
717-768-3608
Berks Co., PA

ALVIN ESH
Box 72 Intercourse, PA
717-768-3128

H. MELVIN CHARLES
R1 Washington Boro, PA
717-684-5783

PETE CALDWELL
R1 Windsor, PA
717-246-1046

RALPH E. BRUNGART
Loganton, PA
717-725-2355

ELAM G. HOOVER
R1 New Holland, PA
717-354-0432

PHILIP A. HAYES
Oxford RD2
215-932-8736

CHRISTIAN L. STOLTZFUS
R2 Box 409 Elverson, PA
215 286-5995

CHESTER SOLTYS, JR.
Spring City, PA
215-948-3647
ERIC W. FOGG
West Chester, PA
215-696-2283

JAMES STUTZMAN SONS
R3 Kutztown, PA
215-683-7198

ELWIN REAM
Hughesville, PA
717-584-4085

SHERWOOD A. WITMER
Box 138 Berrysburg, PA
717-362-8823

PAUL L. KREIDER
R2 Palmyra, PA
717-964-3791

WILMER J. WEAVER
R1 Fredericksburg, PA
717-865-6710

MARLIN GEESAMAN
R2 New Port, PA
717-582-4598

RUSSELL FRY
Duncannon, PA

ROMAN YODER
R1 Grantsville, MD
301-895-5302

KAREN TAYLOR
R3 Cambridge, MD
301-228-3989

ED FOGG
Malvern, PA
215-647 6818

C. OWEN FRANKLIN
R3 Bridgeton, NJ
609 451-5919

JOHN KLEMUX
Box 638 Hammonton, NJ
609-561-0982

RAYMOND CANTI
RD2 Phillipsburg, NJ
201-859-1314



If you have fat
cattle or
need feeders . . .

**THINK
NEW HOLLAND**

BEEF SALES

MONDAY 1:30 P.M.

THURSDAY 11:00 A.M.

Sale Order - Fat Bulls, Steers, Stockers, Beef
Cows and Veal Calves.

NEW HOLLAND SALES STABLES, INC.

Phone 717-354-4341

Daily Market Report Phone 717-354-7288

Abe Diffenbach, Manager

Field Representatives - Bob Kling 717-354-5023
Luke Eberly 215-267-6608

**TRY A
CLASSIFIED
AD!**

**BIG TRUCK
HAULING
WITH YOUR
PICKUP
AND THE...**

**WINNEBAGO
Agri-Trailer™**



Two-speed landing
gear provides
easy hitching.

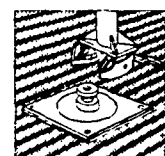

Easy hook-up with
wide-opening jaws
of Pin & Plate.

Hitch this versatile trailer to your truck for
road travel, switch it to your tractor for field
loading. The Winnebago Agri-Trailer can carry
as much as a 3-ton truck. It can haul over 7½
tons. Or 285 bushels of grain.

Winnebago's 5th
wheel design gives
unique stability. It
turns short, backs up
easy, and trails true
at highway speeds
without fishtailing.

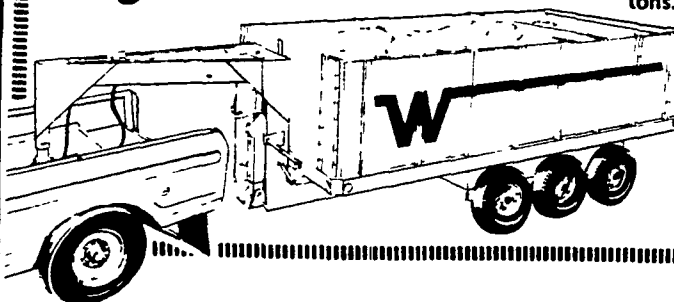

Kauffman's Agri-Trailer Sales

Elizabethtown

Box 655 RD 1

717-367-3550

Pennsylvania